



Land Rover  
Optional Equipment  
Parts Catalogue

Part No. RTC 9009

June 1973



LAND-ROVER SERIES IIA AND III  
OPTIONAL EQUIPMENT PARTS CATALOGUE  
BONNETED CONTROL MODELS

First Issue - June 1973

Rover British Leyland  
UK Limited



Service Department  
Solihull, Warwickshire  
Telephone: 021 743 4242  
Telegrams: Rovrepair Solihull  
Telex: 338641

Parts Department  
P O Box 79  
Cardiff  
Great Britain  
Telephone: Cardiff 33681  
Telegrams: Rovparts, Cardiff  
Telex: 49-359

Please note that all prices and specifications  
are subject to alteration without notice

Always quote type and number of vehicle  
when ordering

By Appointment to  
Her Majesty  
Queen Elizabeth II



Manufacturers  
of Motor Cars and  
Land-Rovers

By Appointment to  
Her Majesty  
Queen Elizabeth  
the Queen Mother



Suppliers  
of  
Motor Cars and  
Land-Rovers

GROSS INDEX. INDEKS. GRUPPER. INHOUD-HOOFDSTUKKEN. RYHMAHAKEMISTO. TABLE DES SECTIONS.  
GRUPPENVERZEICHNIS. INDICE DEI GRUPPI. NUMBERACAO DE GRUPO. INDICE DEL GRUPO. GRUPINDEX.

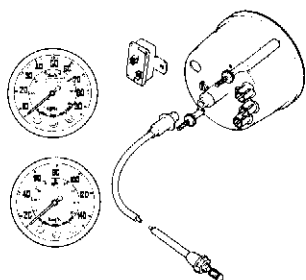
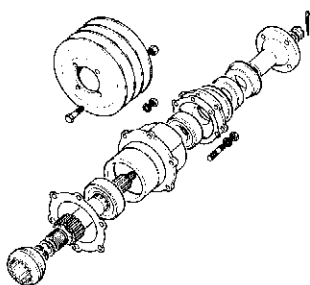
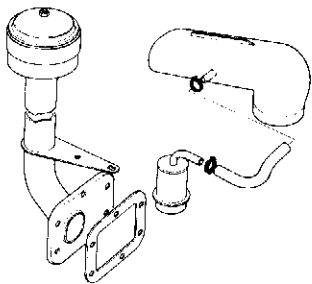

25 01  
to  
26 65

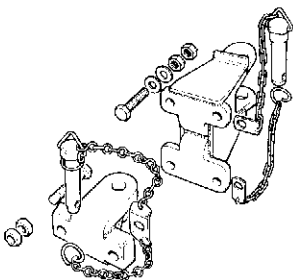
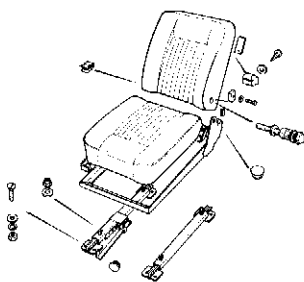

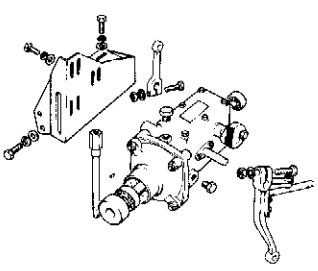
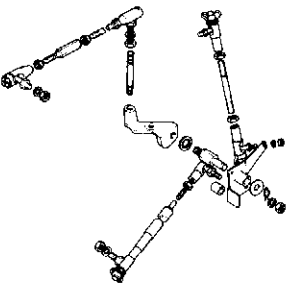
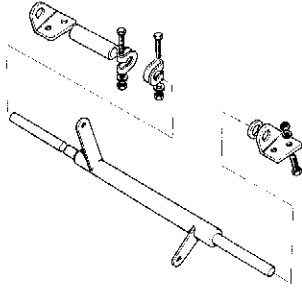
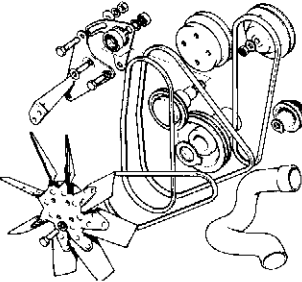
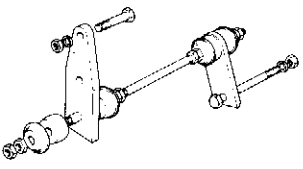
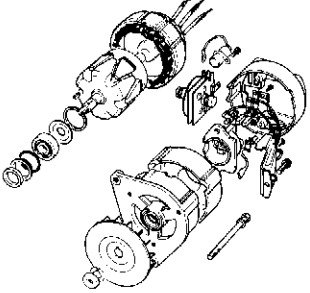
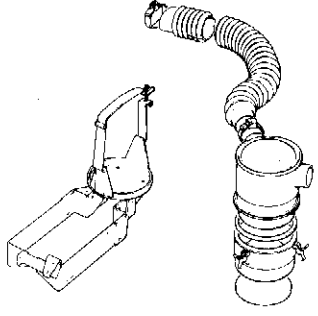
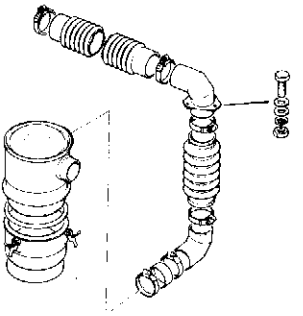
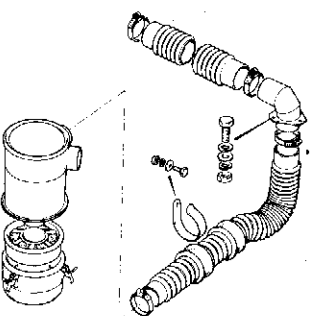
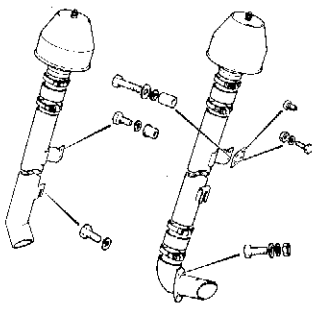
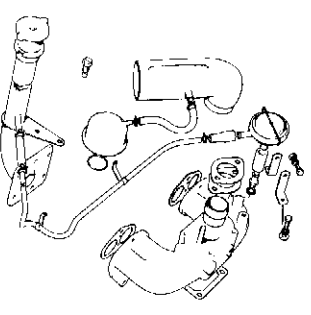
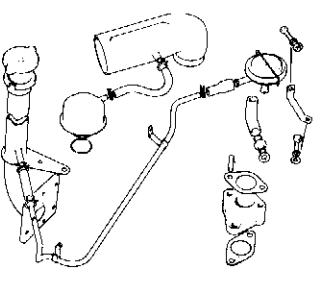
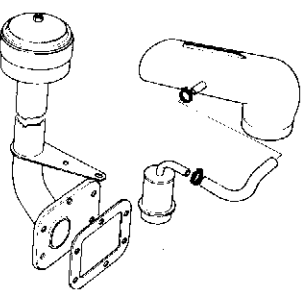
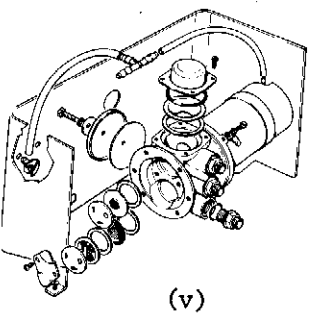
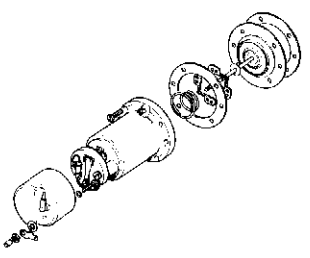
 <p>25 01</p>	 <p>25 02</p>	 <p>25 03</p>
 <p>25 04</p>	 <p>25 05</p>	 <p>25 06</p>
 <p>Series IIA 2 1/4 Petrol 25 10</p>	 <p>Series III 2 1/4 Models 25 11</p>	 <p>Series III 2.6 Models 25 12</p>
 <p>25 13</p>	 <p>Series IIA 25 14</p>	 <p>Series III 25 15</p>
 <p>25 16</p>	 <p>25 17 (v)</p>	 <p>25 18</p>

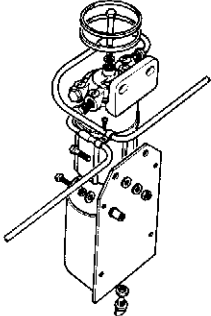
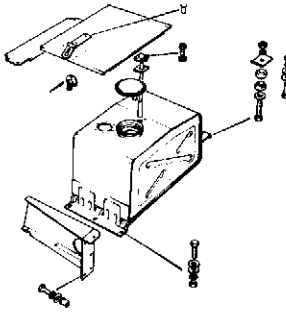
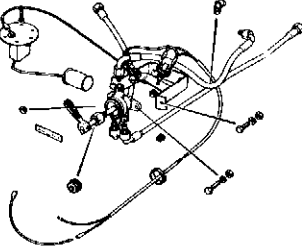
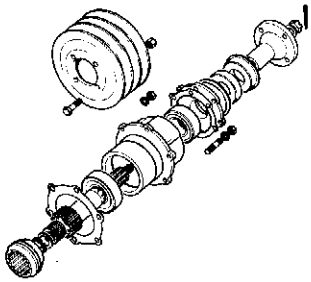
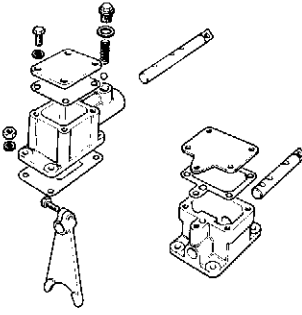
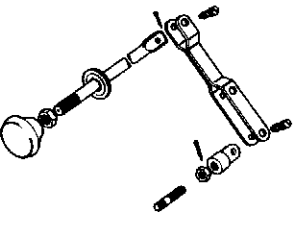
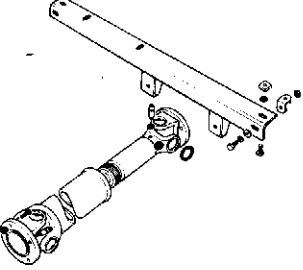
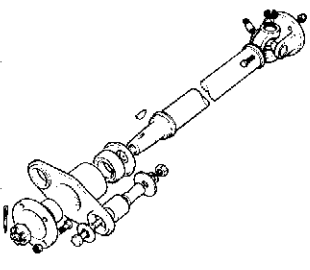
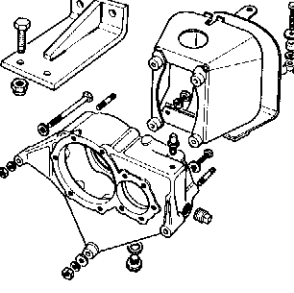
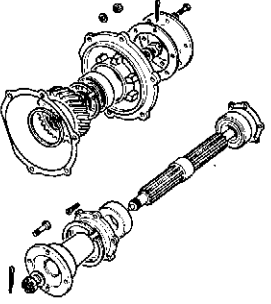
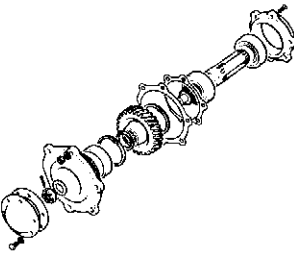
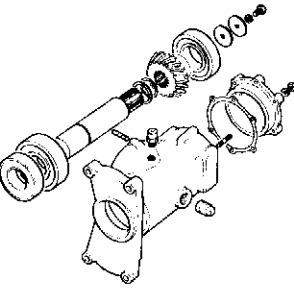
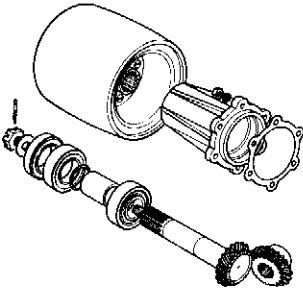
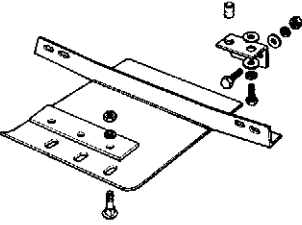
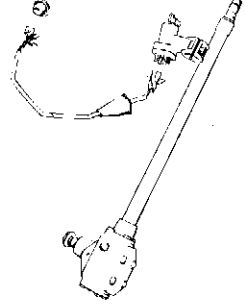
		
		
		
		
	 <p>(vi)</p>	

25 19

25 22

25 23

25 25

25 26

25 27

25 28

25 29

25 30

25 31

25 32

25 33

25 34

25 35

25 38

PAGE INDEX. INDEKS SIDER. INHOUD-BLADZIJDEN. SIVUHAKEMISTO. INDEX. SEITENVERZEICHNIS.  
 INDICE DELLE PAGINE. NUMERAÇÃO DE PAGINA. INDICE DE LA PAGINA SIDOINDEX

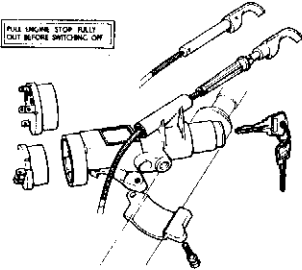
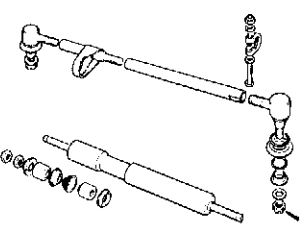
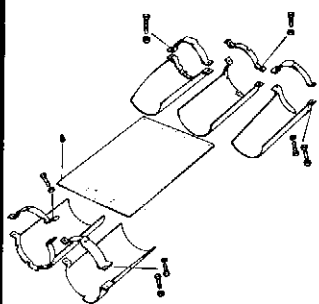
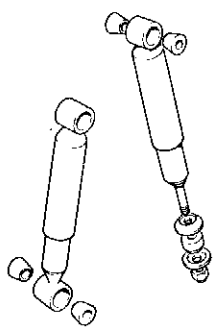
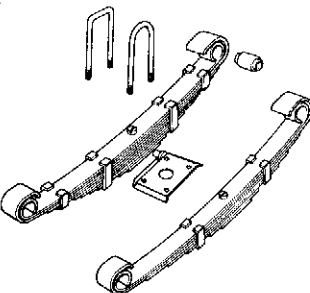
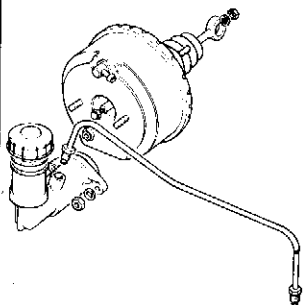
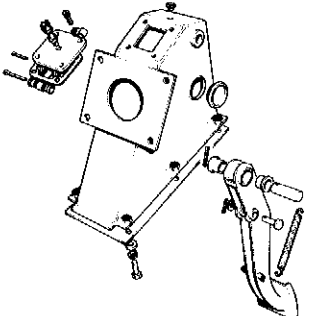
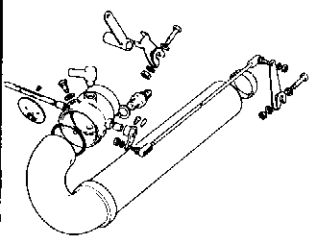
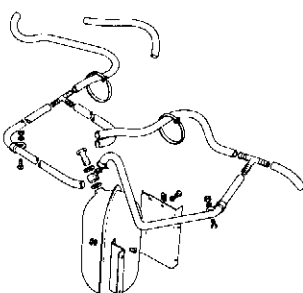
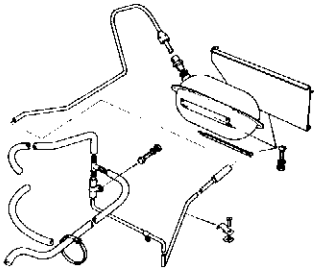
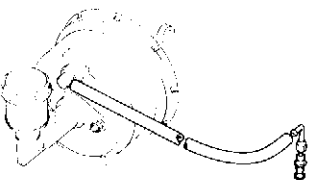
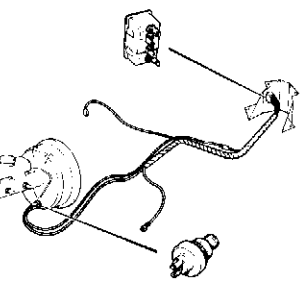
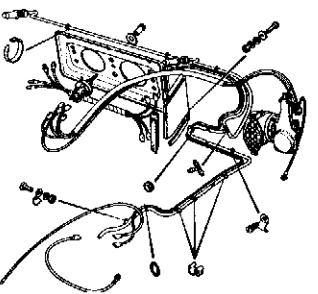
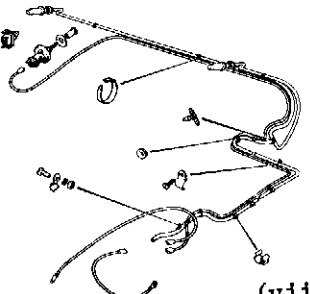
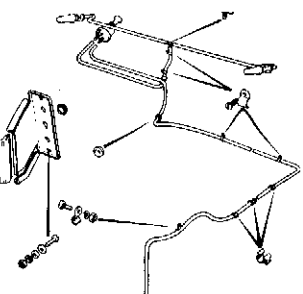
 <p>25 39</p>	 <p>25 40</p>	 <p>25 42</p>
 <p>25 44</p>	 <p>25 45</p>	 <p>25 48</p>
 <p>25 49</p>	 <p>25 50</p>	 <p>25 51</p>
 <p>25 52</p>	 <p>25 53</p>	 <p>25 54</p>
 <p>25 57</p>	 <p>25 58 (vii)</p>	 <p>25 59</p>

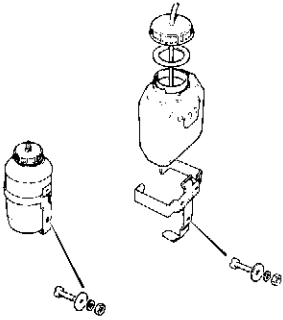
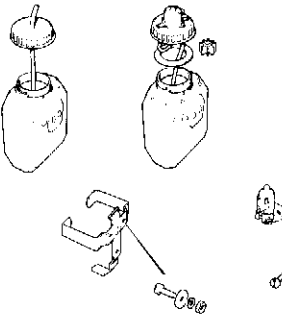
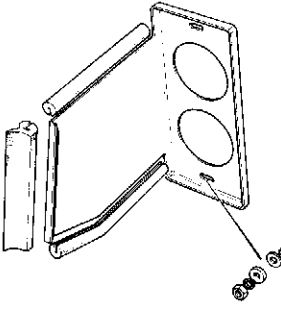
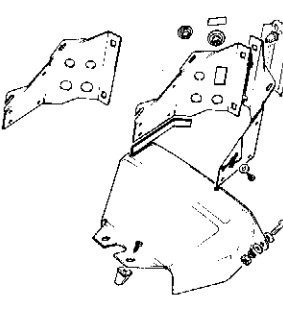
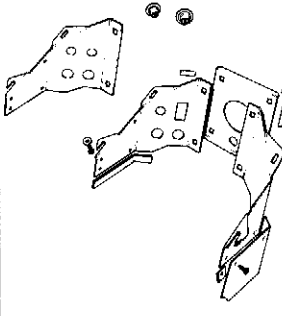
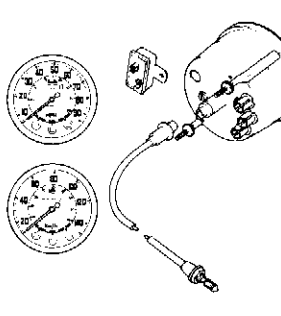
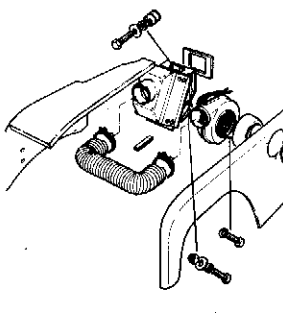
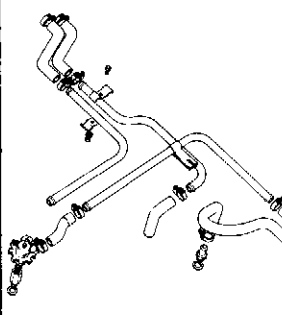
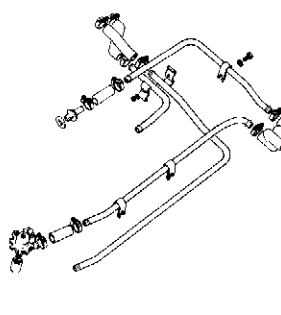
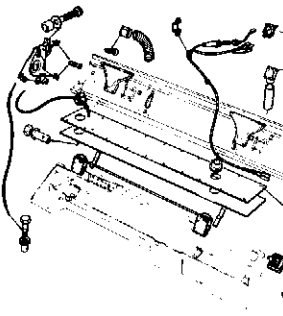
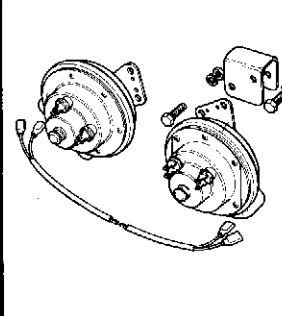
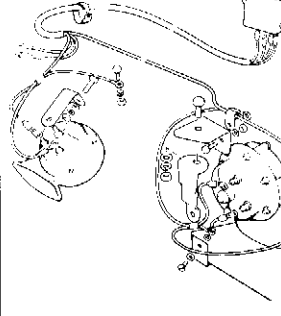
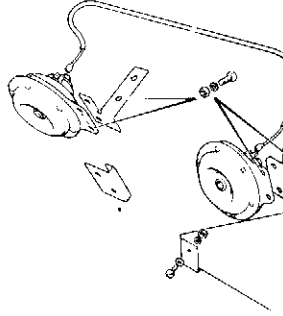
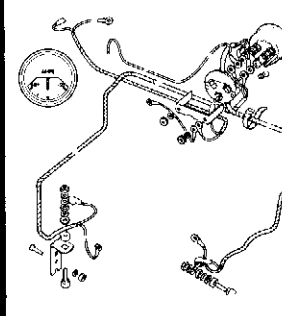
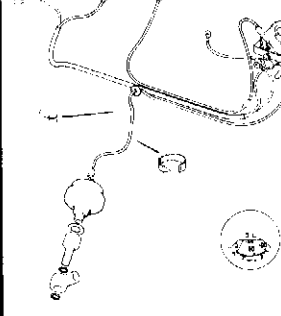
 <p>25 60</p>	 <p>25 61</p>	 <p>25 65</p>
 <p>25 66</p>	 <p>25 67</p>	 <p>25 69</p>
 <p>25 70</p>	 <p>2½ Models 25 71</p>	 <p>2.6 Models 25 72</p>
 <p>25 73</p>	 <p>25 77</p>	 <p>25 78</p>
 <p>25 79</p>	 <p>25 81 (viii)</p>	 <p>25 82</p>

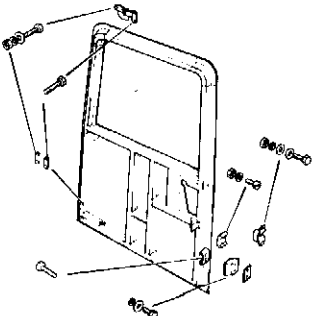
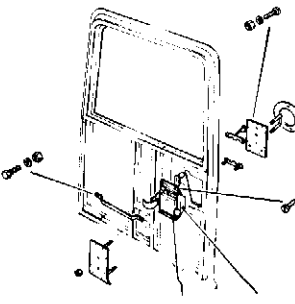
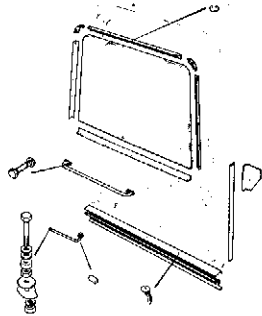
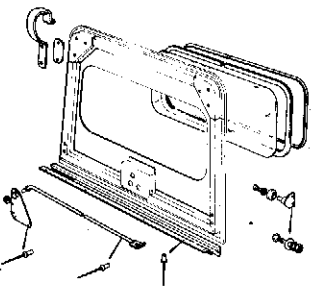
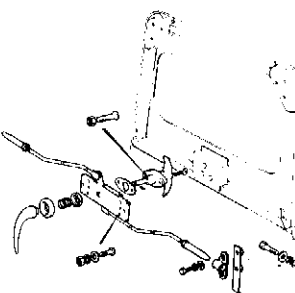
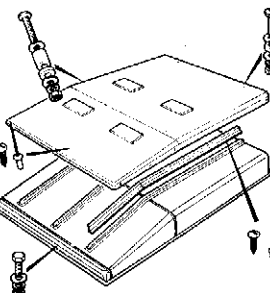
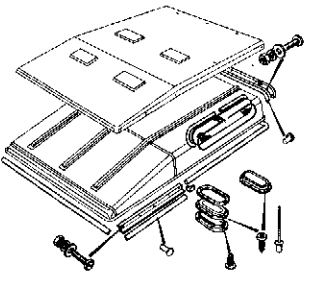
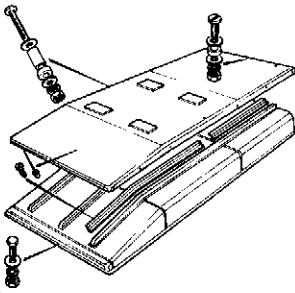
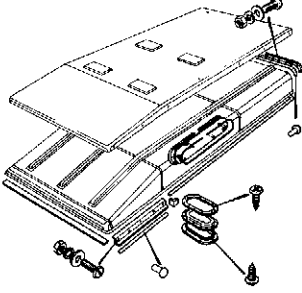
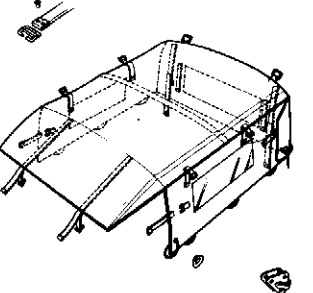
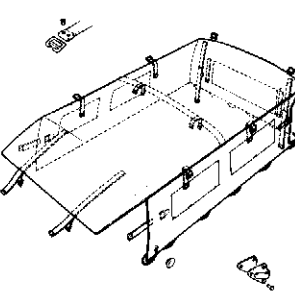
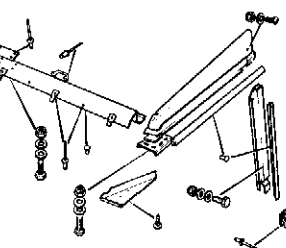
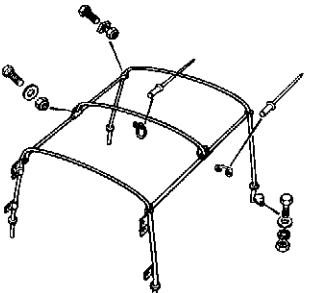
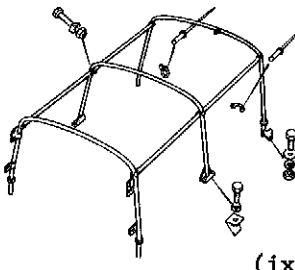
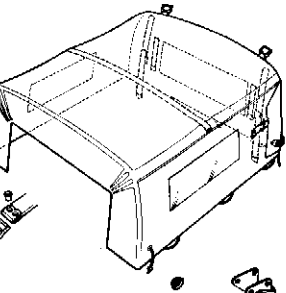
 <p>26 01</p>	 <p>26 02</p>	 <p>26 03</p>
 <p>26 04</p>	 <p>26 05</p>	 <p>88 in. 26 06</p>
 <p>88 in. 26 07</p>	 <p>109 in. 26 08</p>	 <p>109 in. 26 09</p>
 <p>88 in. 26 10</p>	 <p>109 in. 26 11</p>	 <p>26 12</p>
 <p>88 in. 26 13</p>	 <p>109 in. 26 14 (ix)</p>	 <p>88 in. 26 15</p>

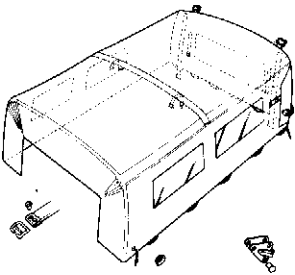
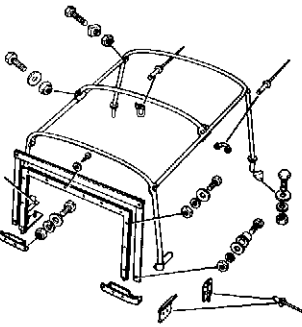
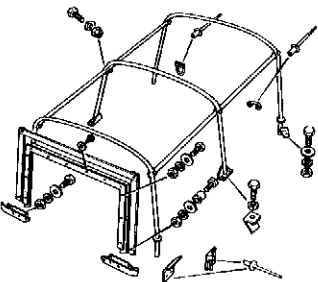
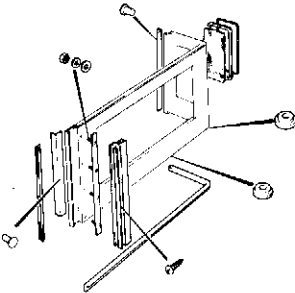
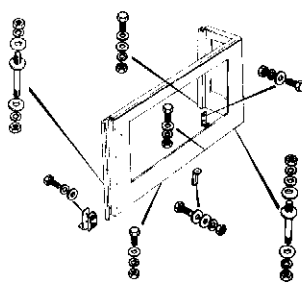
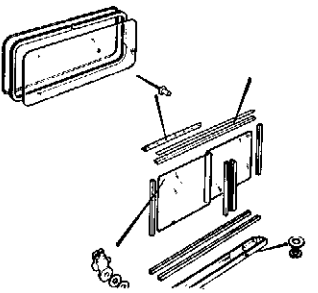
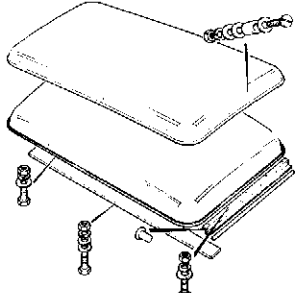
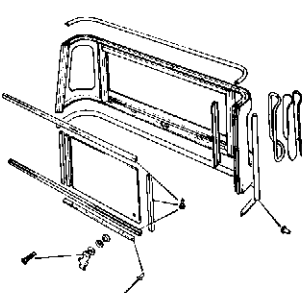
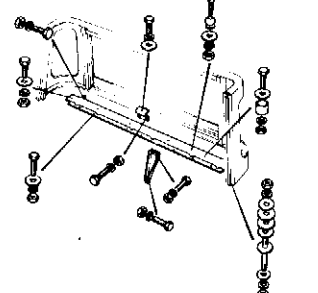
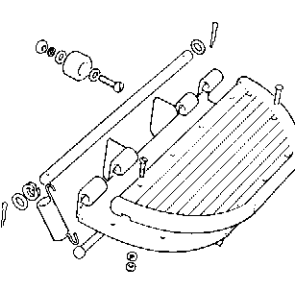
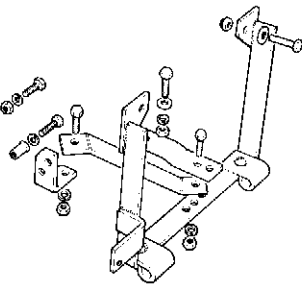
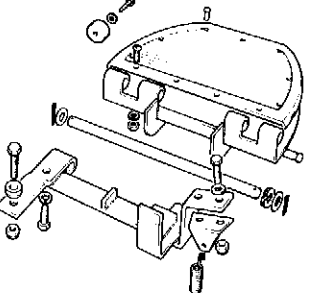
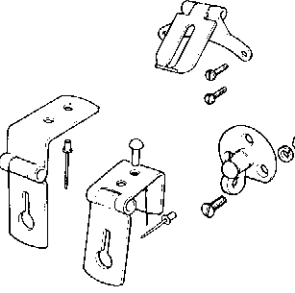
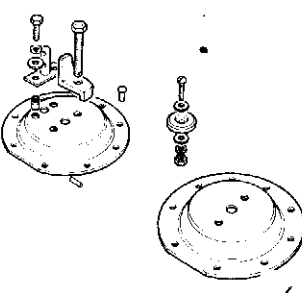
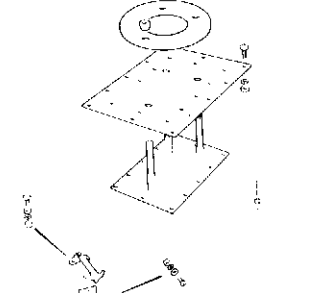

 <p>109 in. 26 16</p>	 <p>88 in. 26 17</p>	 <p>109 in. 26 18</p>
 <p>26 19</p>	 <p>26 20</p>	 <p>26 21</p>
 <p>26 22</p>	 <p>26 23</p>	 <p>26 24</p>
 <p>26 27</p>	 <p>26 28</p>	 <p>26 29</p>
 <p>26 30</p>	 <p>26 31 (x)</p>	 <p>26 32</p>

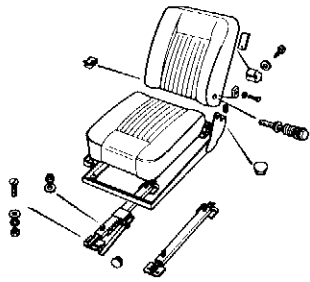
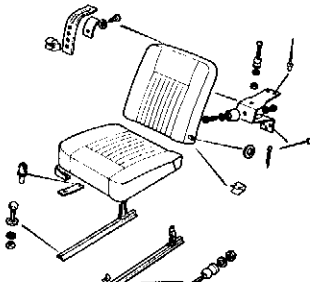
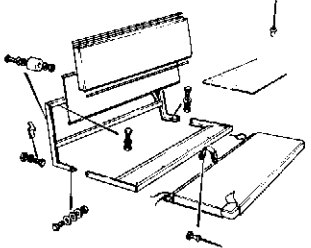
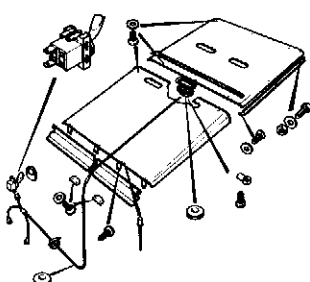
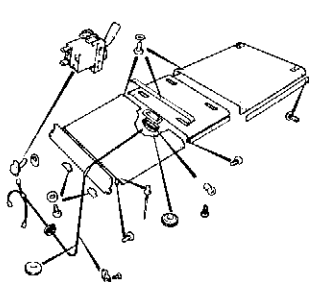
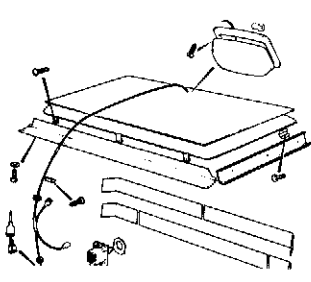
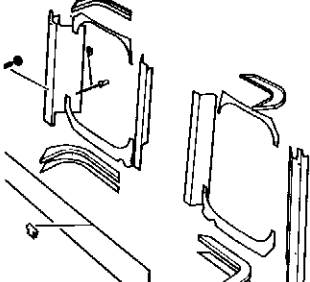
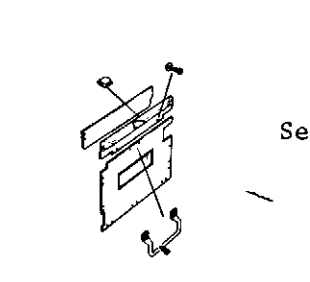
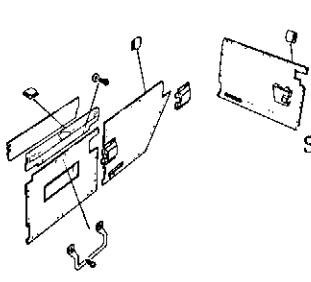
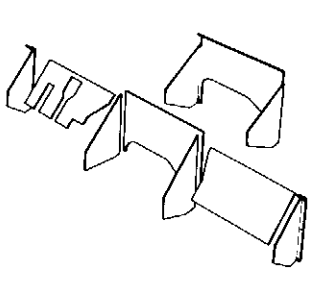
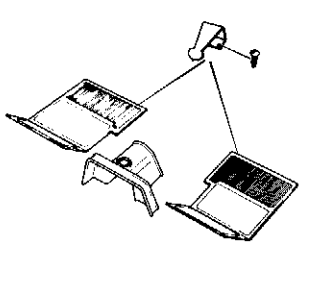
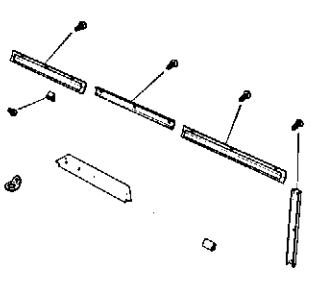
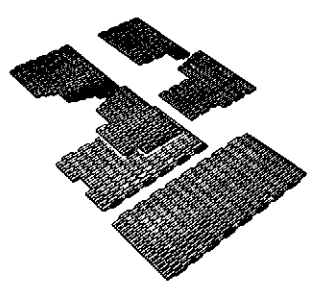
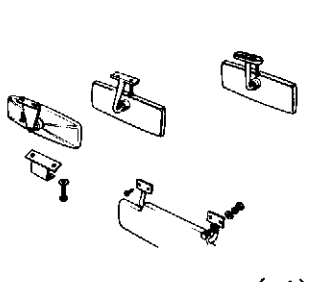
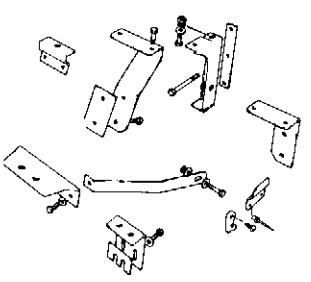
 <p>26 33</p>	 <p>26 34</p>	
 <p>26 37</p>	 <p>26 38</p>	 <p>26 39</p>
 <p>26 40</p>	 <p>Series IIA 26 41</p>	 <p>Series II 26 42</p>
 <p>26 43</p>	 <p>26 44</p>	 <p>26 45</p>
 <p>26 48</p>	 <p>26 49</p> <p>(xi)</p>	 <p>26 51</p>

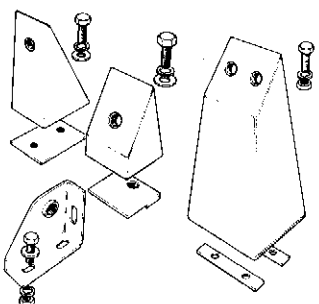
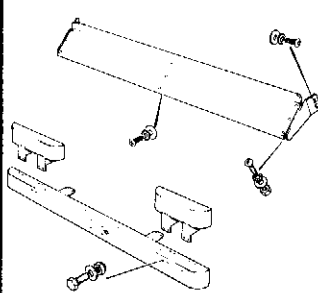
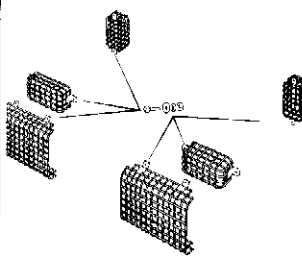
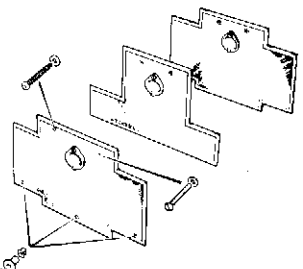
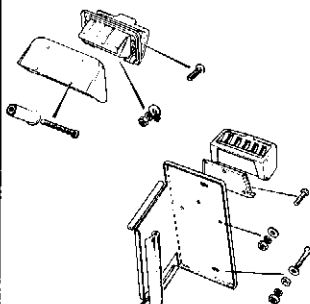
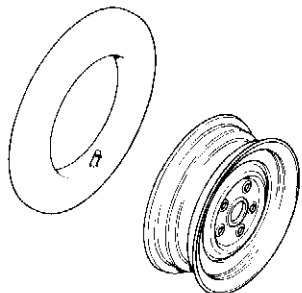
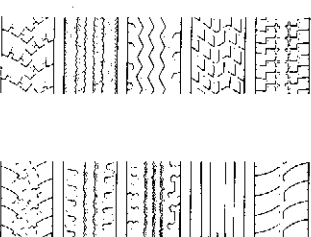
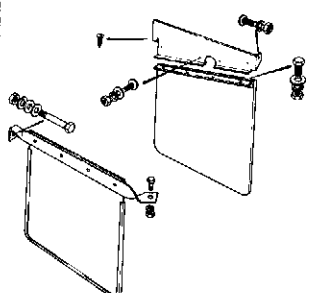
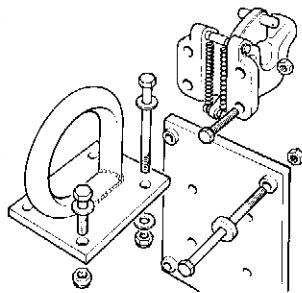
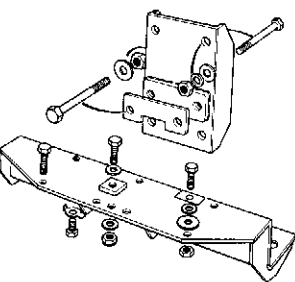
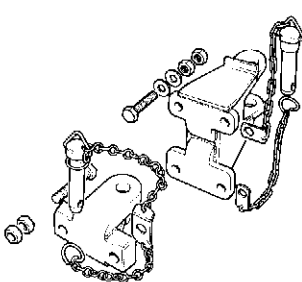
 <p>26 52</p>	 <p>26 54</p>	 <p>26 55</p>
 <p>26 56</p>	 <p>26 57</p>	 <p>26 59 -</p>
 <p>26 60</p>	 <p>26 61</p>	 <p>26 63</p>
 <p>26 64</p>	 <p>26 65</p>	

GOVERNOR, MOUNTING BRACKET AND FIXINGS .SERIES IIA AND III.

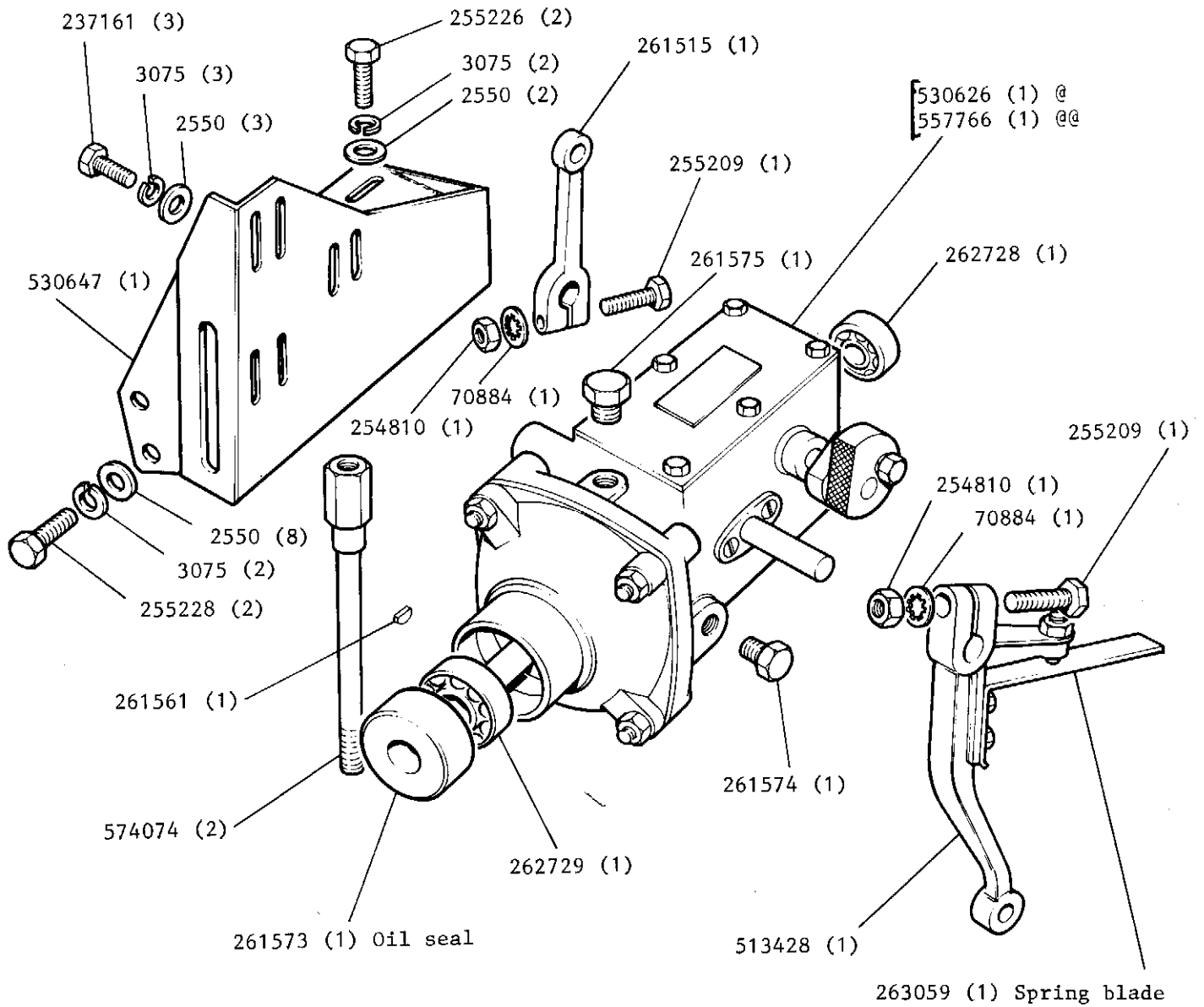

REMARKS

@ Up to engine suffix H inclusive

@@ From engine suffix J onwards and Series III

GOVERNOR CONTROL LEVERS AND FIXINGS, SERIES IIA AND III

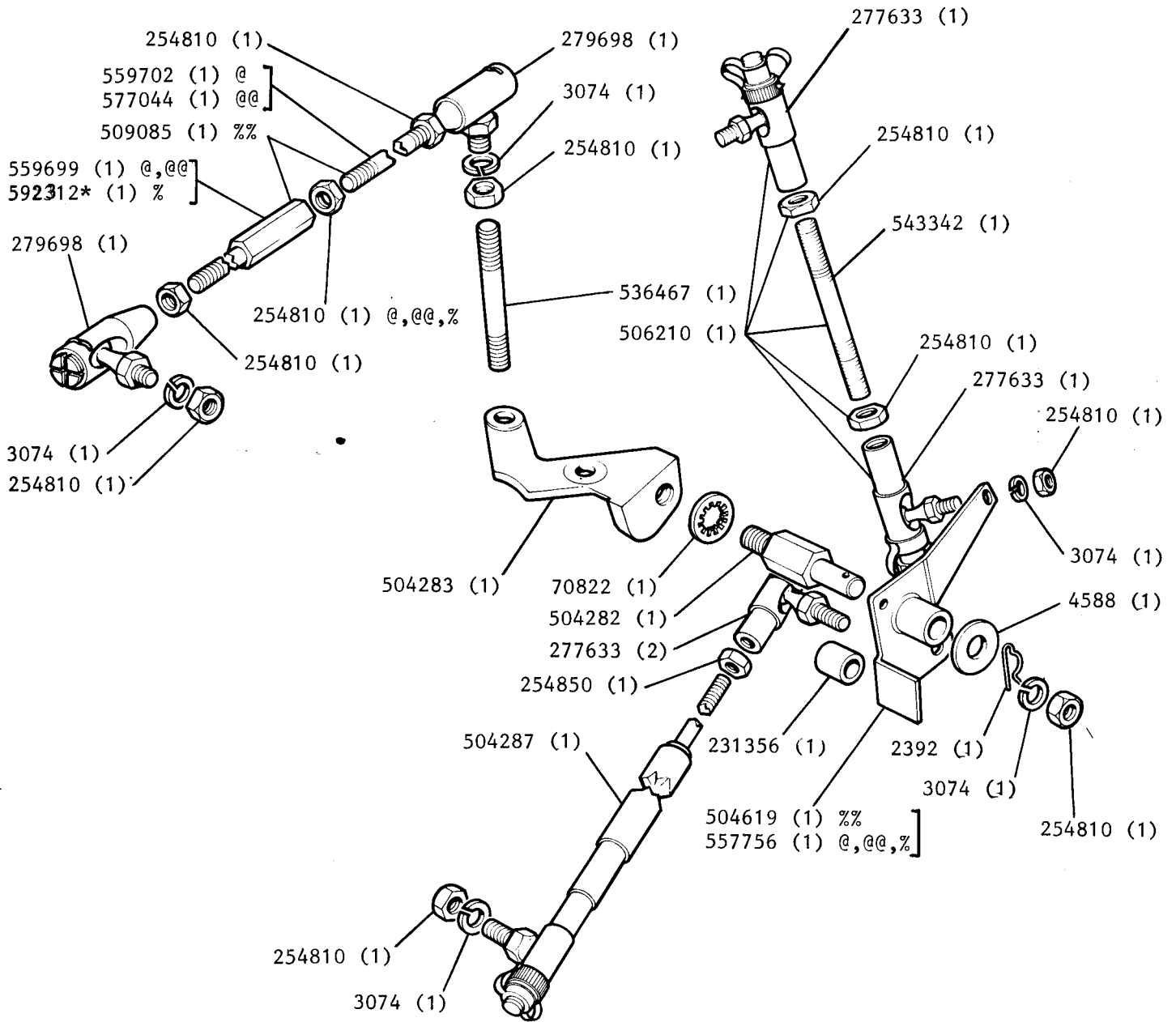

REMARKS

- @ Series IIA from engine suffix J up to 30th September 1968
- @@ Series IIA from 1st October 1968 onwards
- % Series III
- %% Series IIA up to engine suffix H inclusive

RELAY TUBE AND LEVER, BRACKETS AND FIXINGS SERIES IIA AND III

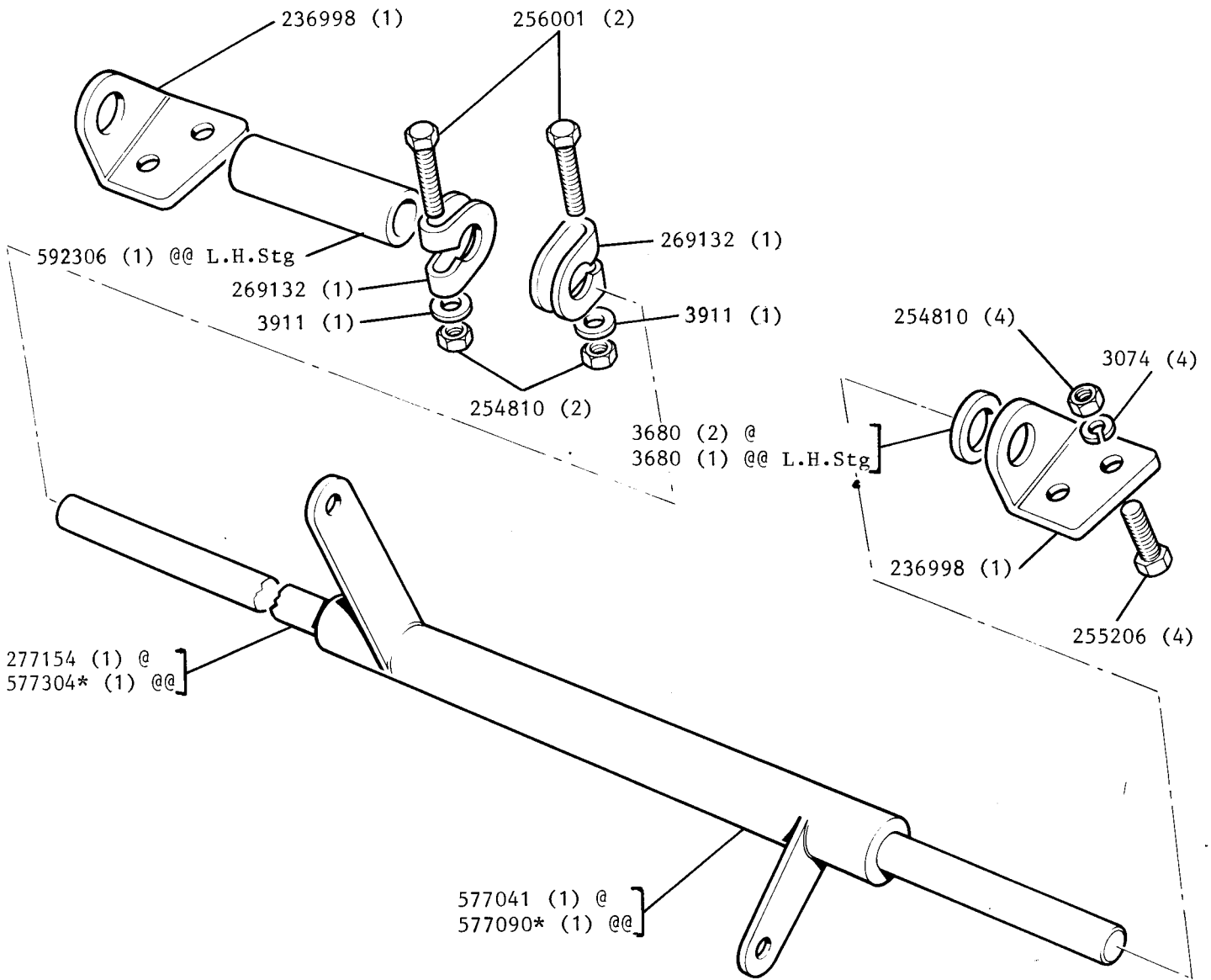

REMARKS

@ Series IIA from 1st October 1968 onwards

@@ Series III

FAN, PULLIES AND DRIVE BELTS FOR ENGINE GOVERNOR SERIES IIA AND III

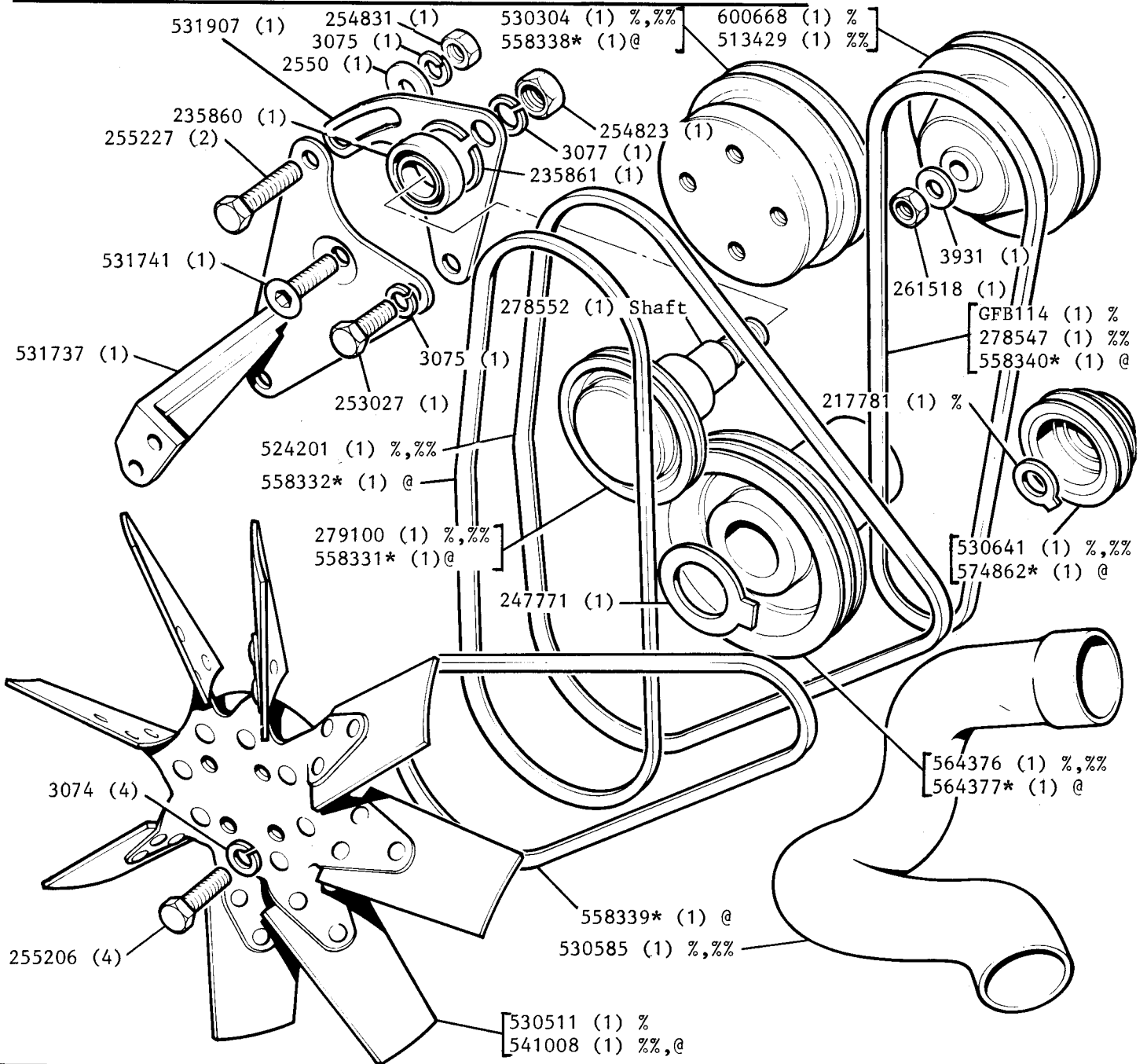

REMARKS

- @ Series III
- % Series IIA up to engine suffix H inclusive
- %% Series IIA from engine suffix J onwards

TIE ROD FOR ENGINE SERIES IIA AND III

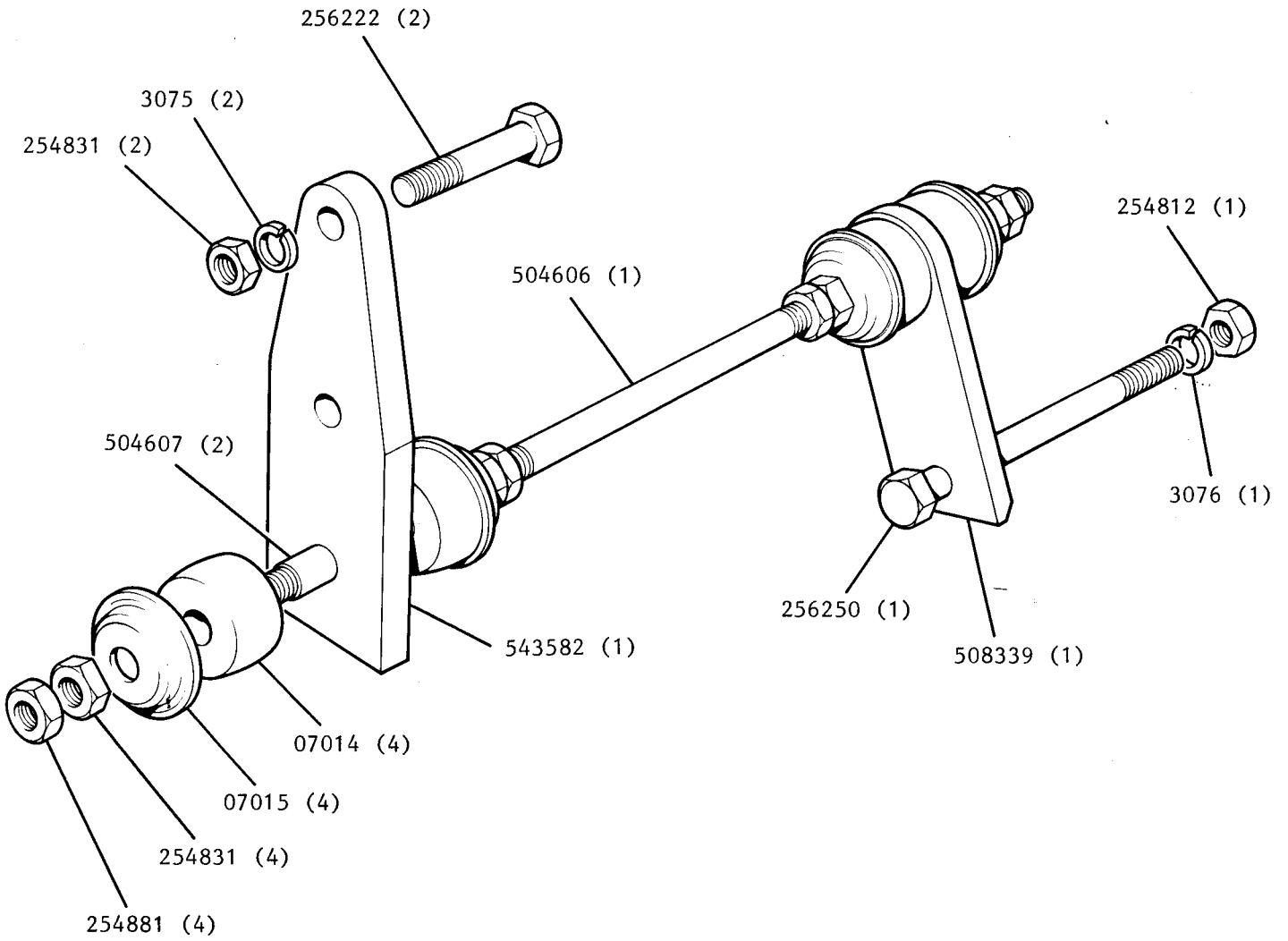

REMARKS



ALTERNATOR 18 ACR BATTERY SENSED SERIES III

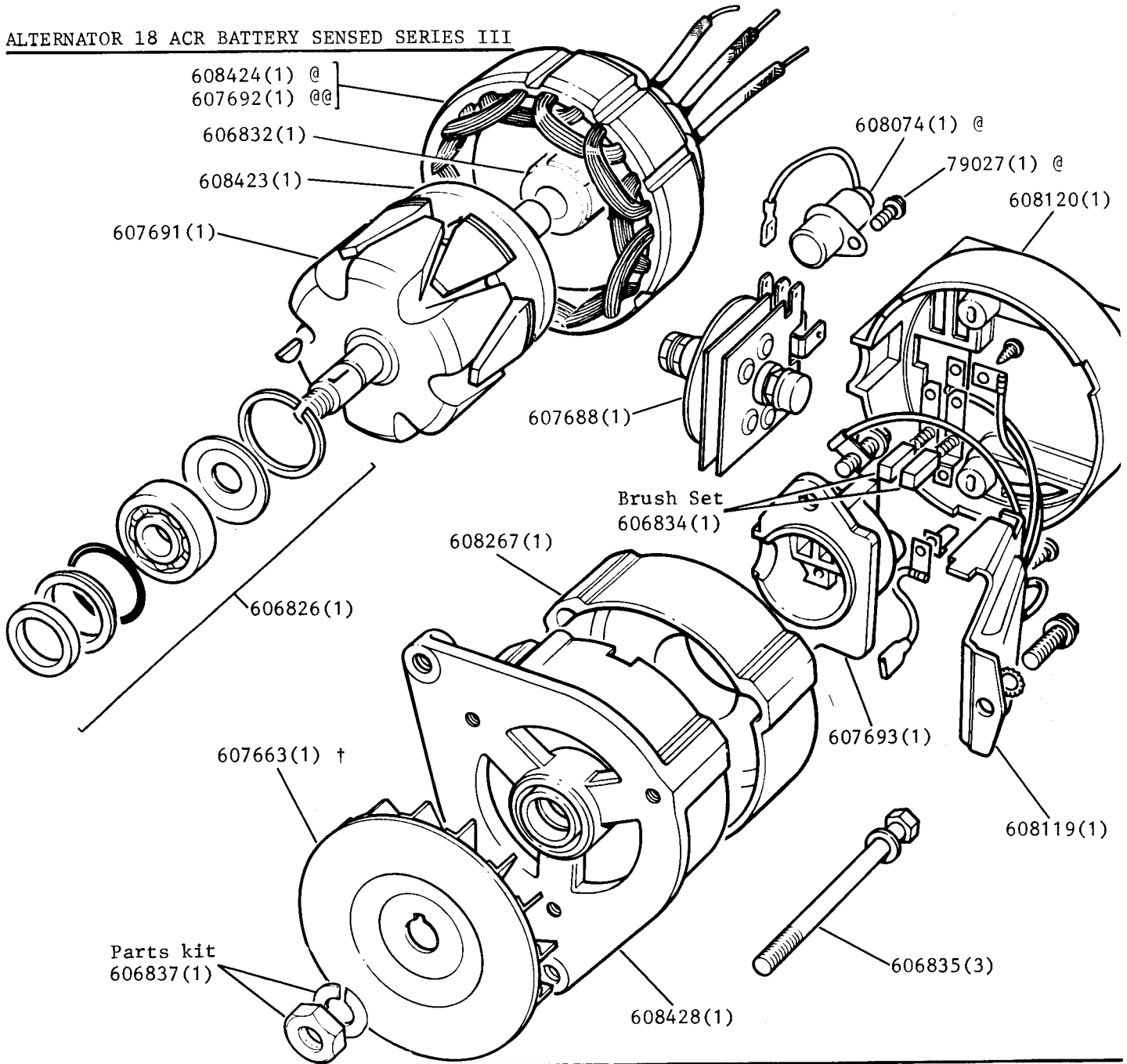

REMARKS

Surge Protection Device 608425(1)

@ Part of Alternator Assembly 608427

@@ Part of Alternator Assemblies 589065 and 608305

† Part of Alternator Assembly 589065, not part of Alternator Assemblies 608305 and 608427

Alternator 18 ACR kit 607608(1) 2½ petrol	] Comprises of the following
Alternator 18 ACR kit 607609(1) 2.6 petrol	
Alternator 18 ACR kit 607610(1) 2½ diesel	
Alternator 18 ACR 589065(1) Lucas 23684	] Alternatives
Alternator 18 ACR 608305(1) Lucas 23697	
Alternator 18 ACR 608427(1) Lucas 23739	

Cable assembly 589067(1) 2½ petrol	] For vehicles with an automatically operated choke warning light	
Cable assembly 589069(1) 2.6 petrol		
Cable assembly 589859(1) 2½ petrol		] For vehicles with a manually operated choke warning light
Cable assembly 589860(1) 2.6 petrol		
Cable assembly 589068(1) 2½ diesel		

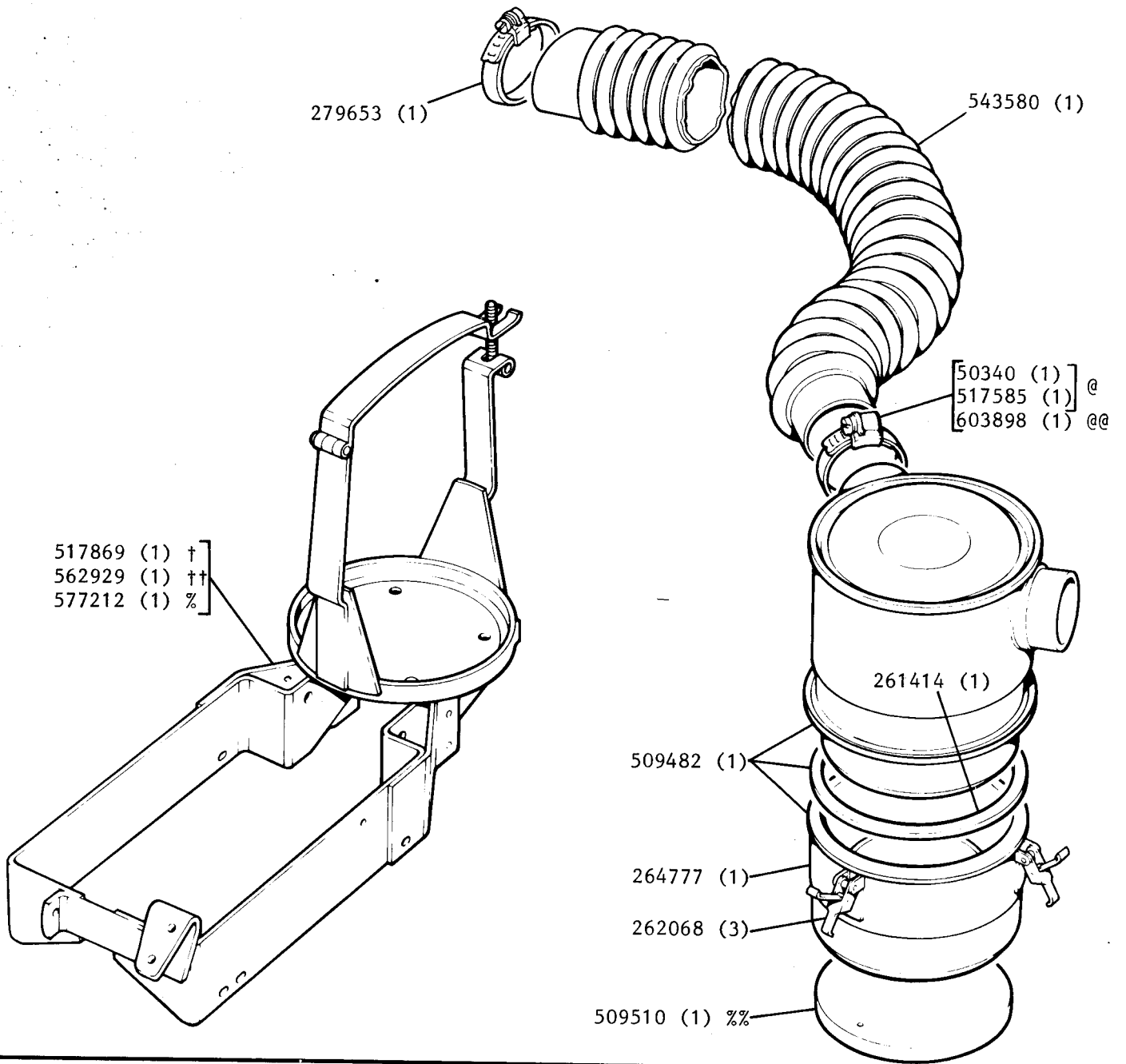

REMARKS

- @ Alternatives. Up to December 1968
  - @@ From January 1969 onwards
  - † Up to vehicle serial number 26409160C and 24429283C
  - †† From vehicle serial number 26409161C and 24429284C to July 1969
  - % From August 1969 onwards
  - %% Up to July 1969
- For raised air intake kit part numbers see frame 25 13

RAISED AIR INTAKE AIR CLEANER, ELBOW AND HOSES.

SERIES III 2 1/4 PETROL AND DIESEL

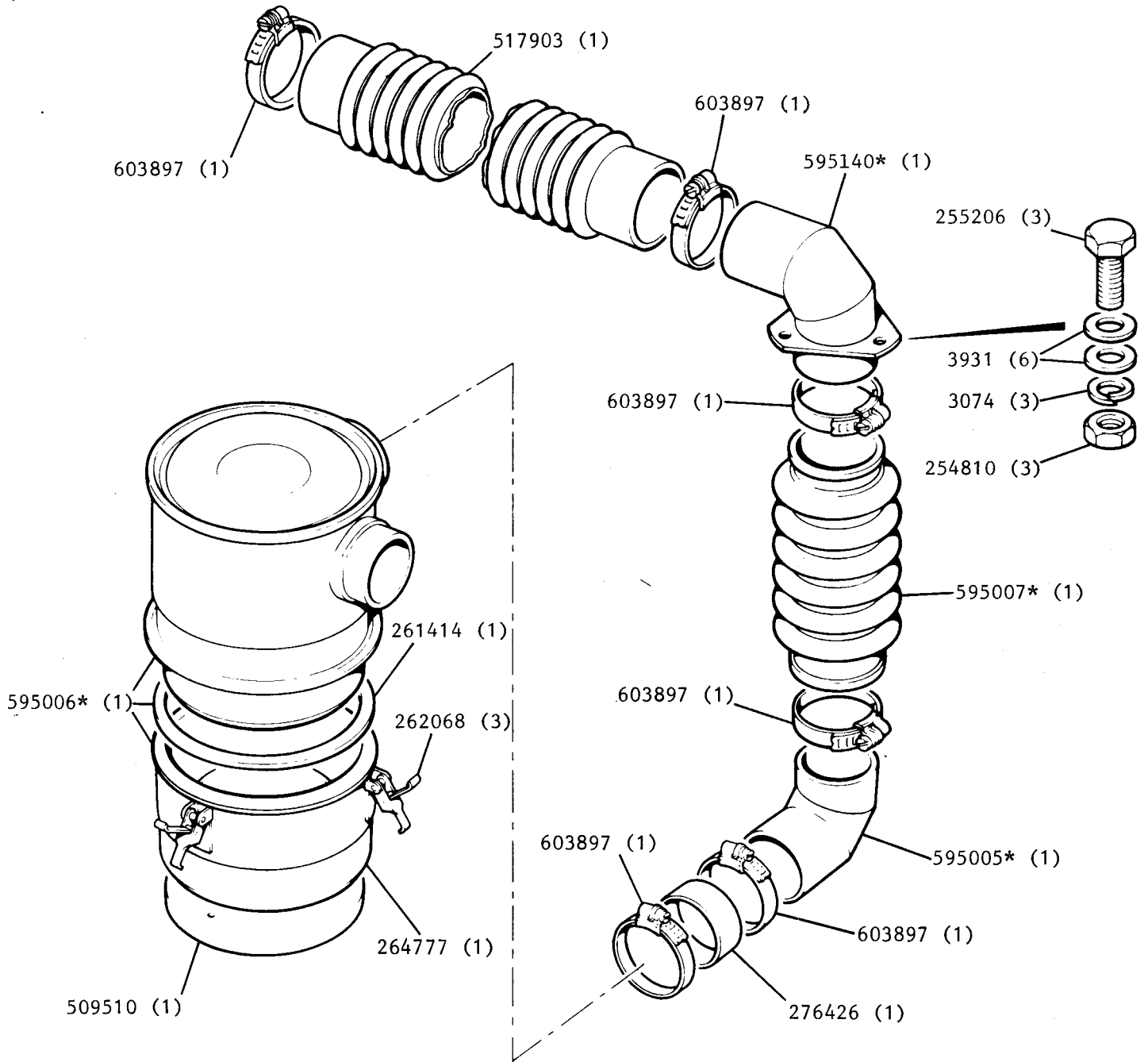

REMARKS

For raised air intake kit part numbers see frame 25 13

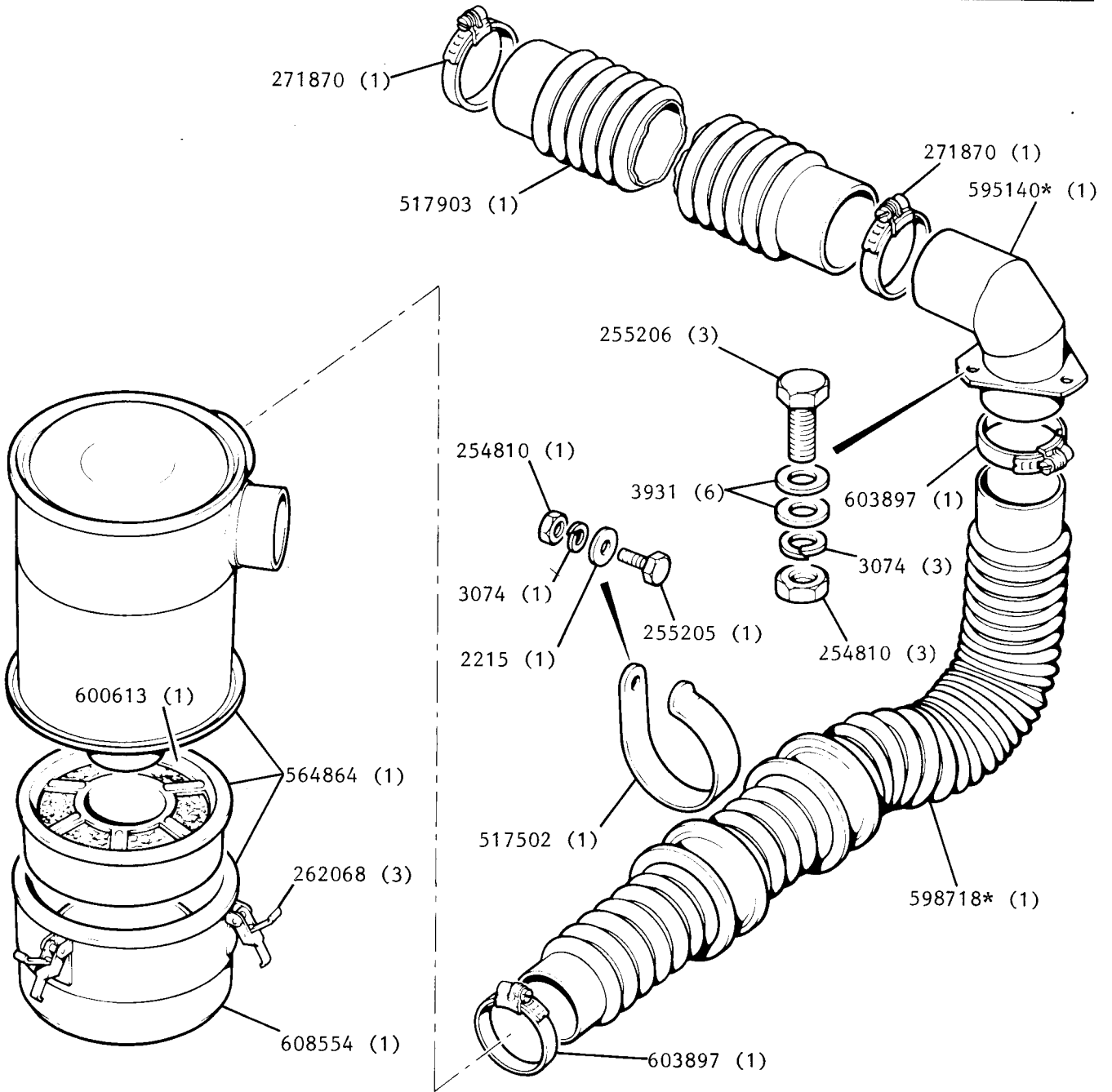

REMARKS

For raised air intake kit part numbers see frame 25 13

RAISED AIR INTAKE PIPE AND CENTRIFUGAL AIR CLEANER

SERIES IIA 2½ PETROL AND SERIES III

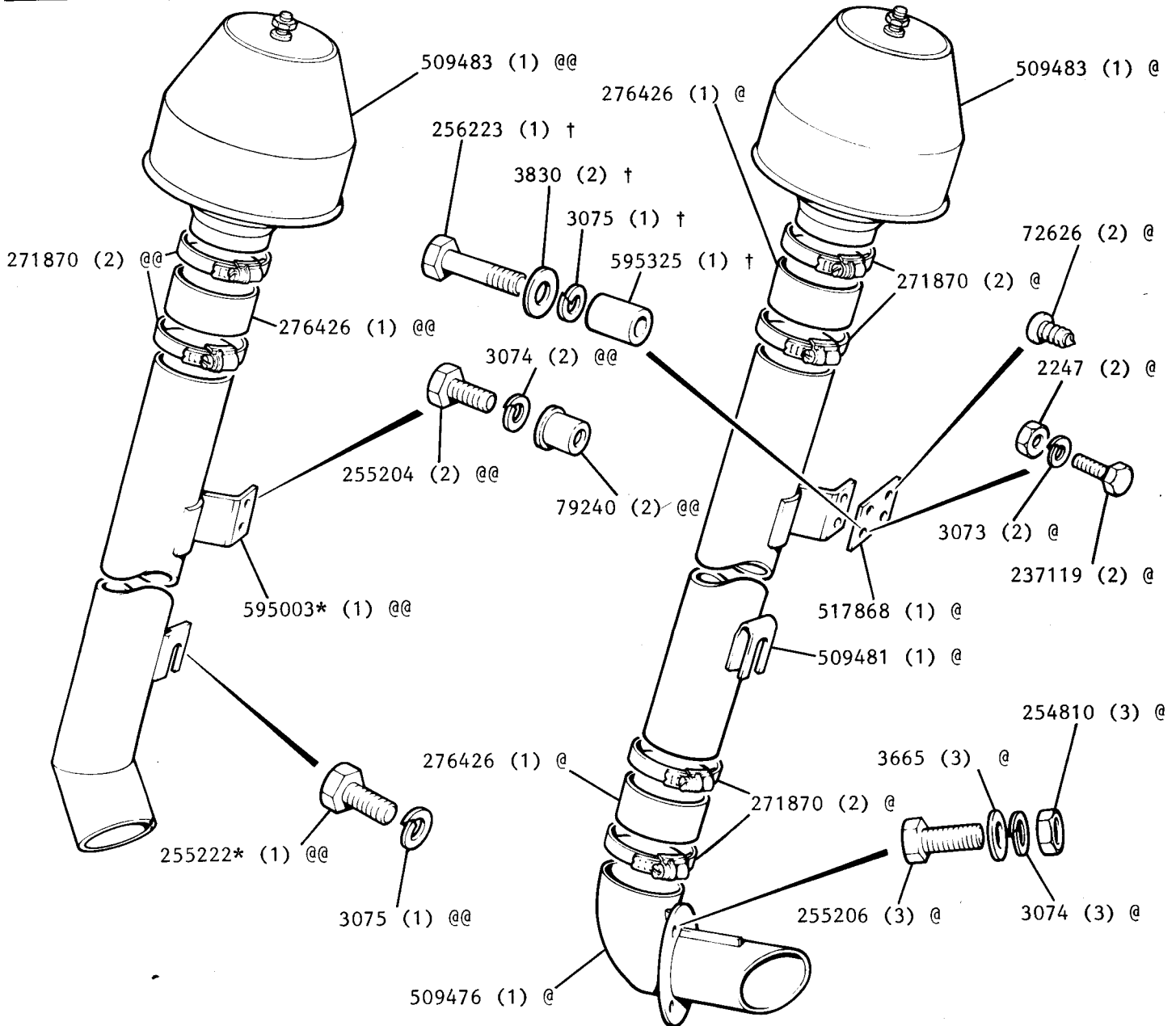

REMARKS

- Raised Air Intake Kit 517057 (1) @
- Raised Air Intake Kit 608156\* (1) @@ 2½ petrol and diesel
- Raised Air Intake Kit 608154\* (1) @@ 2.6 Petrol

@Series IIA

@@Series III

† To enable Series IIA Raised Air Intake Kit 517057 to be fitted to Series III 2½ R H Stg vehicles without servo and 2½ L H Stg vehicles without heater

CRANKCASE EMISSION CONTROL SERIES IIA 2¼ PETROL

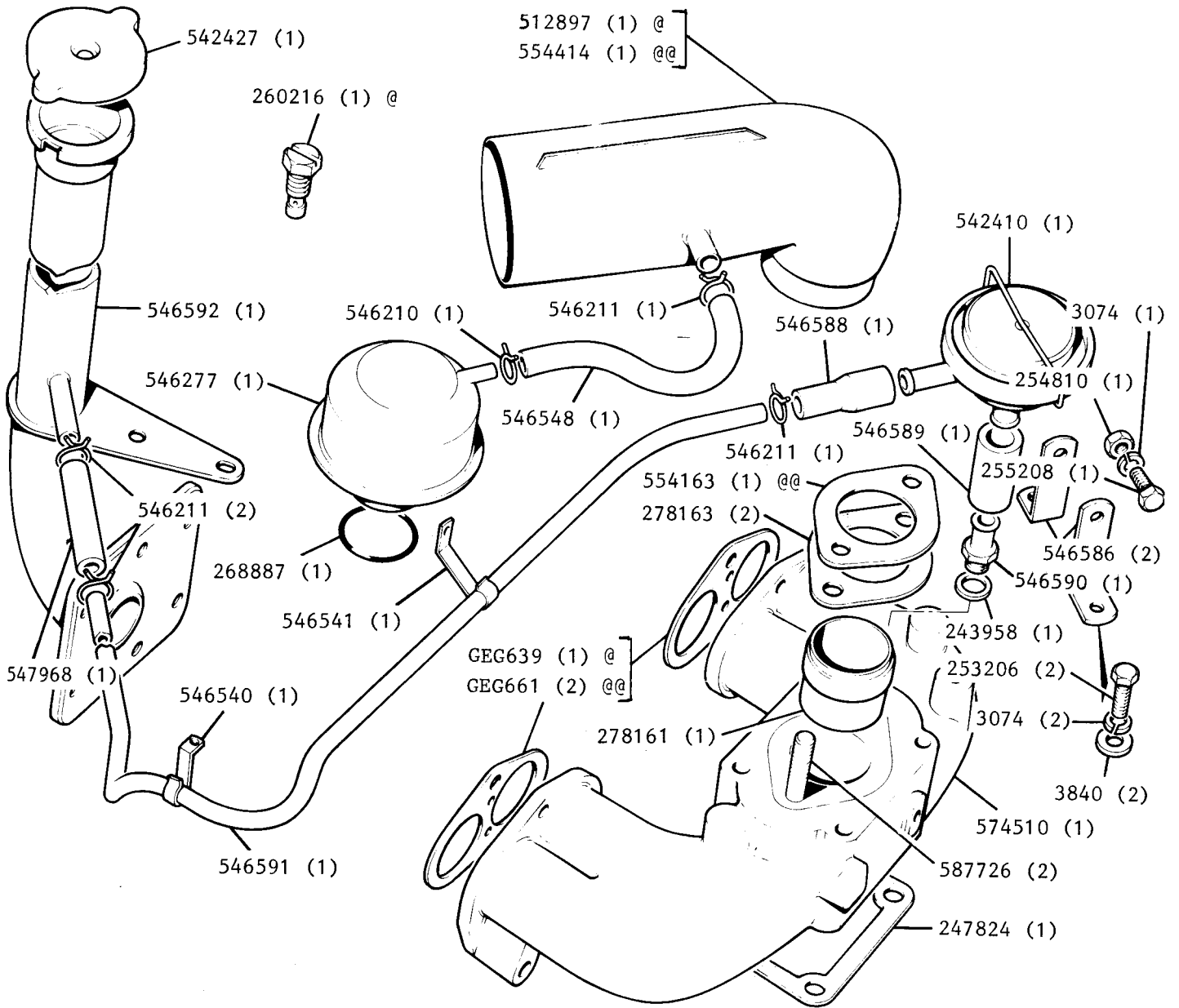

REMARKS

Crankcase Emission Control Kit 600493 (1) @  
 Crankcase Emission Control Kit 601734 (1) @@

@ Up to engine suffix H inclusive  
 @@ From engine suffix J onwards

CRANKCASE EMISSION CONTROL SERIES III

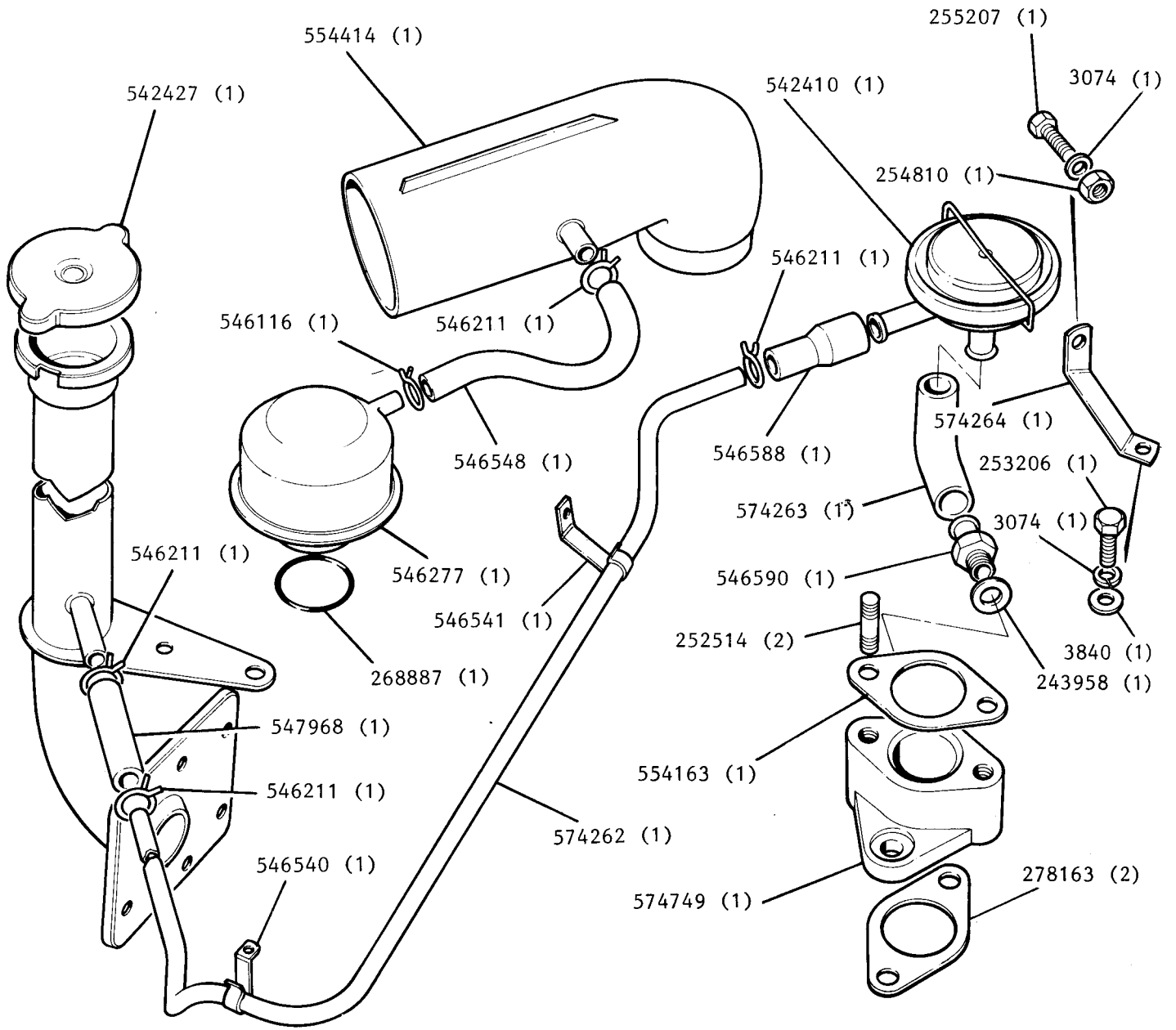

REMARKS

Crankcase Emission Control Kit 608385 (1)

DUST PROOFED ENGINE BREATHER SYSTEM SERIES IIA AND III 2½ PETROL

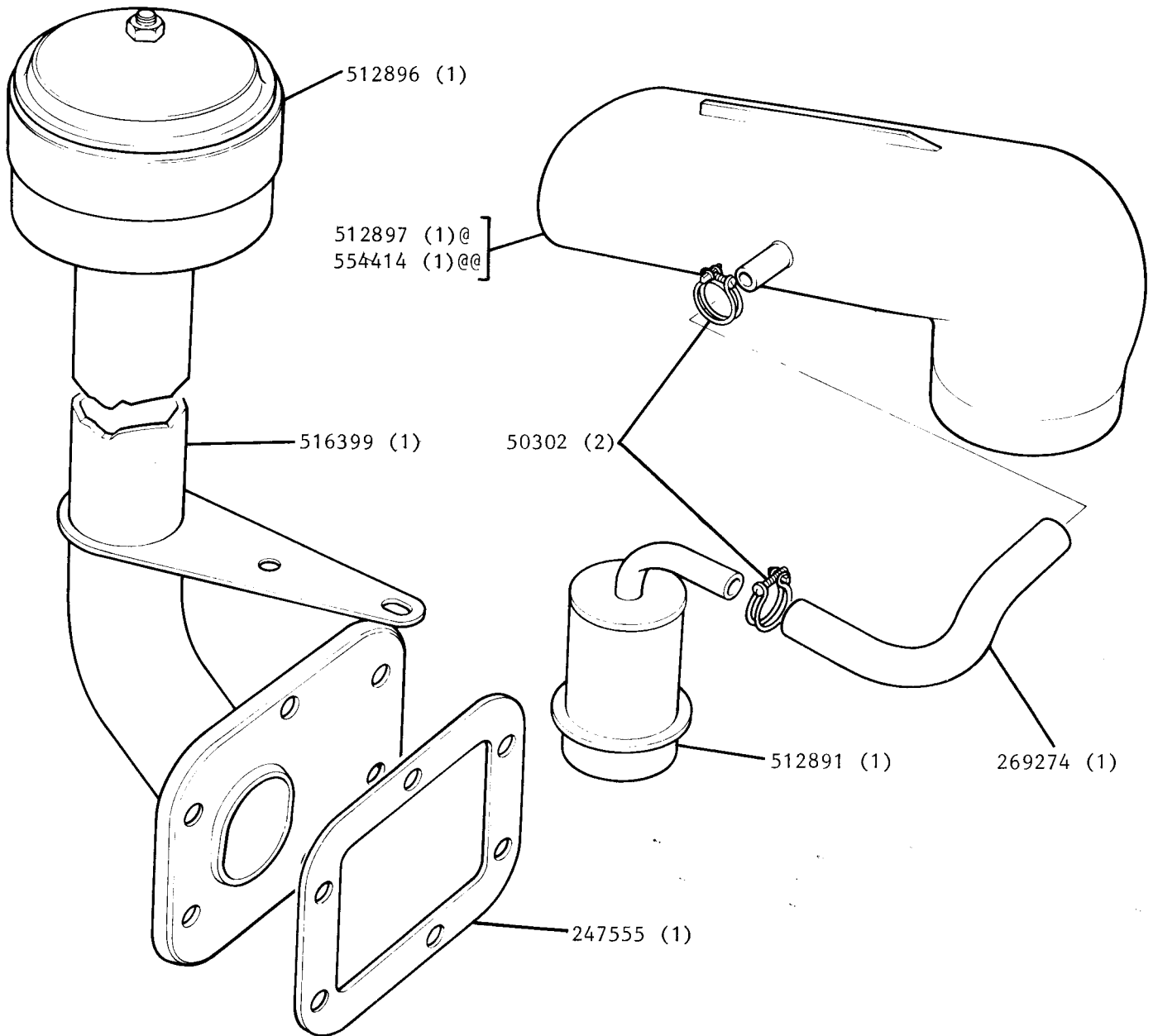

REMARKS

Dust Proofed Engine Breather Kit 517055 (1)@  
Dust Proofed Engine Breather Kit 601732 (1)@@

@ Up to engine suffix 'H' inclusive

@@ From engine suffix 'J' onwards



VENTILATED FUEL PUMP VALVE BODY, SHIELD, AND TUBING SERIES IIA AND III 2.6 PETROL

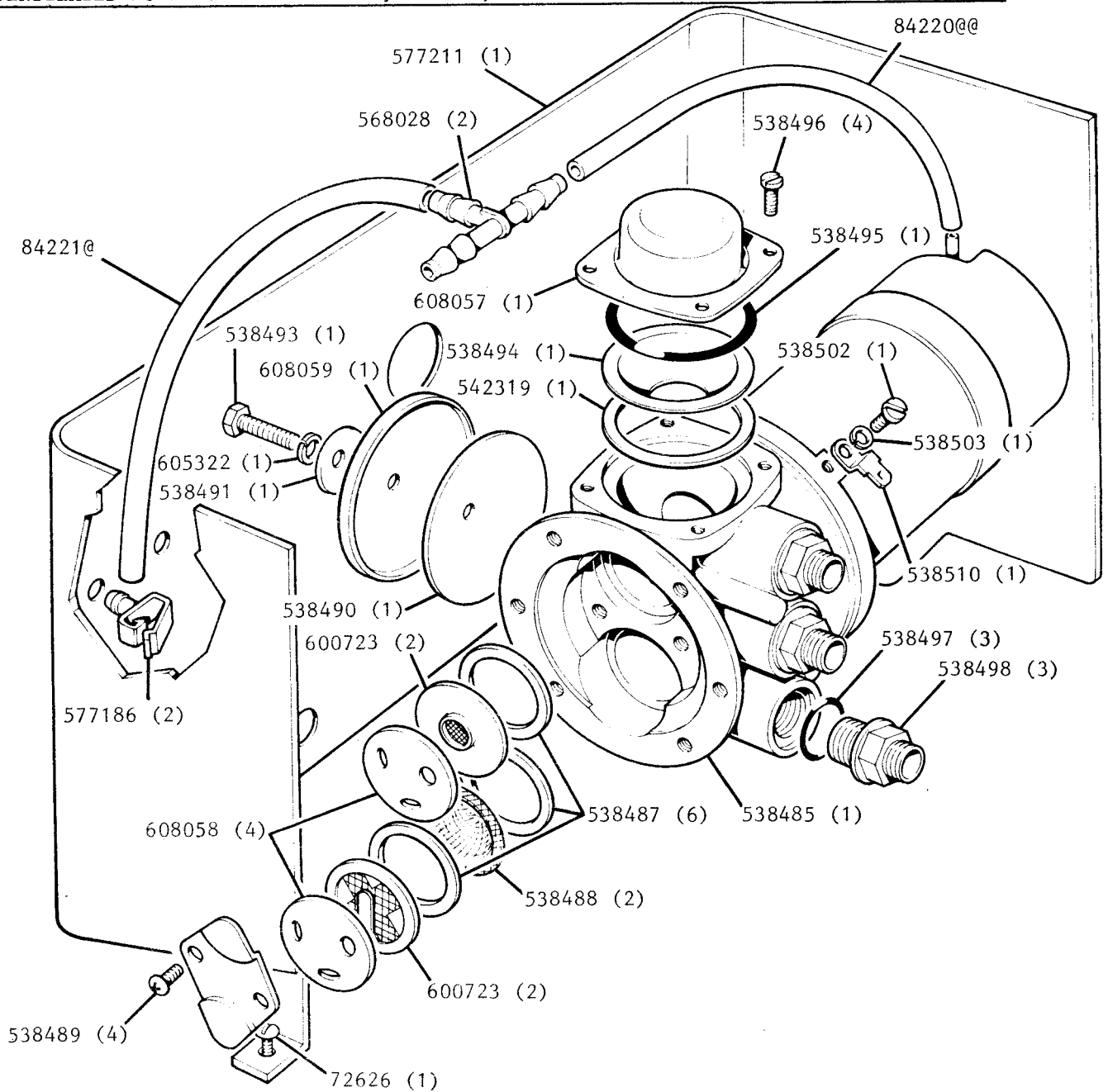

REMARKS

Fuel Pump complete 577203 (1)  
 @ 14 inches long, makes 2 off  
 @@ 24 inches long, makes 4 off

VENTILATED FUEL PUMP COIL, DIAPHRAGM AND PEDESTAL SERIES IIA AND III 2.6 PETROL

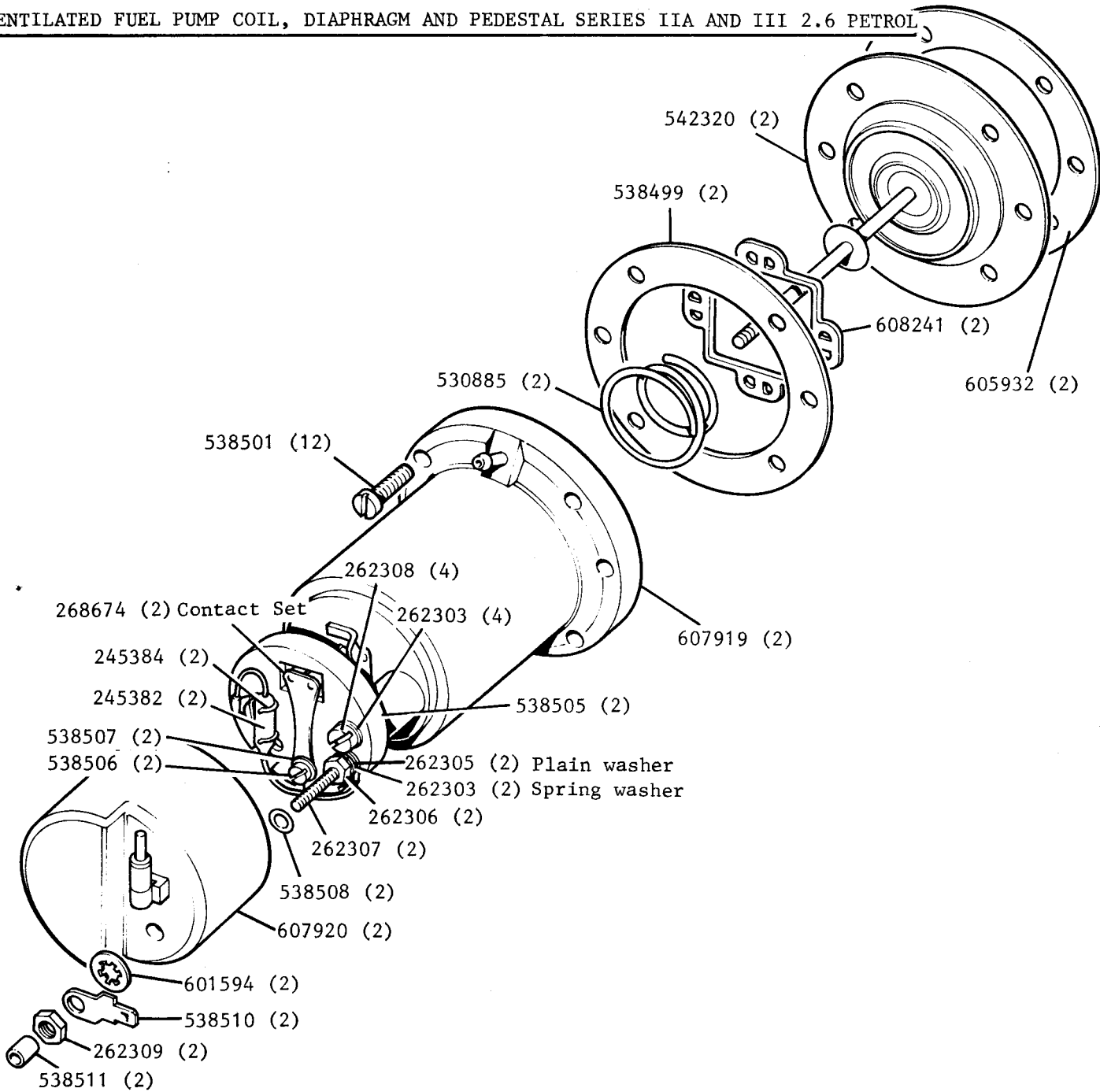

REMARKS

Fuel Pump Complete 577203 (1)

EXTRA FUEL FILTER SERIES 11A AND 111 DIESEL MODELS

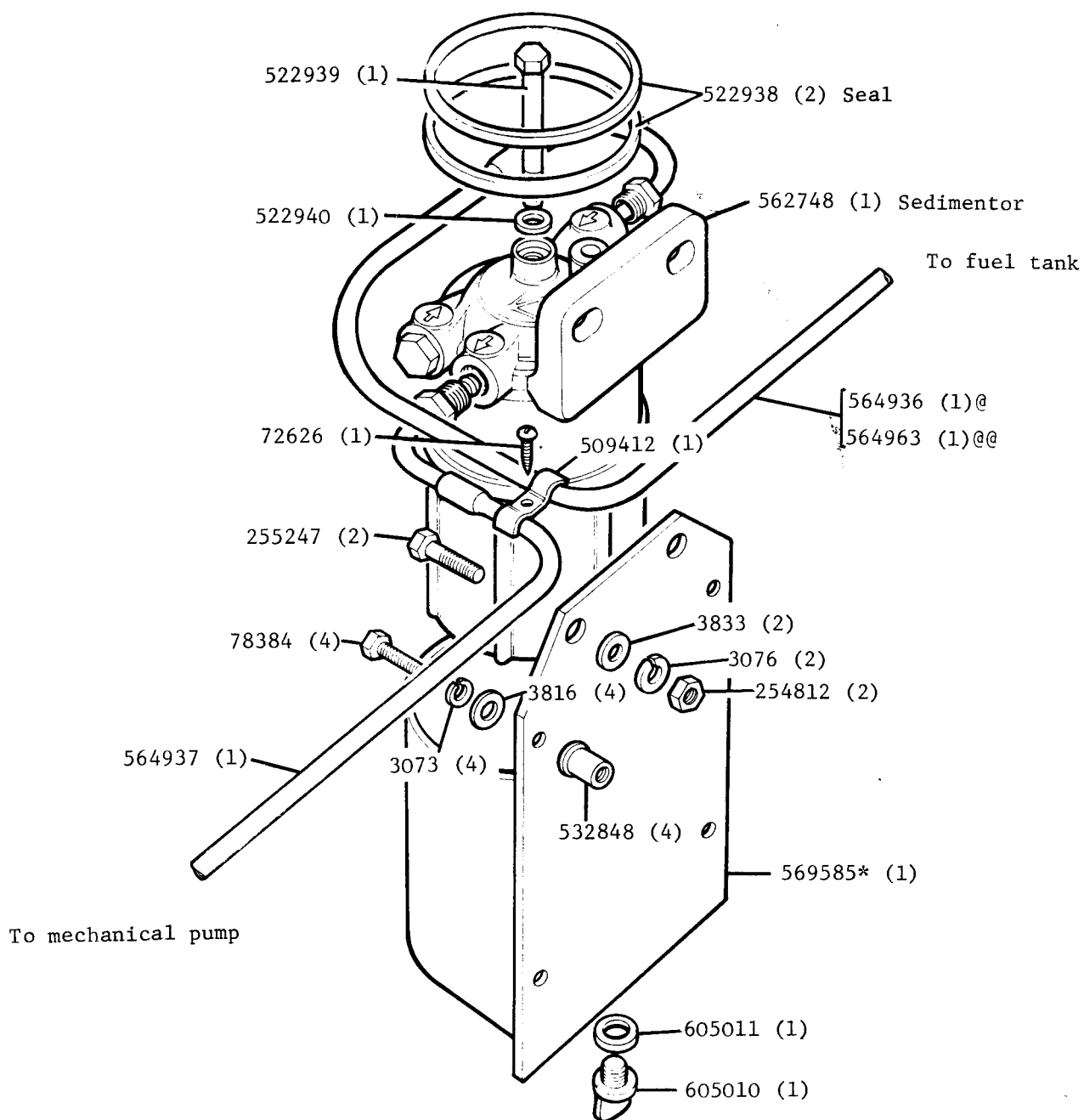

REMARKS

Sedimentor Complete Assembly 605560(1)@ }  
 Sedimentor Complete Assembly 605561 (1)@@ } Comprises all items on this frame.  
 Standard fitting on all export models, optional for home market models.  
 @ 88in and 109in long 2¼ litre diesel models  
 @@ 109in Station Wagon 2¼ litre diesel

AUXILIARY FUEL TANK COVER PANEL, TANK AND FIXINGS SERIES IIA AND III 109 in. 2.6

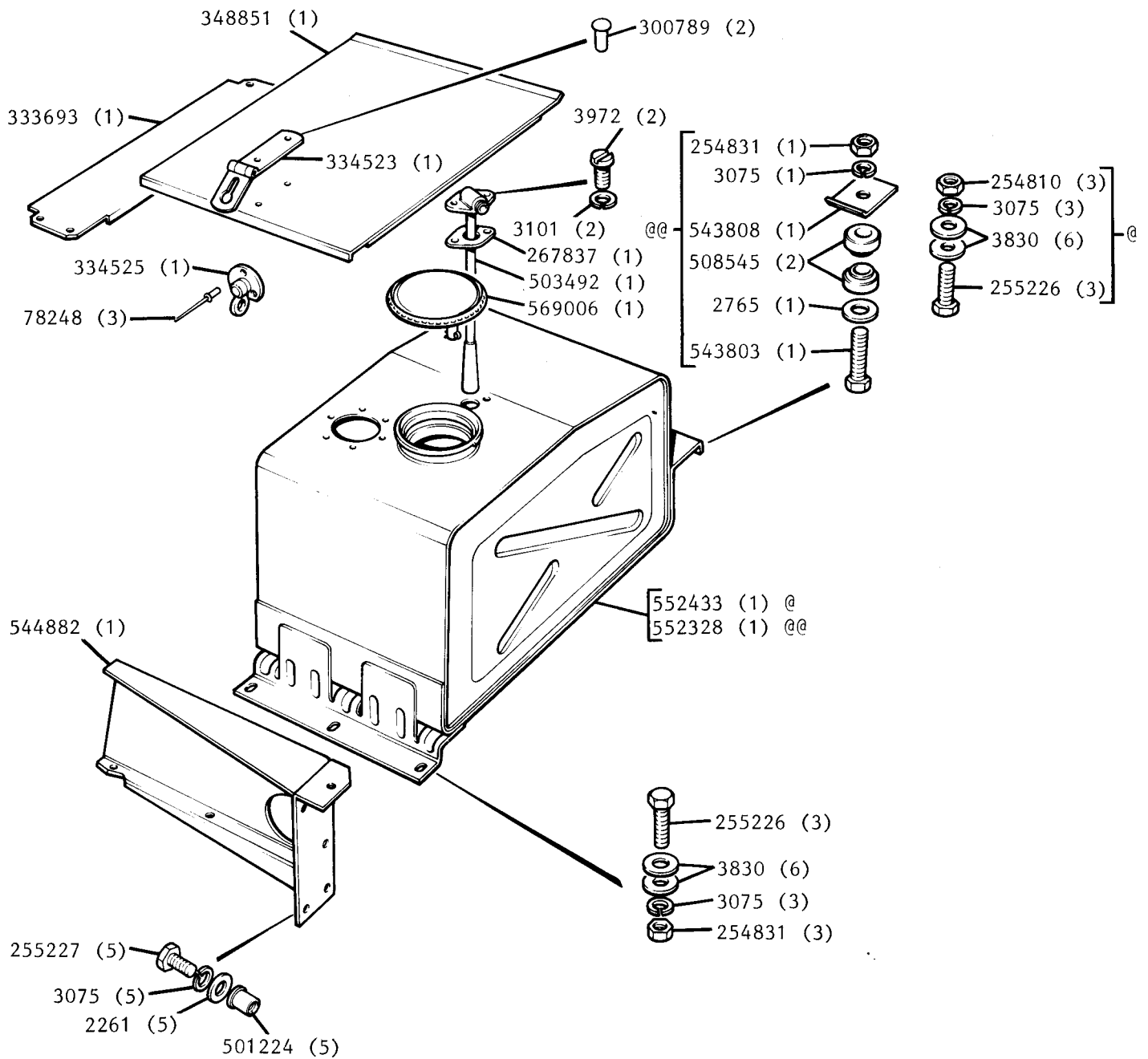

REMARKS

@ Three fixings at rear of tank

@@ One fixing at rear of tank

Auxiliary Fuel Tank Kit 605401 Series IIA

Auxiliary Fuel Tank Kit 607806 Series III

AUXILIARY FUEL TANK TWO WAY COCK, PIPES AND GAUGE UNIT, SERIES IIA AND III 109 in 2.6,

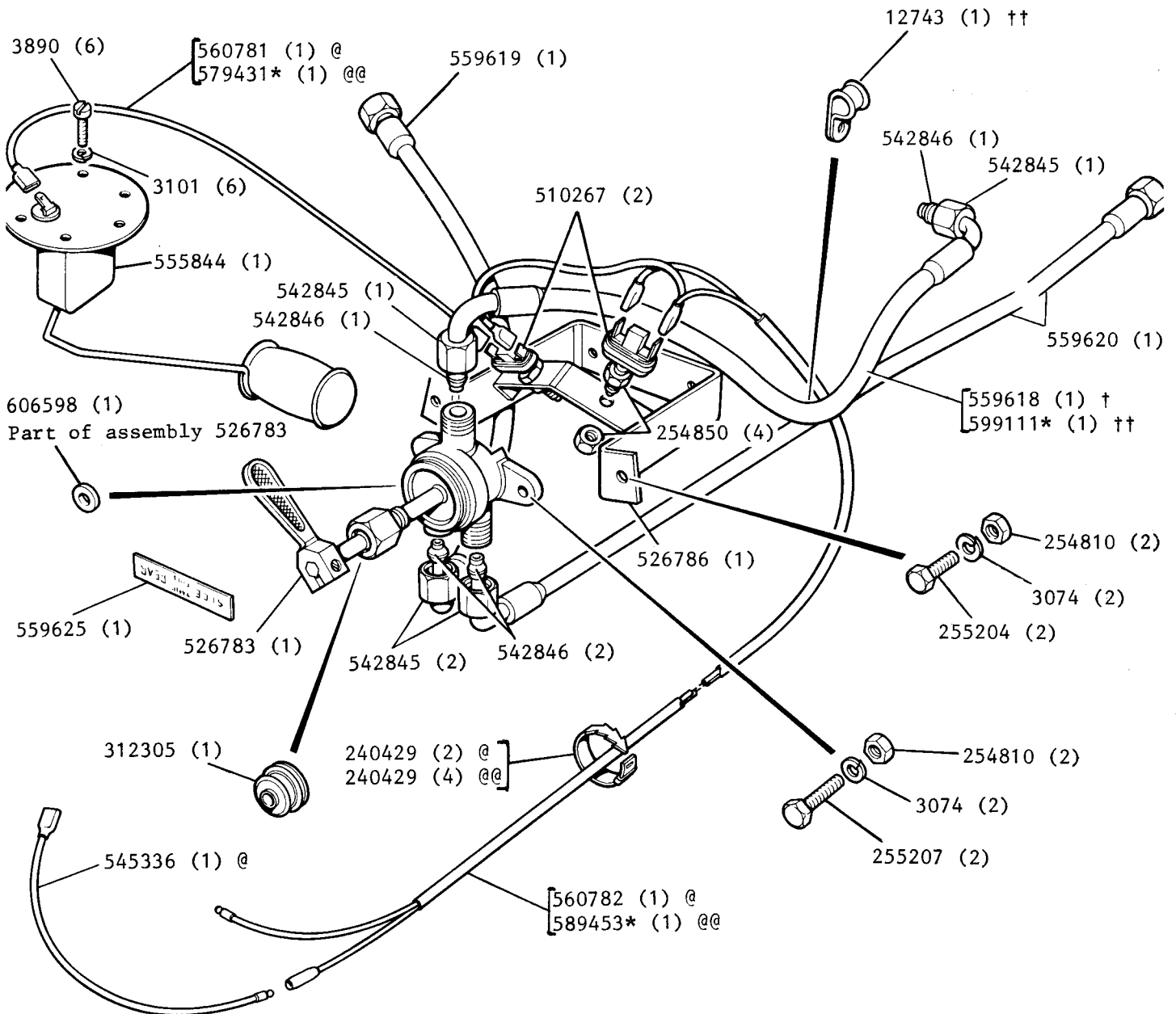

REMARKS

Auxiliary Fuel Tank Kit 605401 @  
 Auxiliary Fuel Tank Kit 607806 @@  
 @ Series IIA  
 @@ Series III

† When twin S.U. fuel pump is fitted  
 †† When Bendix fuel pump is fitted

REAR AND CENTRE POWER TAKE-OFF GEARBOX UNIT ASSEMBLY  
SERIES IIA AND III 88 in AND 109 in EXCEPT 109 in STATION WAGON

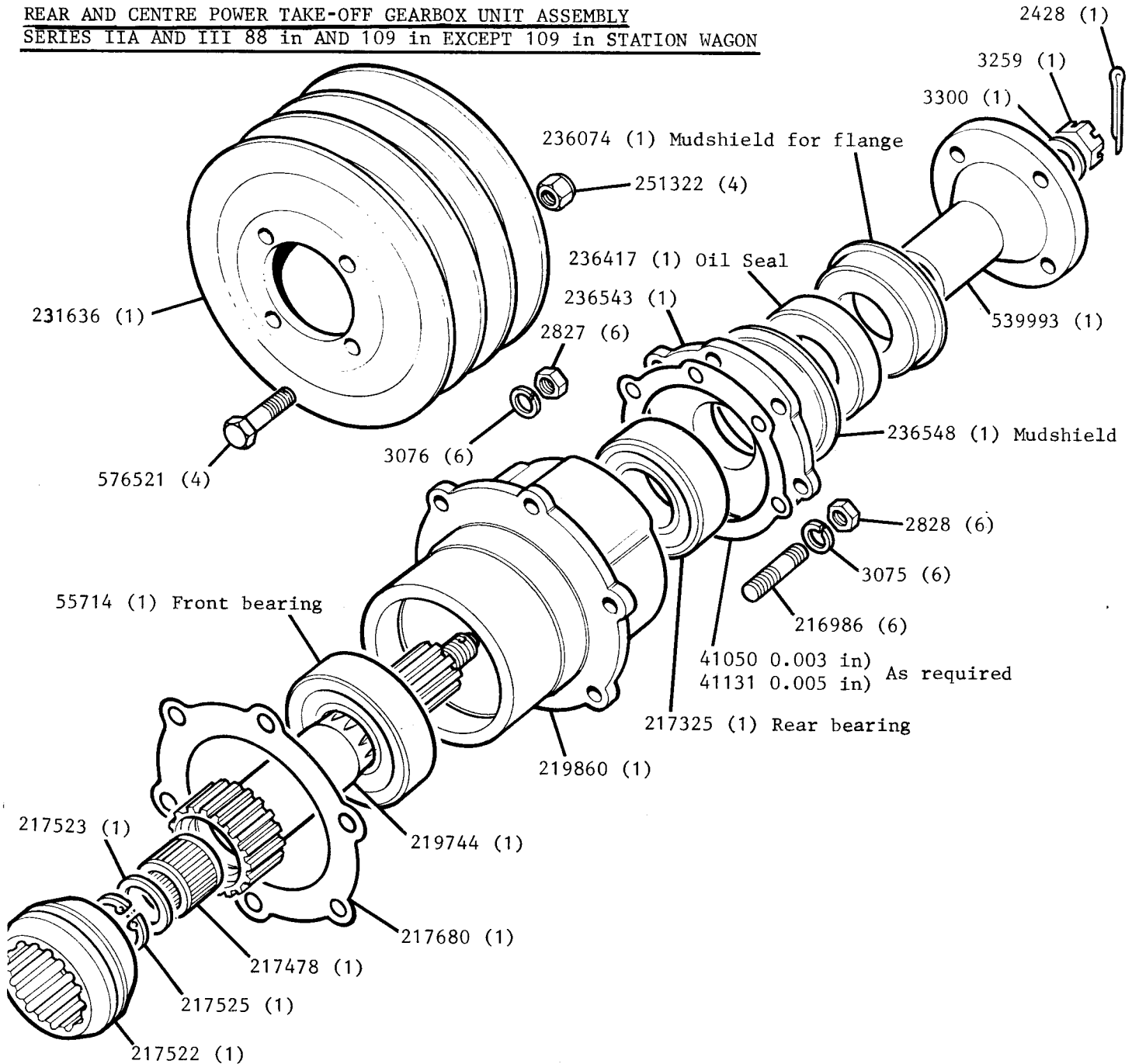

REMARKS

Power Take-Off Gearbox Unit Assembly 230855 (1)  
Rear Power Take-Off Kit 241706 (1) 88 in )  
Rear Power Take-Off Kit 501680 (1) 2¼ ) Series IIA ) Must be used  
Rear Power Take-Off Kit 605352 (1) 2.6 ) 109 in ) in conjunction  
Rear Power Take-Off Kit 606876\* (1) 88 in ) ) with towing  
Rear Power Take-Off Kit 606877\* (1) 2¼ ) ) equipment  
Rear Power Take-Off Kit 606891\* (1) 2.6 ) Series III ) 501683 for  
) 2¼ models and  
) 606008 for  
) 2.6 models

Centre Power Take-Off Kit 261835 (1) 2¼ )  
Centre Power Take-Off Kit 605928 (1) 2.6 ) Less Centre Pulley

REAR AND CENTRE POWER TAKE-OFF SELECTOR UNIT  
SERIES 11A AND 111 88in AND 109in EXCEPT 109in STATION WAGON

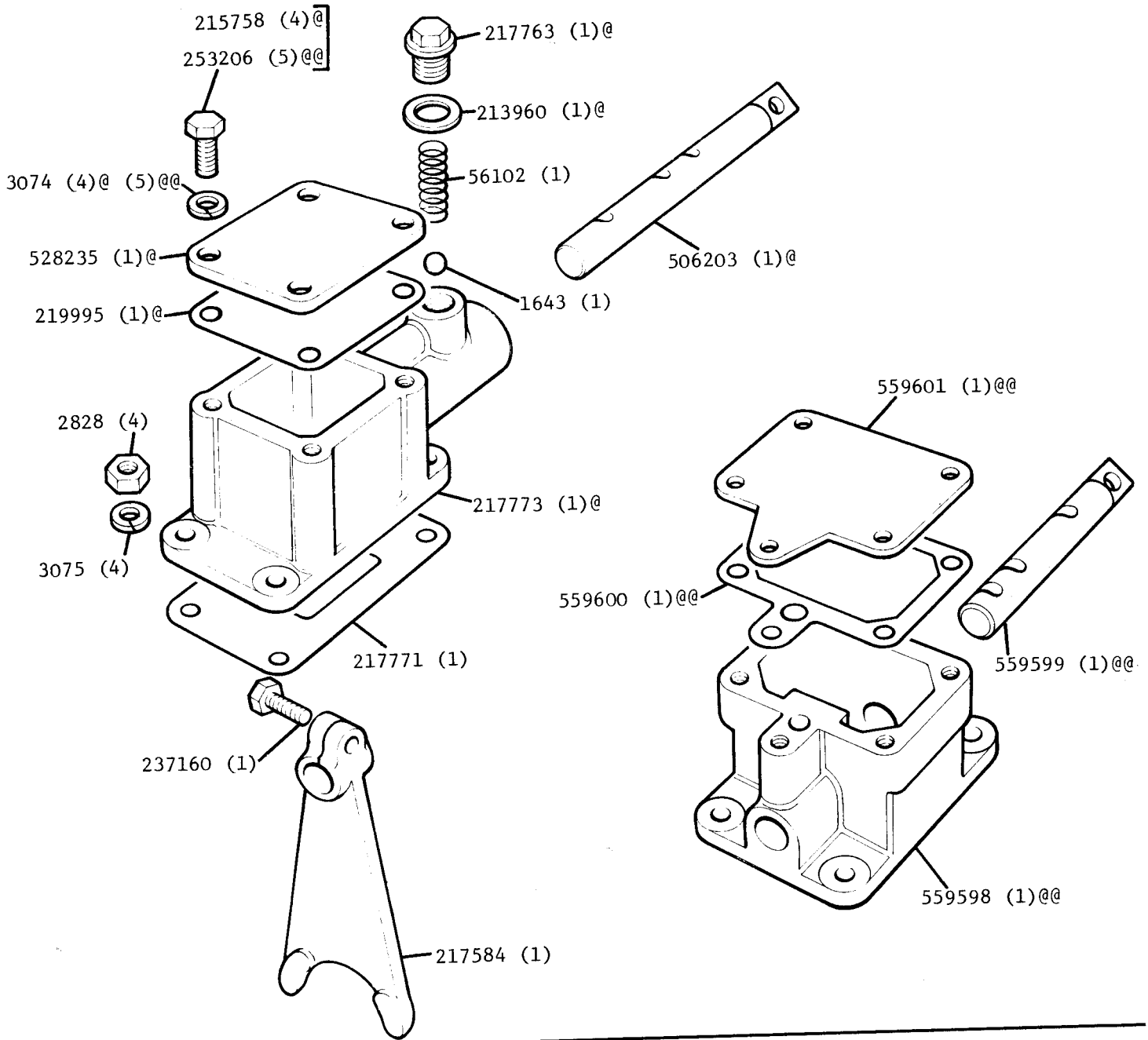

REMARKS

Power Take-Off Selector Unit Assembly 509076 (1)@  
 Power Take-Off Selector Unit Assembly 559597 (1)@@  
 @ 2¼ Litre Models  
 @@ 2.6 Litre Models  
 For rear and centre power take-off kit part numbers see  
 frame 25 15

REAR AND CENTRE POWER TAKE-OFF SELECTOR ROD AND LEVER FOR SERIES 11A AND 111 88in AND 109in  
EXCEPT 109in STATION WAGON

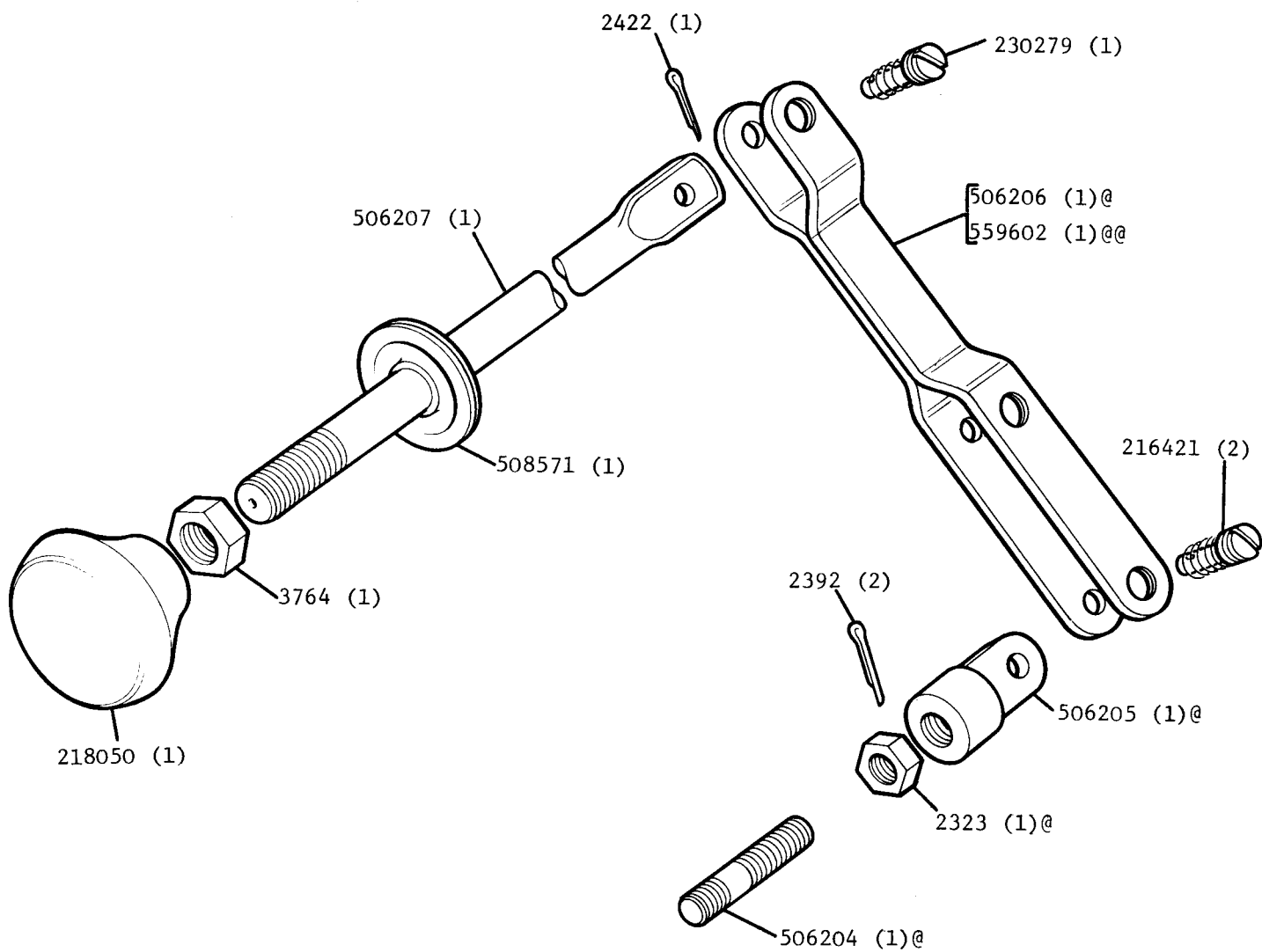

REMARKS

@ 2½ litre models

@@ 2.6 litre Models

For rear and centre power take-off kit part numbers see  
frame 25 15



88in PROPELLOR SHAFT, 109in FRONT PROPELLOR SHAFT AND INTERMEDIATE SUPPORT BRACKET. SERIES 11A AND 111 EXCEPT 109in STATION WAGON

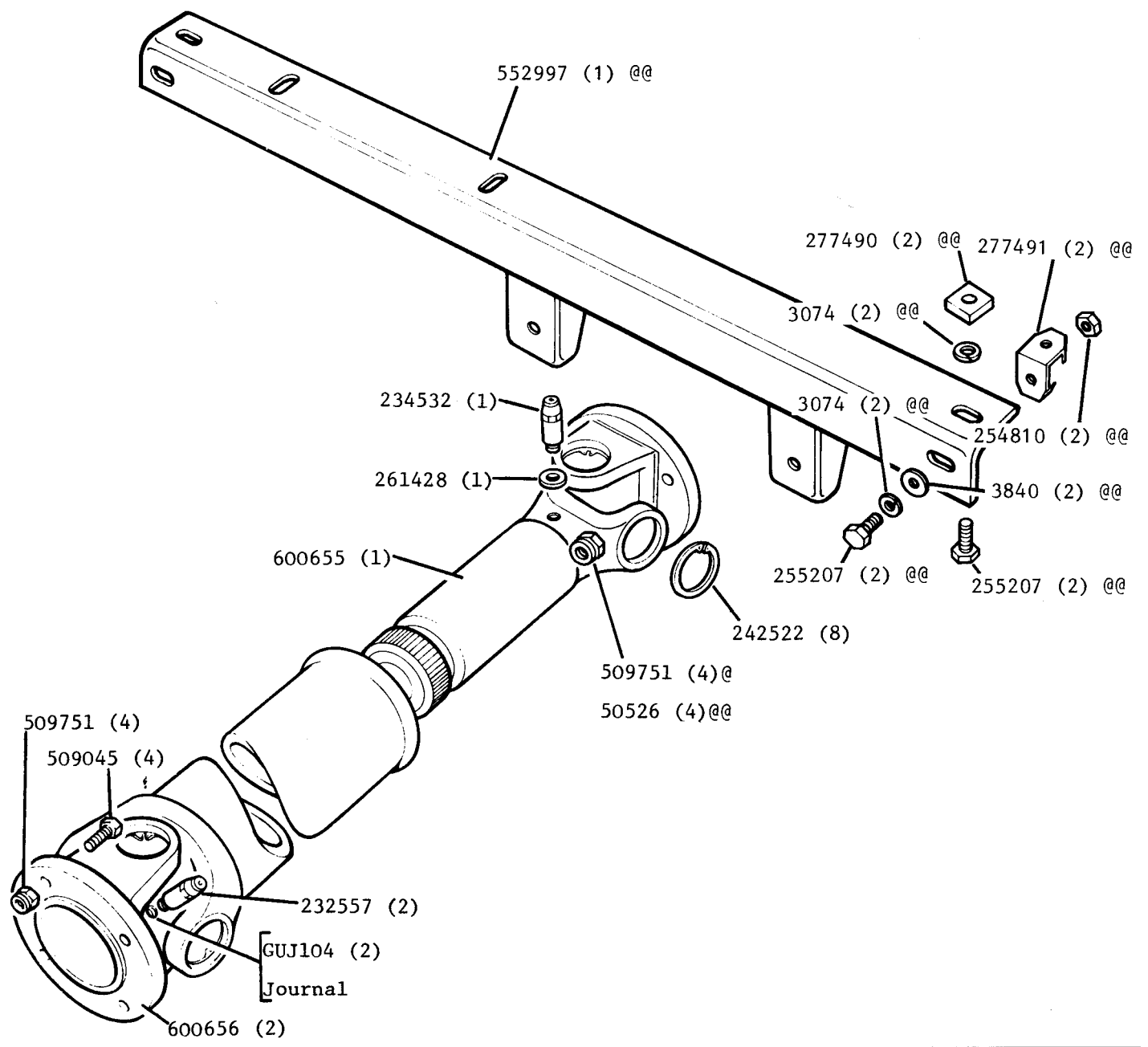

REMARKS

Propellor shaft 533728 2¼ litre models  
 Propellor shaft 559564 2.6 litre Models

@ 88in.

@@ 109 in.

For rear and centre power take-off kit part numbers see frame 25 15

REAR POWER TAKE-OFF REAR PROPELLOR SHAFT SERIES 11A and 111 109in.  
 EXCEPT STATION WAGON

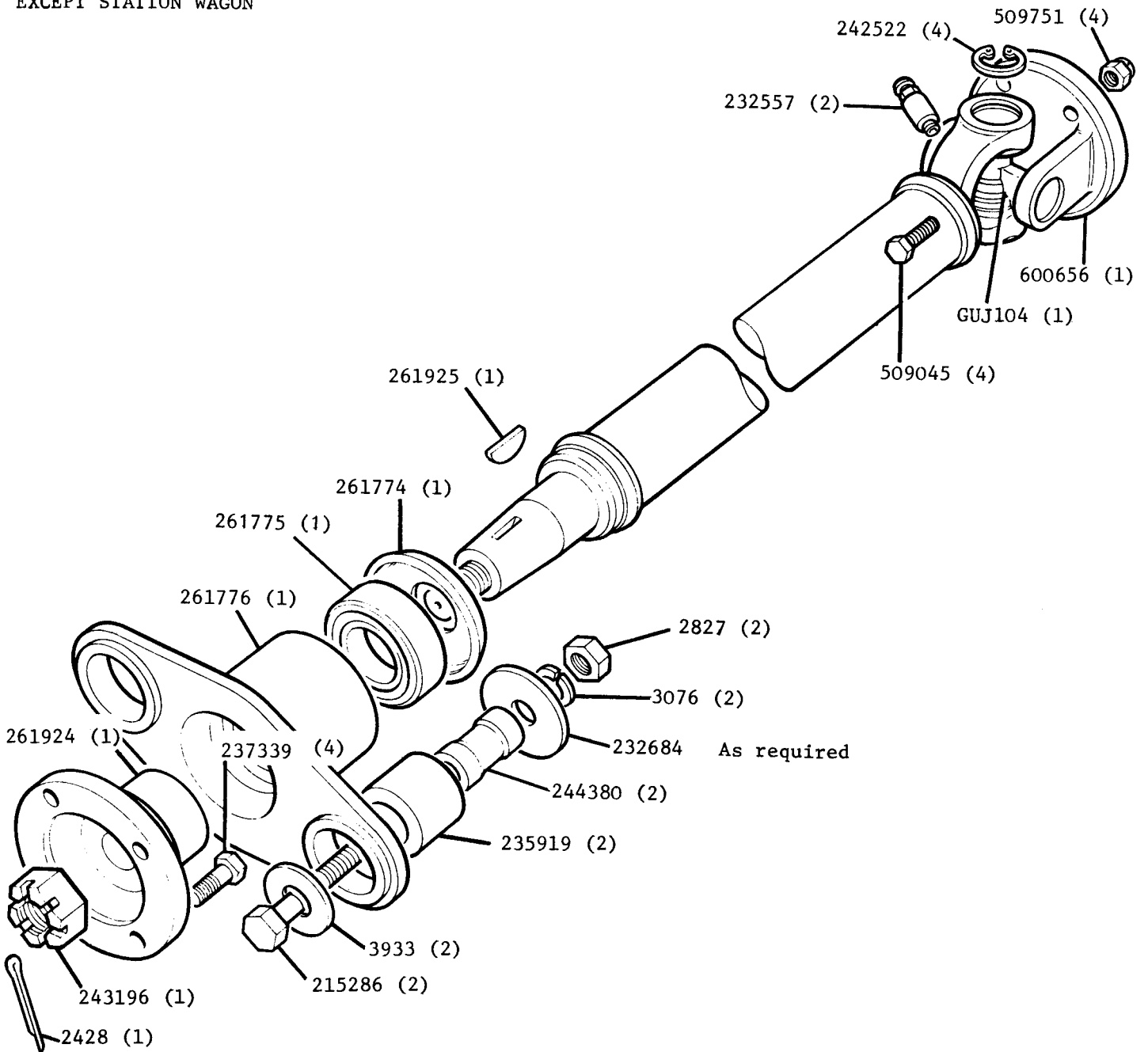

REMARKS

Propellor Shaft Assembly 533727 (1) Comprises all items on this frame.  
 For rear and centre power take-off kit part numbers see  
 frame 25 15

REAR POWER TAKE-OFF DRIVE SECTION. SERIES 11A AND 111  
88in AND 109in EXCEPT 109in STATION WAGON

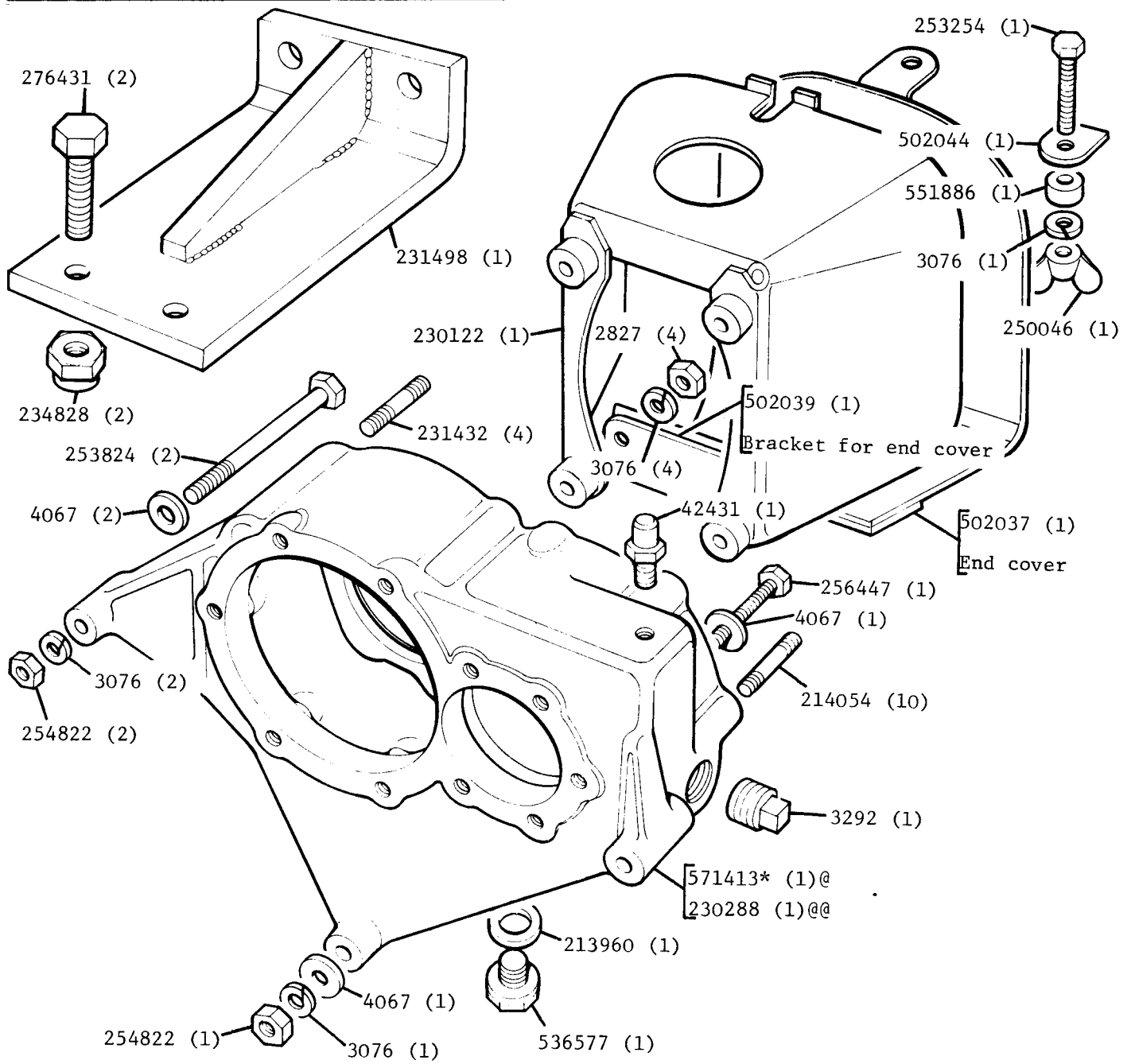

REMARKS

Power take-off drive section 1.389:1 ratio 571410\* (1)@  
 Power take-off drive section 1.2:1 ratio 230176 (1)@@  
 @ Series 111 Land Rover  
 @@ Series 11A Land Rover  
 For rear and centre power take-off kit part numbers see  
 frame 25 15

INPUT SHAFT FOR REAR POWER TAKE-OFF DRIVE SECTION  
SERIES 11A AND 111 88in AND 109in EXCEPT 109in STATION WAGON

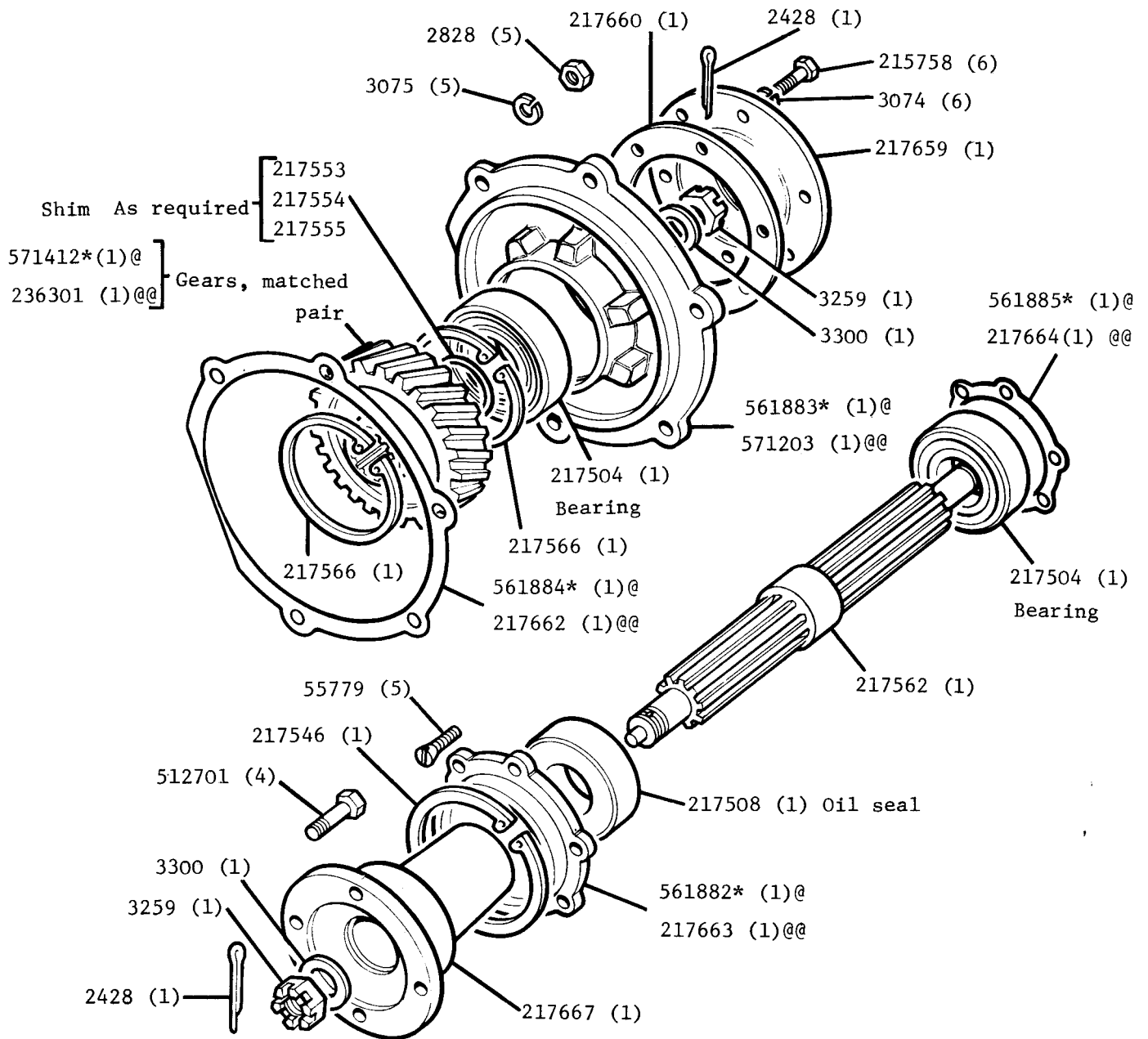

REMARKS

Power take-off drive section 1.389: 1 ratio 571410\*(1)@

Power take-off drive section 1.2:1 ratio 230176 (1)@@

@ Series 111 Land Rover

@@ Series 11A Land Rover

For rear and centre power take-off kit part numbers see frame 25 15

OUTPUT SHAFT FOR REAR POWER TAKE-OFF DRIVE SECTION  
SERIES 11A AND 111 88in AND 109in EXCEPT 109in STATION WAGON

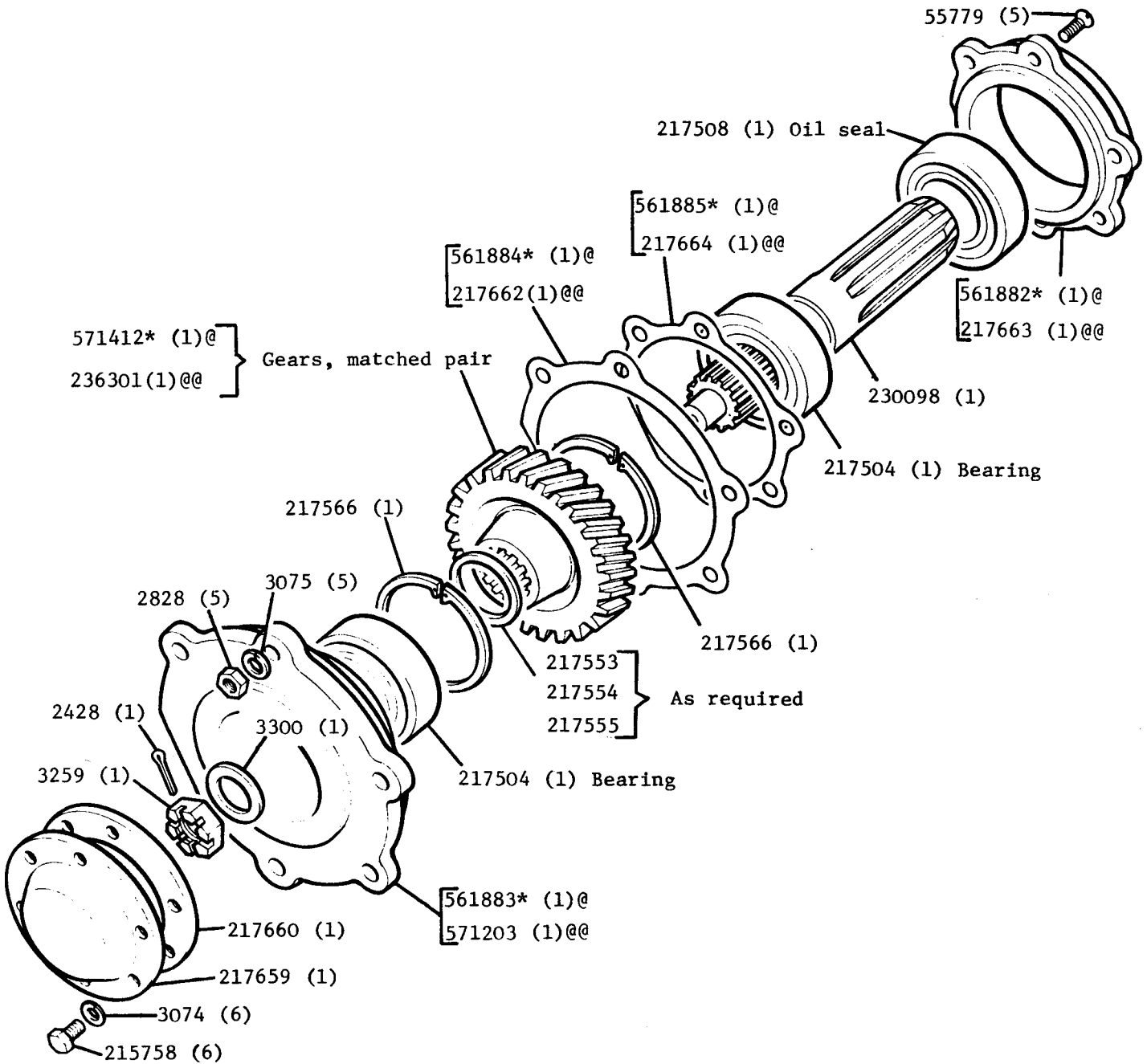

REMARKS

Power take-off drive section 1.389:1 ratio 571410 \*(1)@  
 Power take-off drive section 1.2:1 ratio 230176 (1)@@  
 @ Series 111 Land Rover  
 @@ Series 11A Land Rover  
 For rear and centre power take-off kit part numbers see  
 frame 25 15

REAR POWER TAKE-OFF PULLEY SECTION

SERIES IIA AND III 88in AND 109 in EXCEPT 109 in STATION WAGON

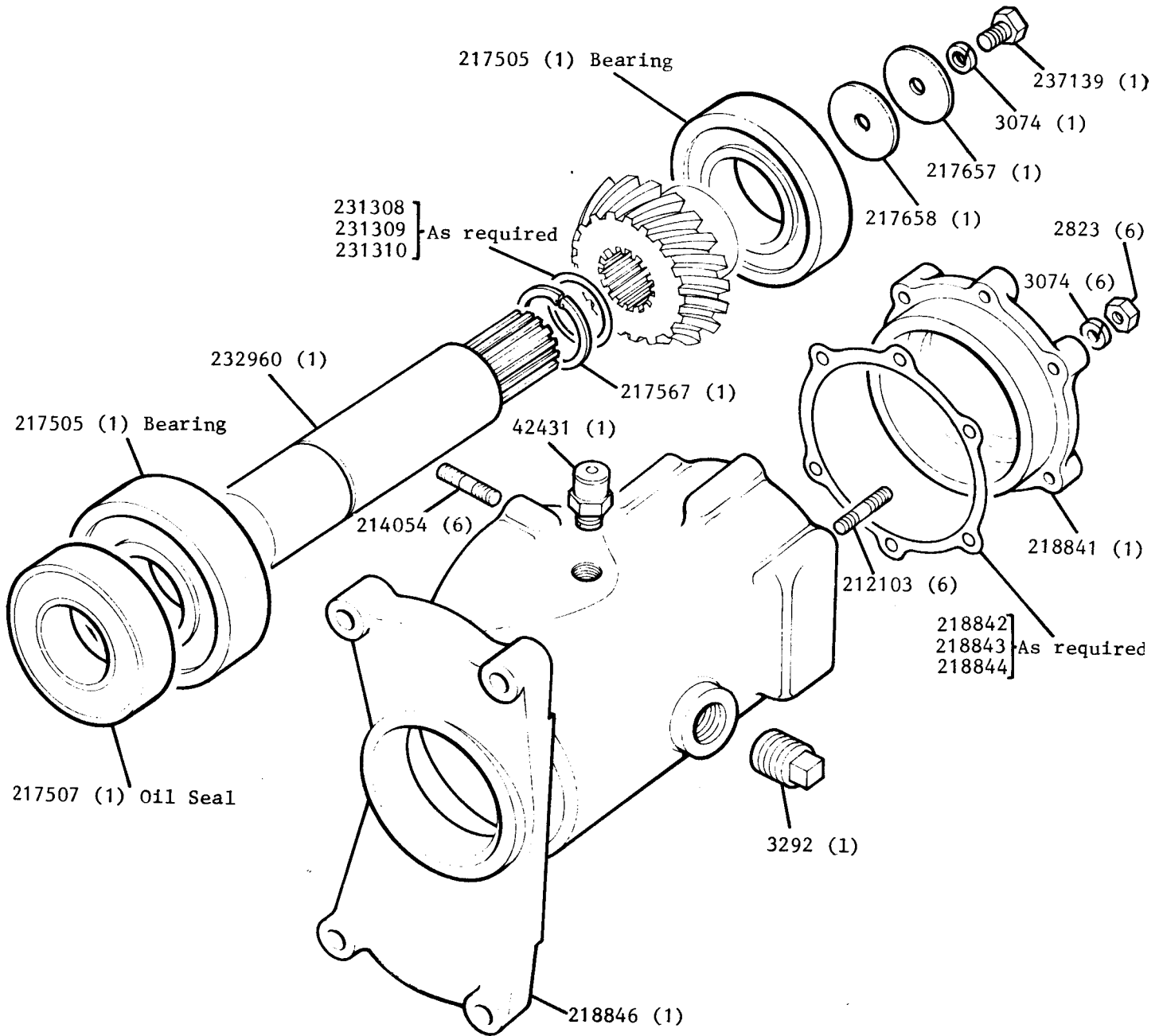

REMARKS

Power take-off assembly pulley section 230177 (1)  
For rear and centre power take-off kit part numbers see  
frame 25 15

REAR POWER TAKE-OFF PULLEY SECTION. SERIES 11A AND 111 88in AND 109in  
EXCEPT 109in STATION WAGON

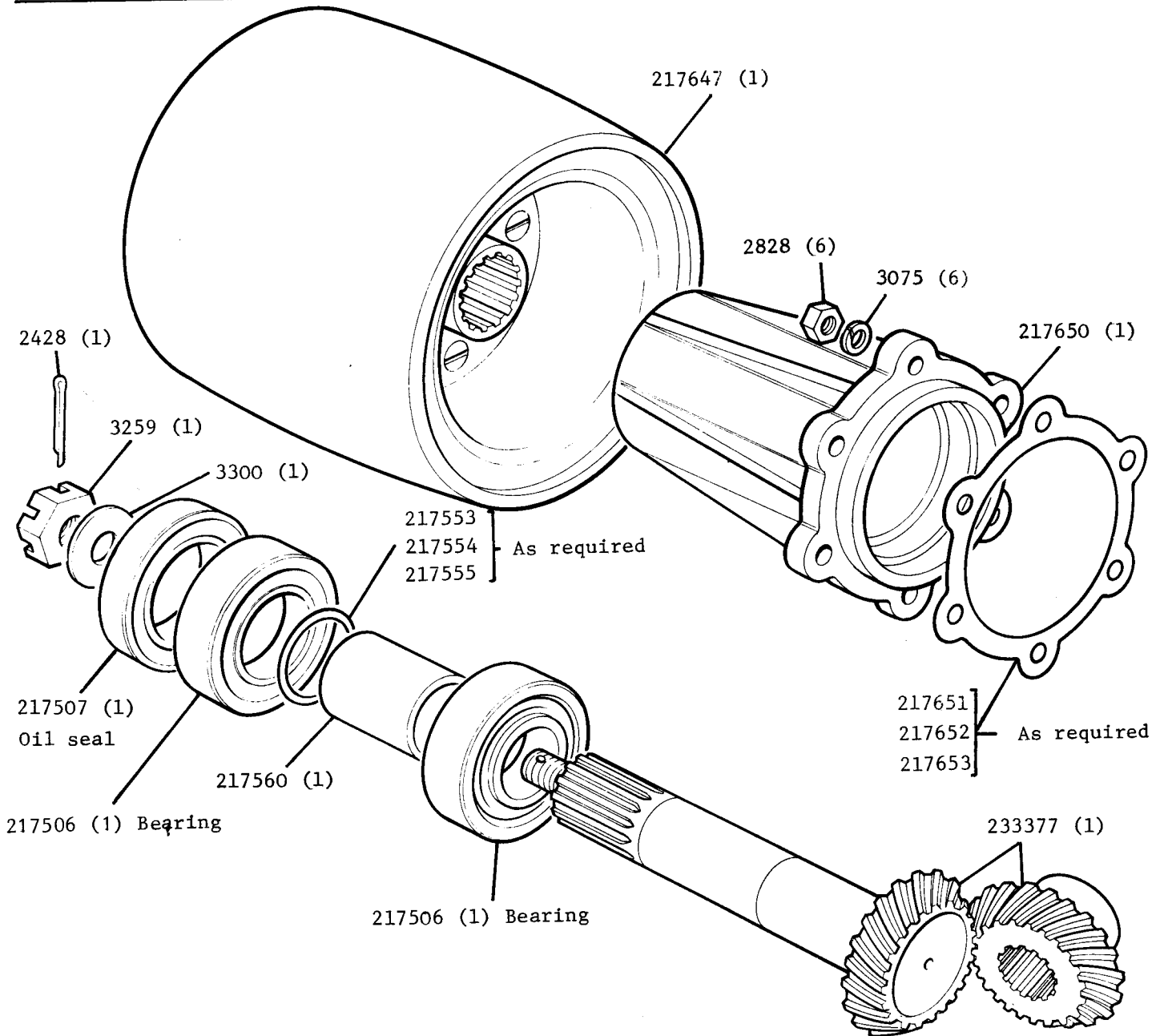

REMARKS

Power Take-off Assembly, pulley section 230177 (1)  
 For rear and centre power take-off kit part numbers see  
 frame 25 15

UNDERSHIELD, GEARBOX, SERIES IIA AND III 109 in.

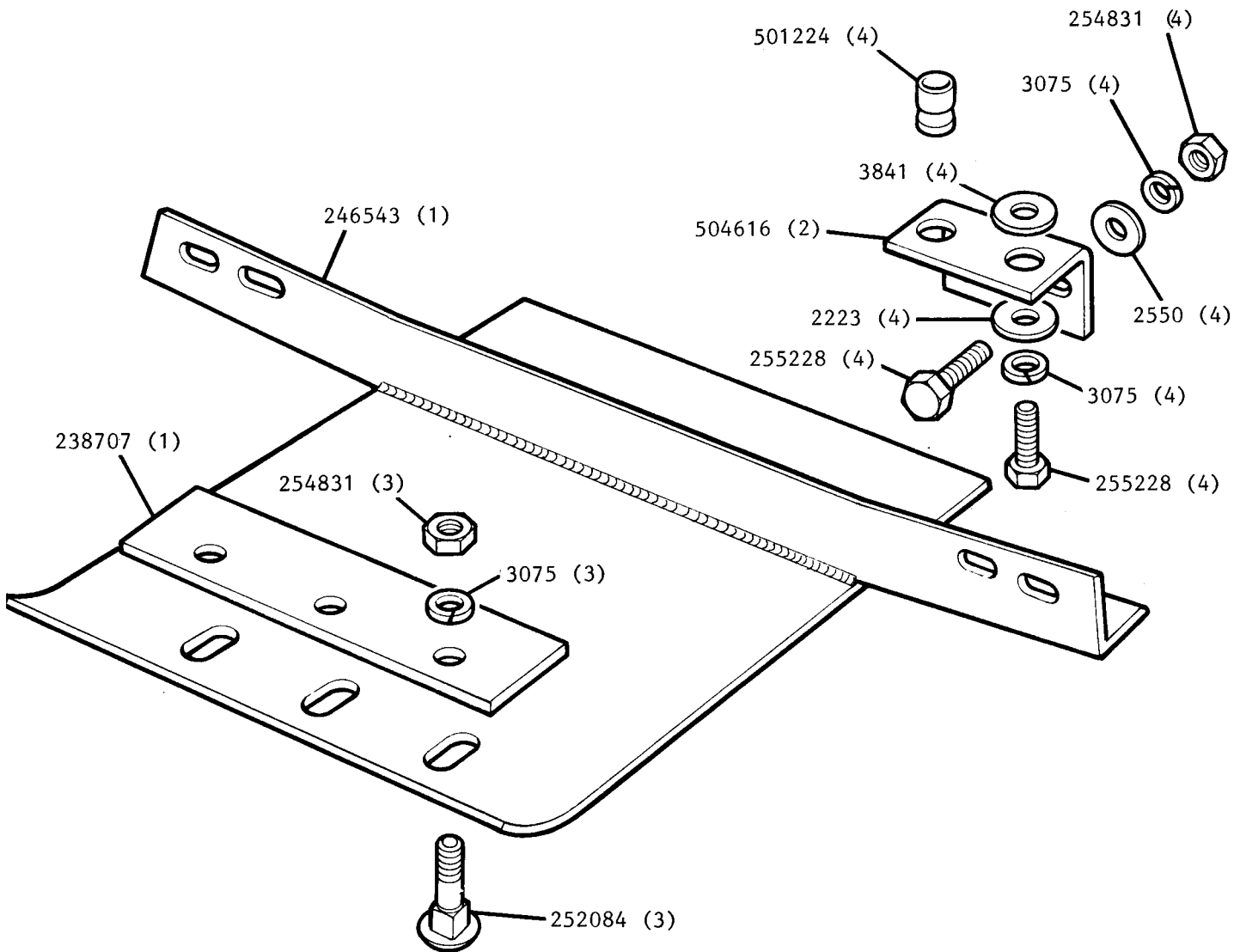

REMARKS

Undershield Kit. 607738\* (1) Fitted as standard to 109 in vehicles for Switzerland.



STEERING COLUMN LOCK SERIES IIA LH STG PETROL MODELS FROM JUNE 1968 ONWARDS

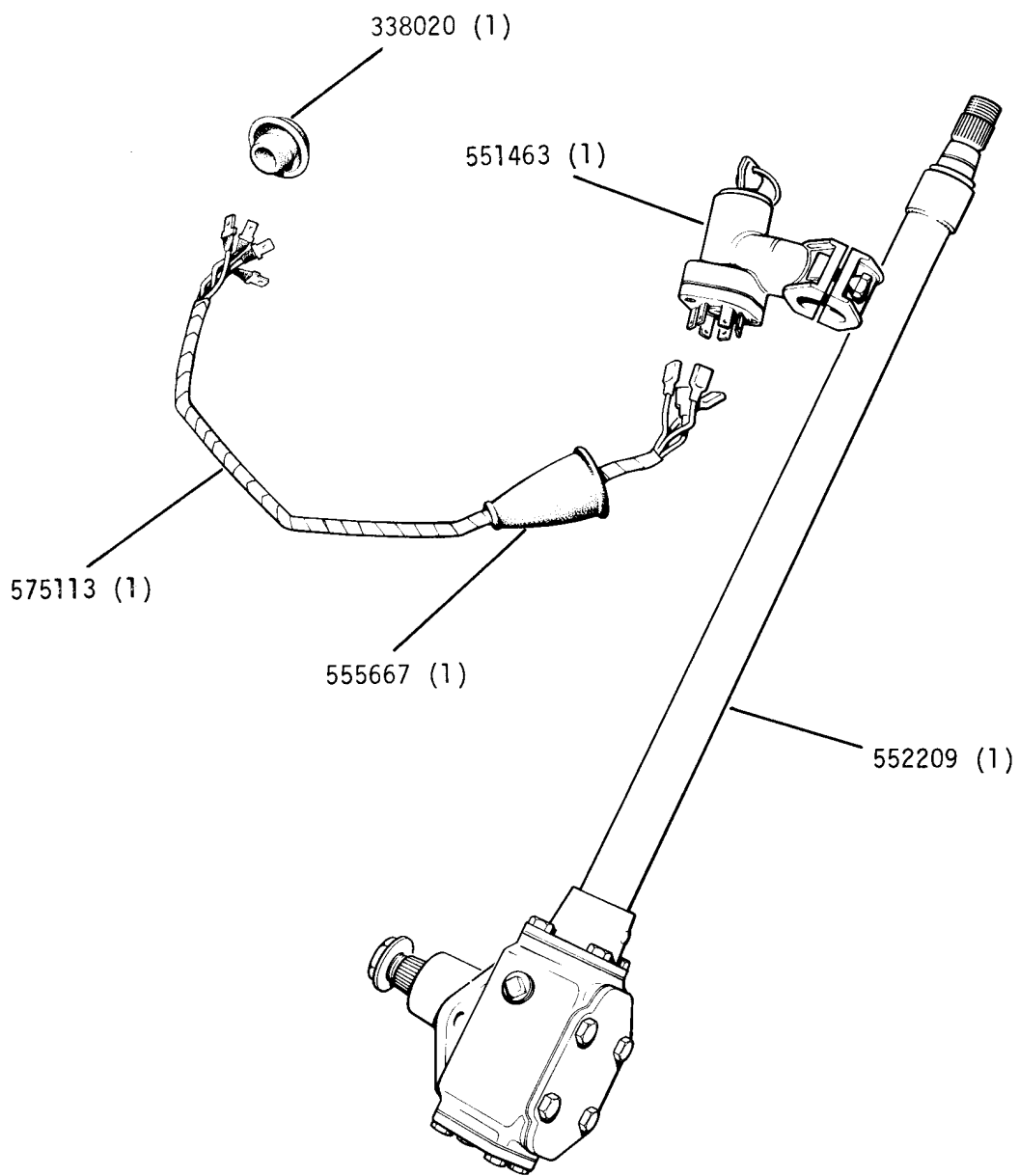

REMARKS

STEERING COLUMN LOCK SERIES III

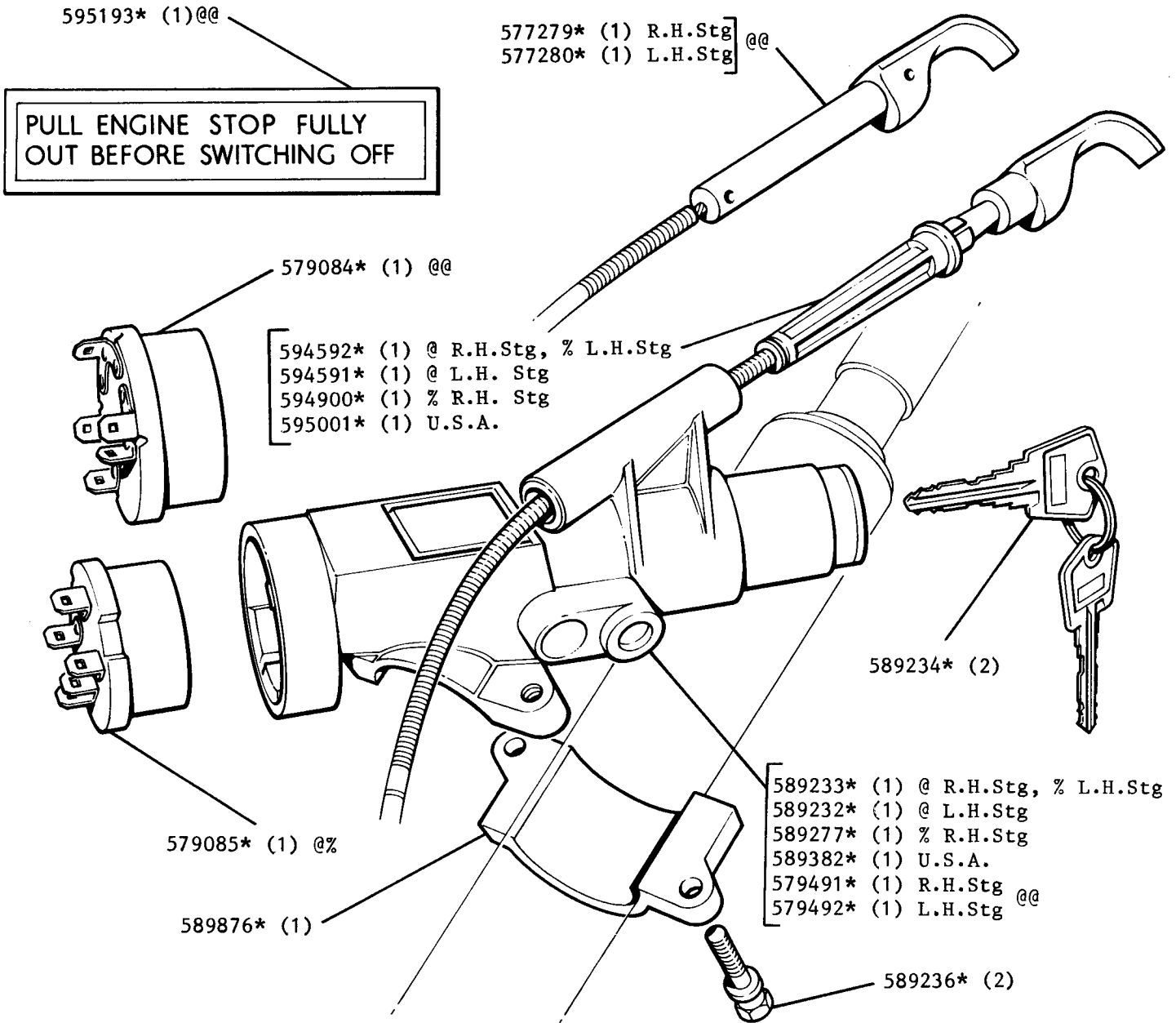

REMARKS

- @ 2½ petrol
- @@ 2½ diesel
- % 2.6 petrol

STEERING DAMPER SERIES 11A AND 111

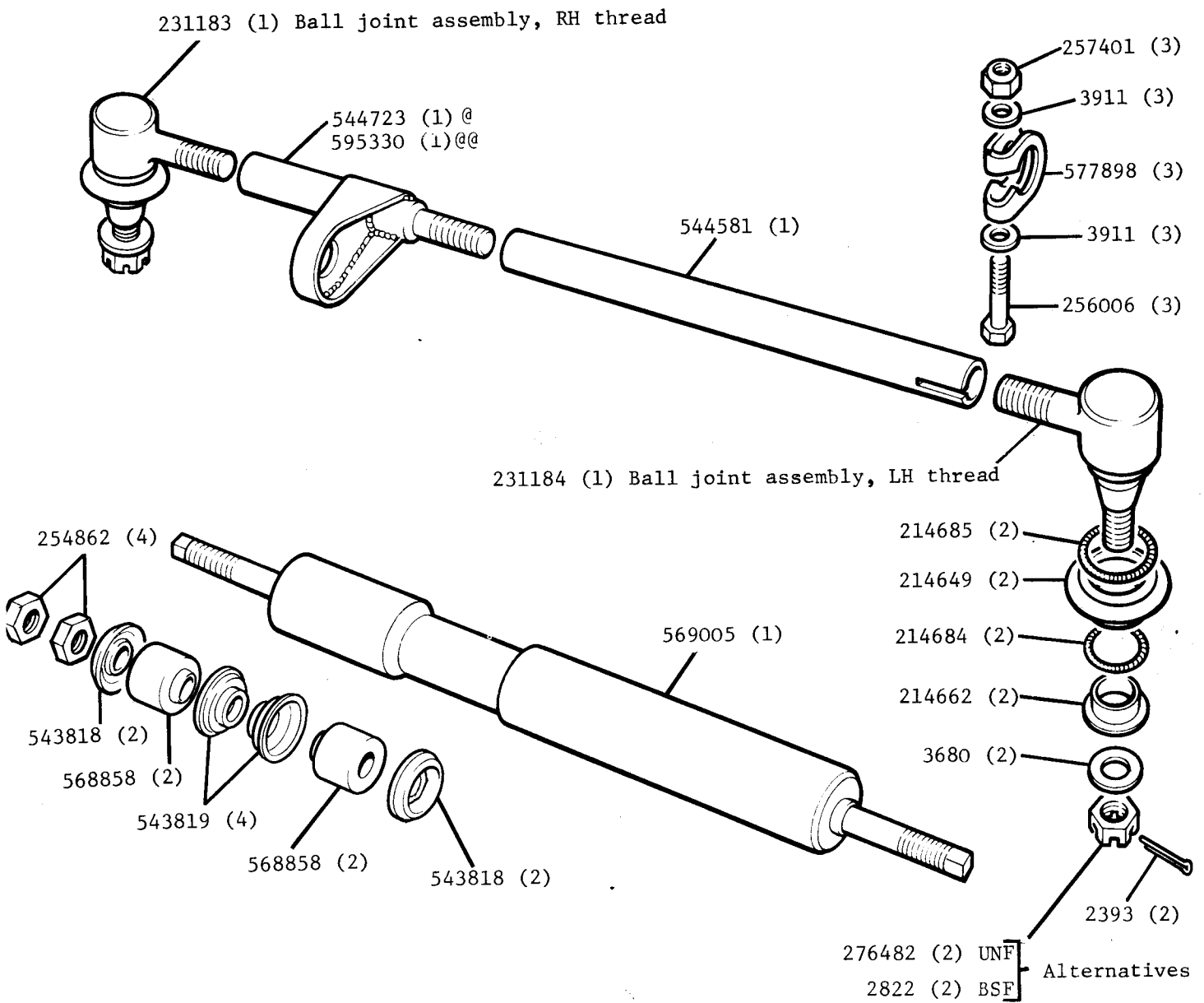

REMARKS

Steering Damper, Kit 605081 (1) @ Cannot be used in conjunction with extended shackles  
608012 (1) @@

Drag link and damper bracket assembly 569719 (1) @  
595331 (1) @@

@ Series 11A Land Rover

@@ Series 111 Land Rover

UNIVERSAL JOINT COVER PLATE SERIES IIA AND III

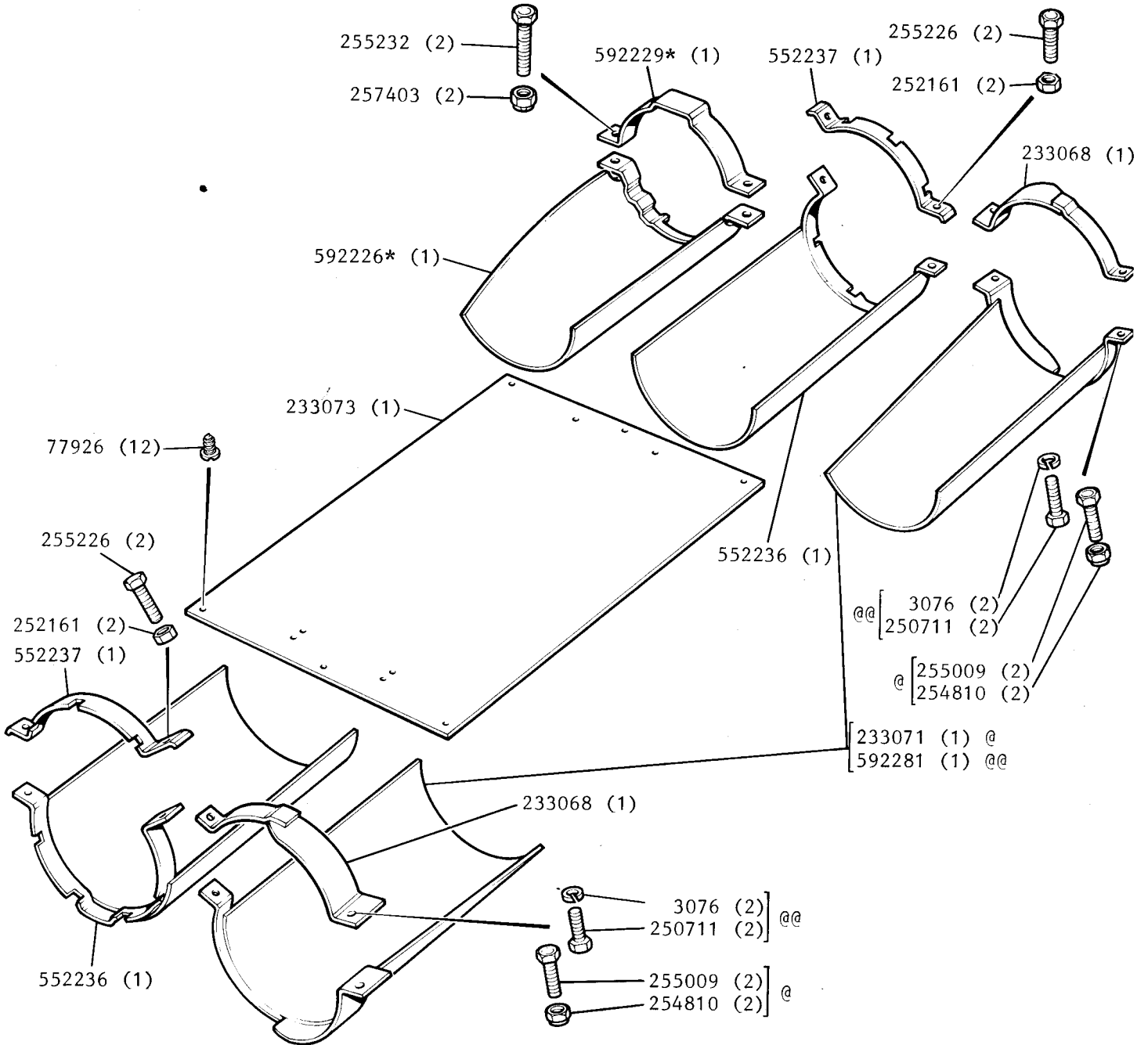

REMARKS @ Cover fixed by strap. @@ Cover fixed to housing. † Universal Joint Cover Plate Kit.

- |   |      |            |
|---|------|------------|
| † 261829 (1) 88" and 109" vehicles fitted with Rover axles front and rear                                     | ] @  | Series IIA |
| † 605930 (1) 109" vehicles fitted with an E.N.V. rear axle and Rover front axle                               |      |            |
| † 607301 (1) 109" vehicles fitted with an E.N.V rear axle and Rover front axle @@                             |      |            |
| † 601989 (1) Series IIA 109" and Series III 1 ton vehicles fitted with E.N.V. axles front and rear            |      |            |
| † 320821 (1) Series IIA and Series III 88" vehicles fitted with Rover axles front and rear                    | ] @@ |            |
| † 320822 (1) Series IIA 109" and Series III 109" vehicles fitted with Salisbury rear axle<br>Rover front axle |      |            |

HEAVY DUTY SHOCK ABSORBERS, SERIES IIA AND III

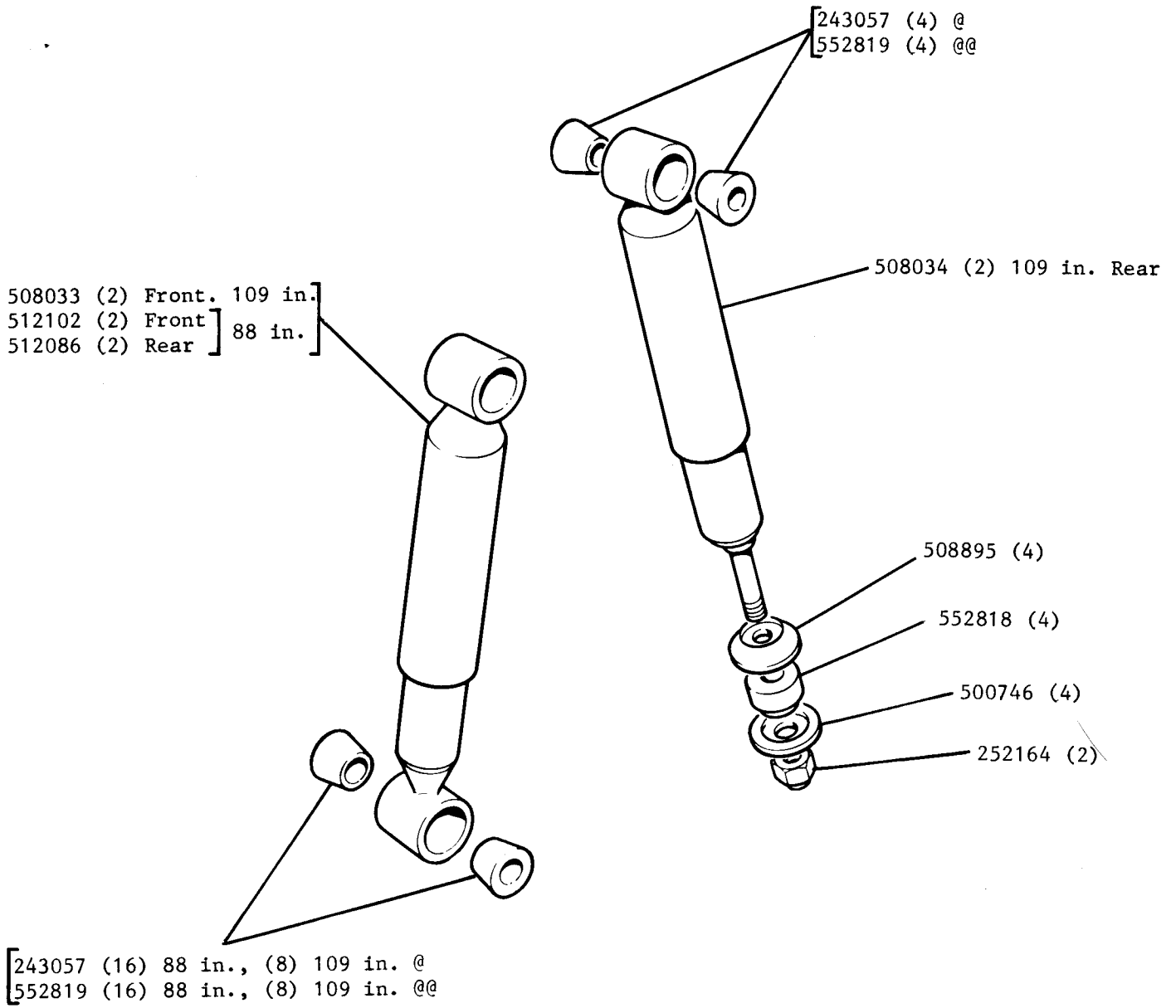

REMARKS

@ Except Angola January 1973 onwards

@@ Angola only January 1973 onwards

HEAVY DUTY ROAD SPRINGS, SERIES IIA AND III

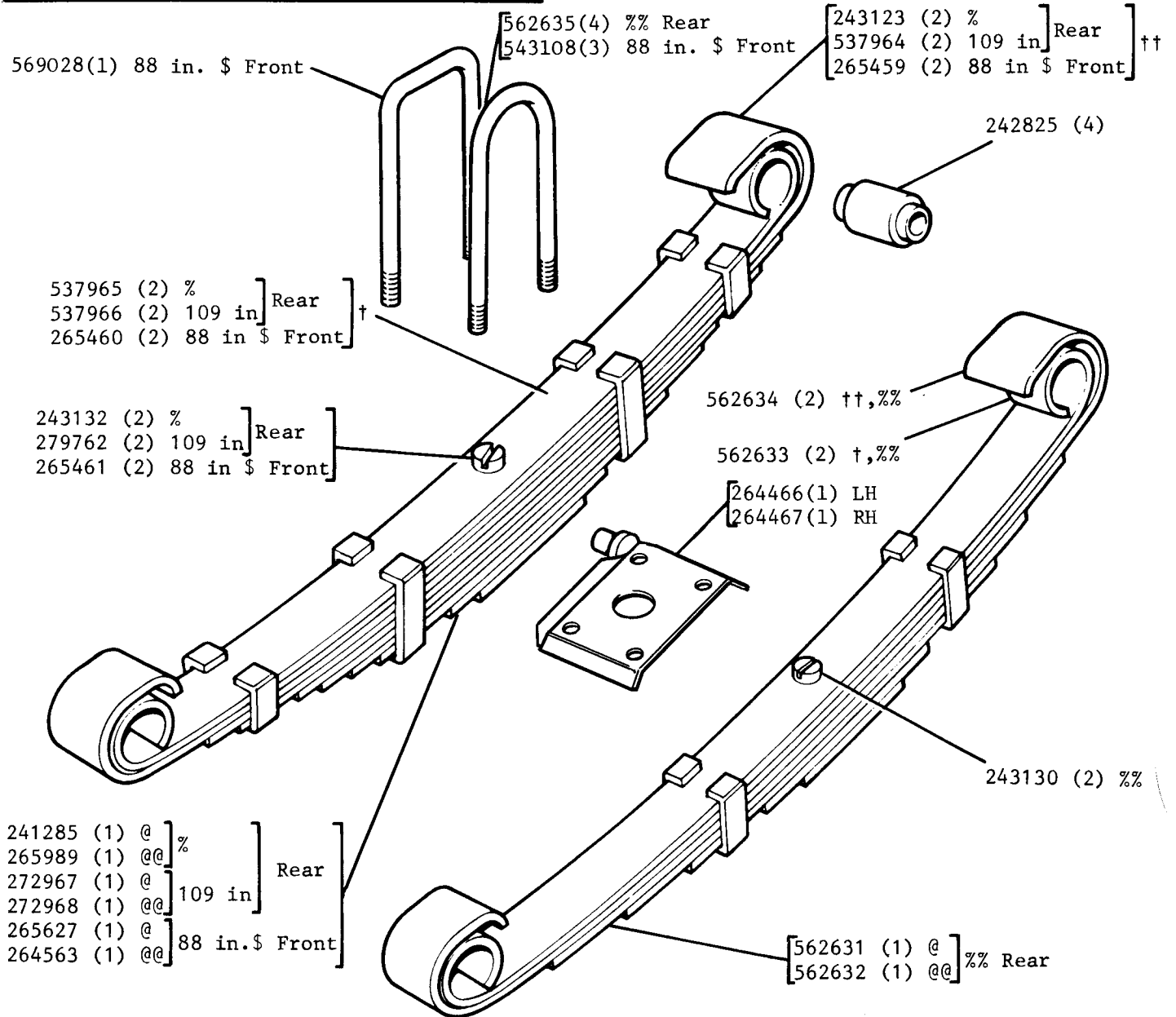

REMARKS

- @ Driver side spring assembly
- @@ Passenger side spring assembly
- † Main leaf
- †† Second leaf
- % Series IIA 88 in.
- %% Series III 88 in.
- \$ Used in conjunction with a hydraulic winch

BRAKE MASTER CYLINDER AND SERVO. SERIES III 109" 2½ LITRE MODELS

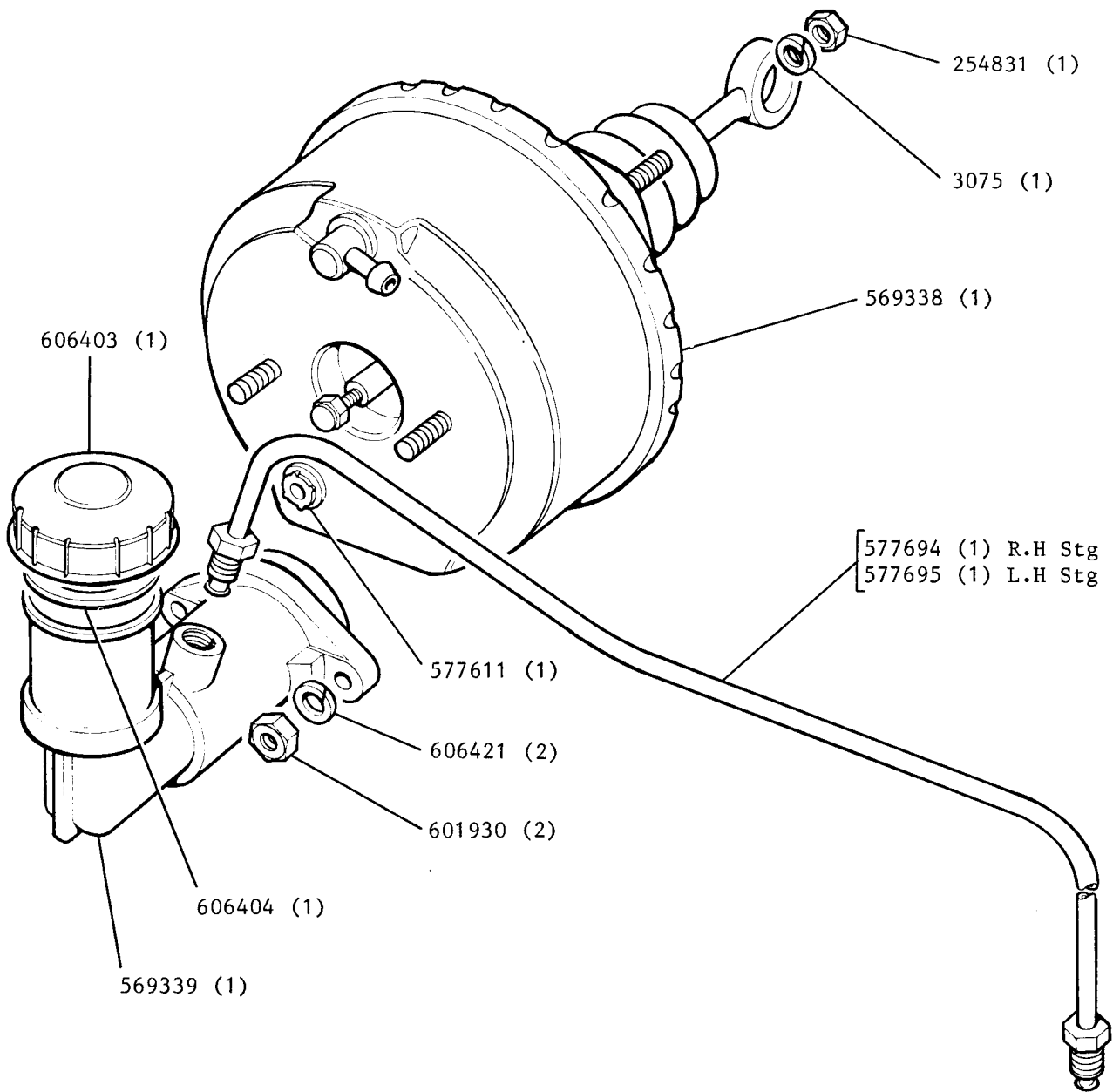

REMARKS

Brake Master Cylinder Overhaul Kit 606415 (1)

BRAKE PEDAL AND BRACKET, VEHICLES WITH SERVO

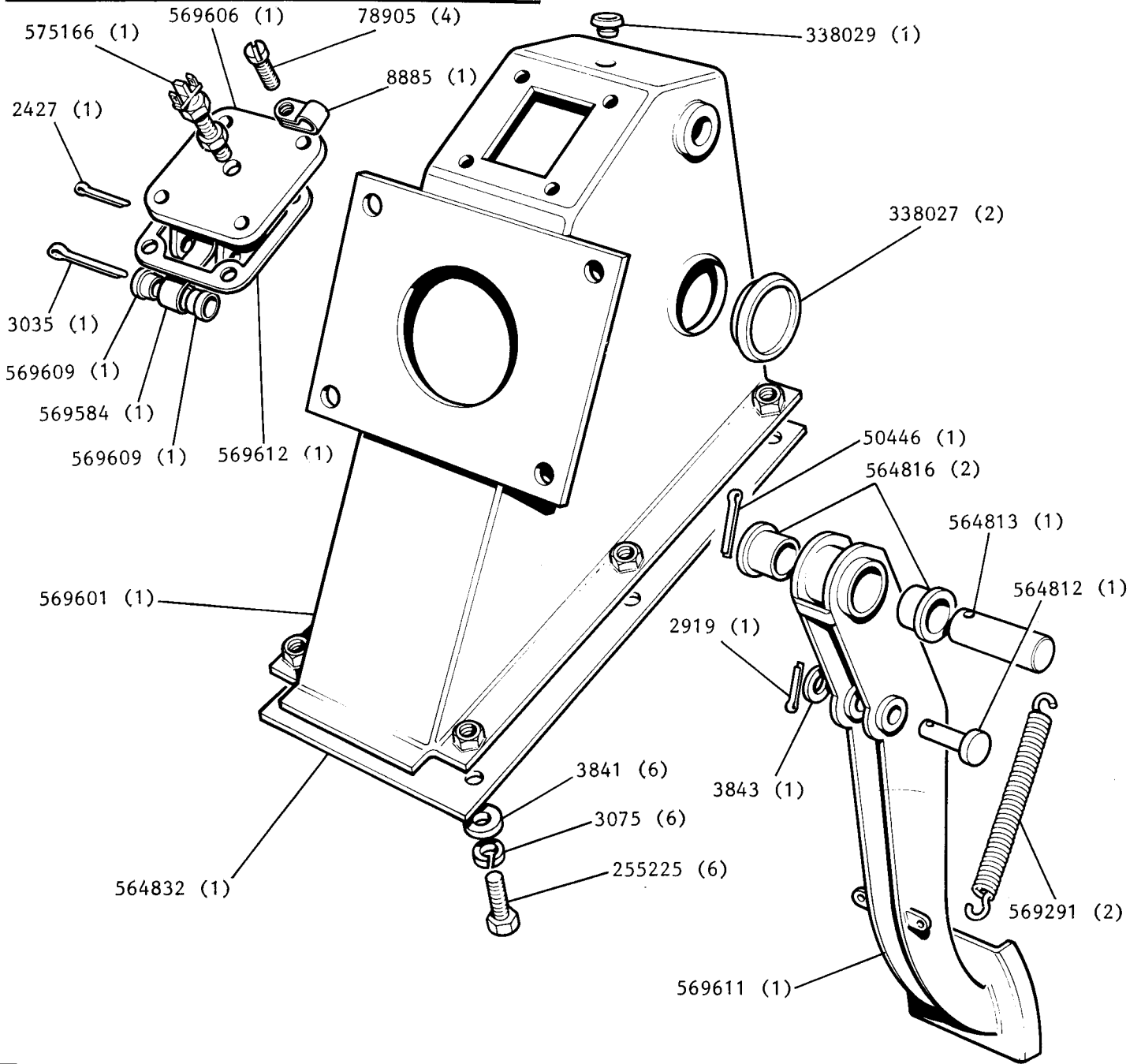

REMARKS

Brake pedal and bracket assembly 569652 (1)



BRAKE SERVO VACUUM SYSTEM THROTTLE BODY, INLET MANIFOLD AND OPERATING LEVERS. SERIES III DIESEL

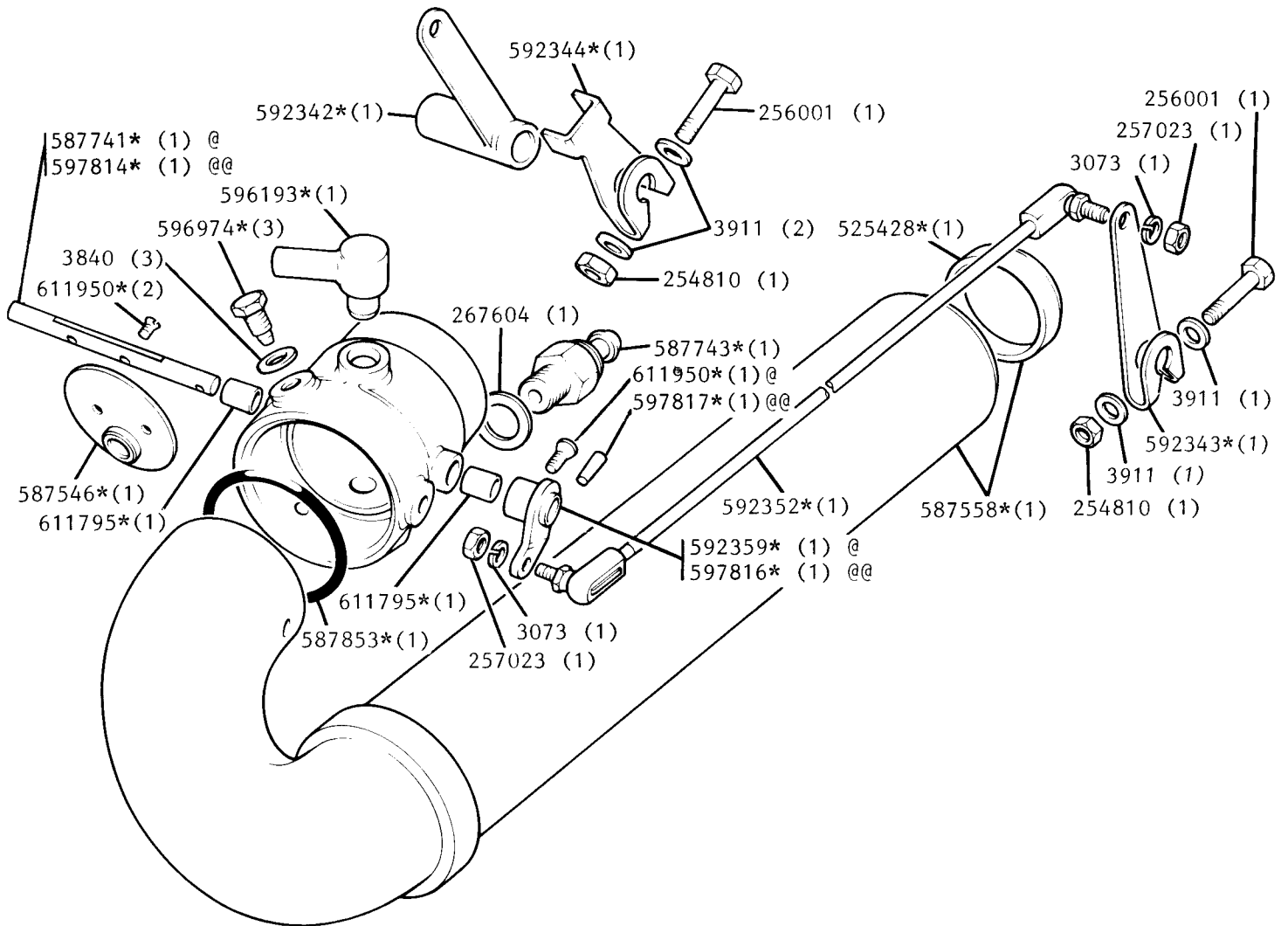

REMARKS

Throttle Body Complete Assembly 596253\*(1) @  
 Throttle Body Complete Assembly 597815\* (1) @@  
 @ Screw fixing  
 @@ Taper pin fixing

BRAKE SERVO VACUUM SYSTEM PIPES AND VACUUM TANK SERIES III  
WITH VACUUM TANK MOUNTED ON L.H. FRONT WING VALANCE

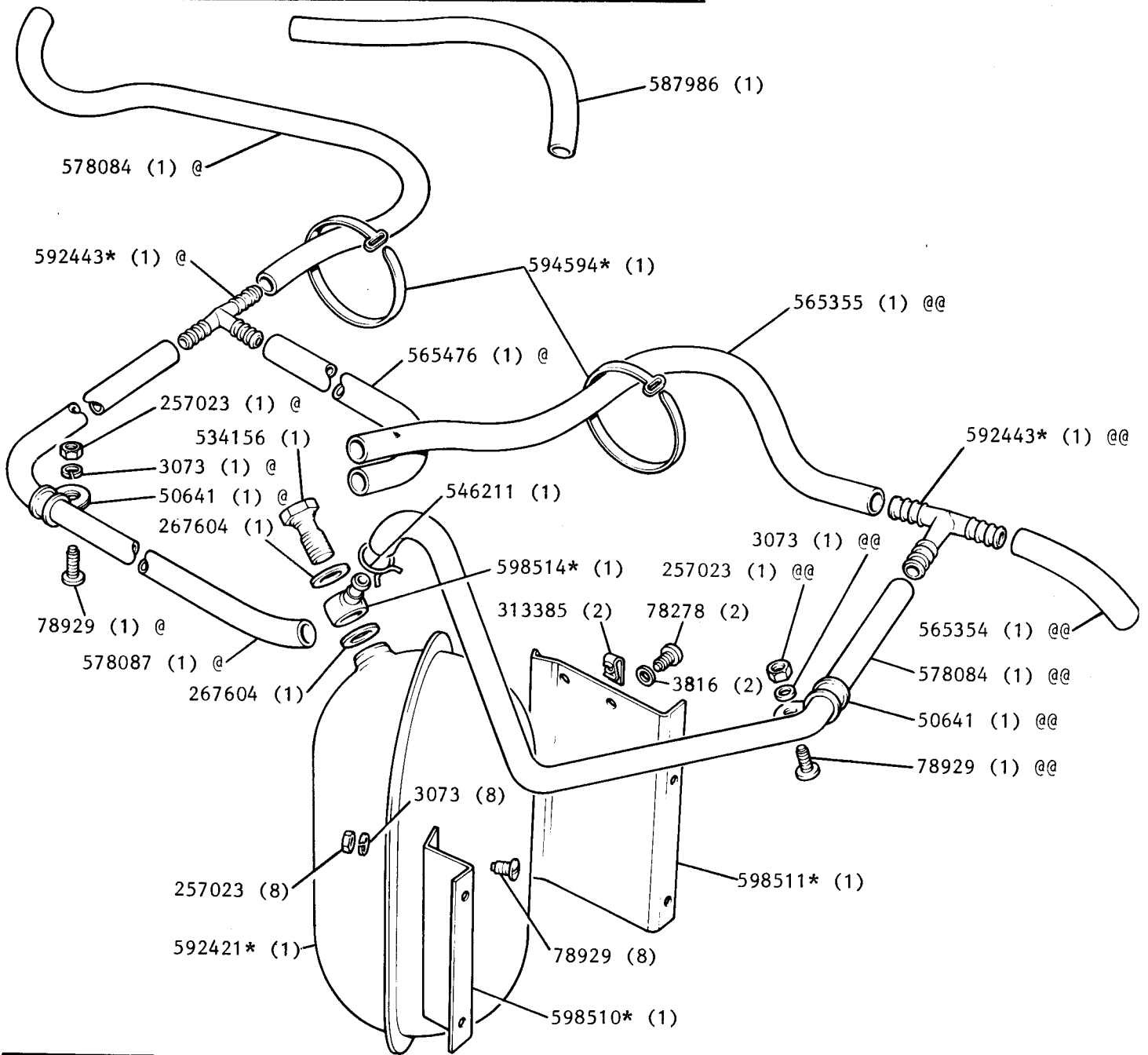

REMARKS

@ R.H. Stg  
@@ L.H. Stg

BRAKE SERVO VACUUM SYSTEM PIPES AND VACUUM TANK

SERIES III WITH VACUUM TANK MOUNTED UNDER THE PASSENGER SEAT.

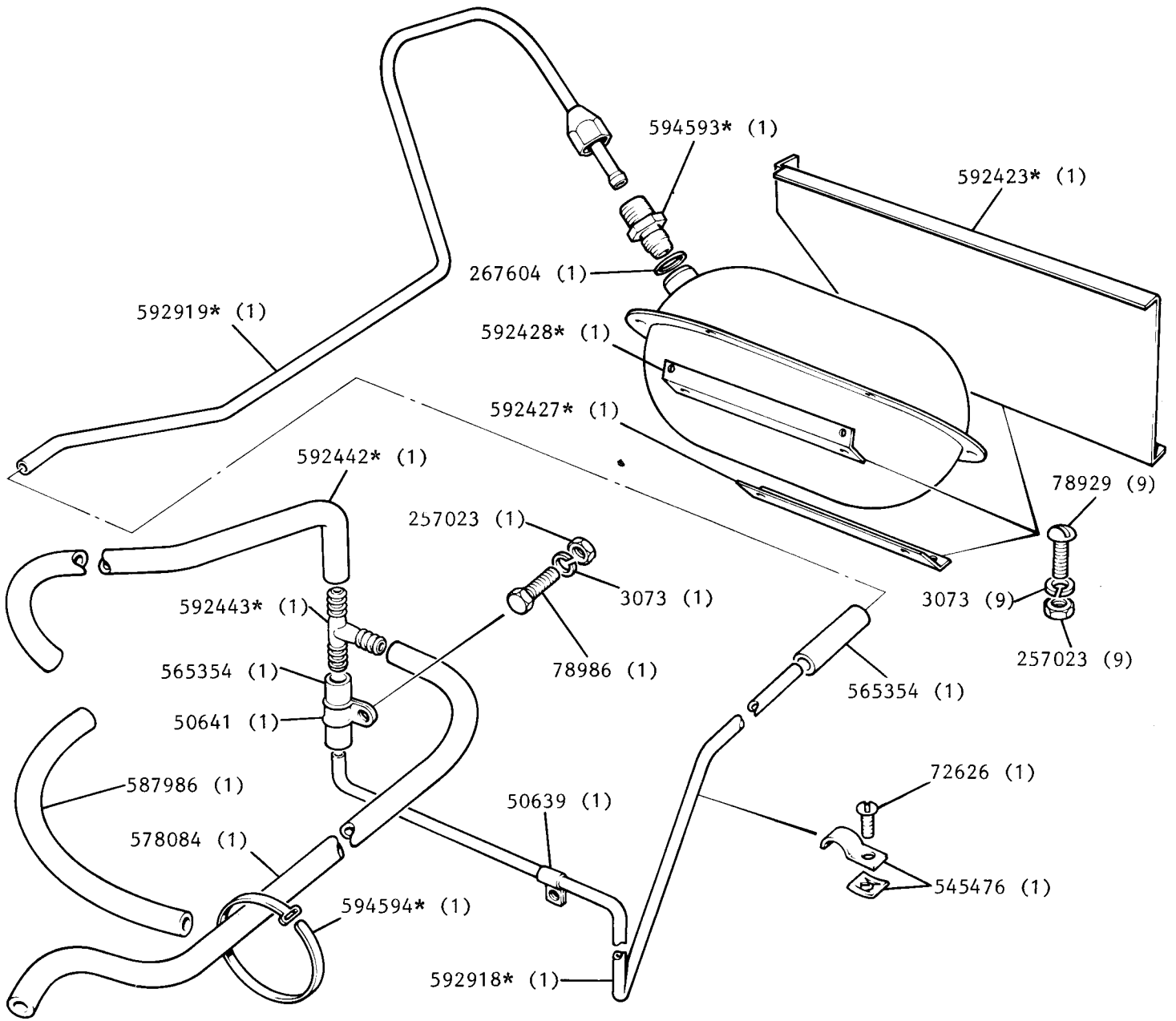

REMARKS

VACUUM SYSTEM SERIES III PETROL MODELS

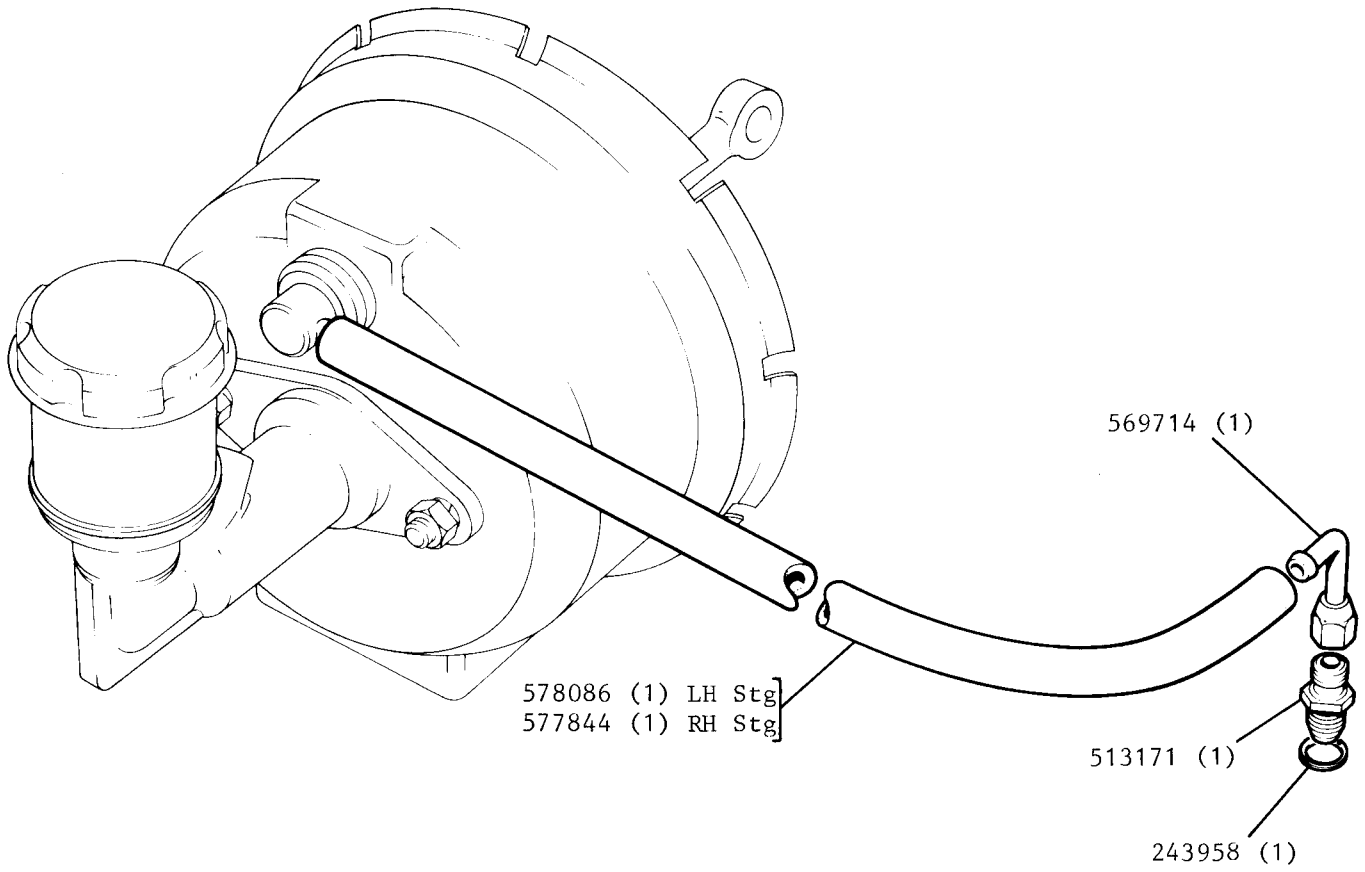

---

REMARKS

BRAKE VACUUM WARNING LOSS SERIES III 109 in.

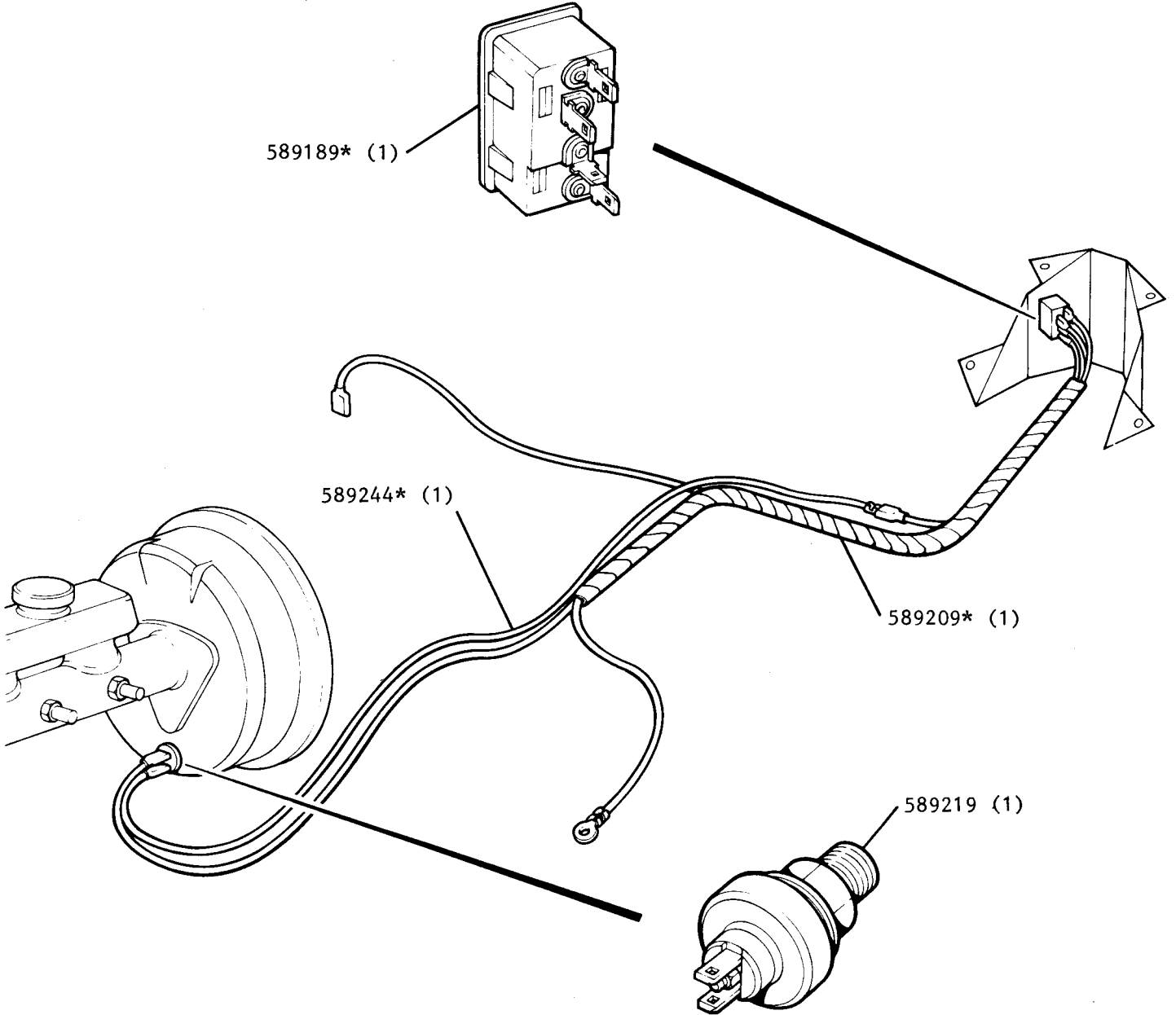

---

REMARKS

**TUBING, JETS, WIPER MOTOR, INSTRUMENT PANEL AND FIXINGS FOR TWO SPEED WIPER AND WASHER, SERIES IIA SWEDISH VEHICLES FROM VEHICLE SUFFIX G ONWARDS AND SERIES III**

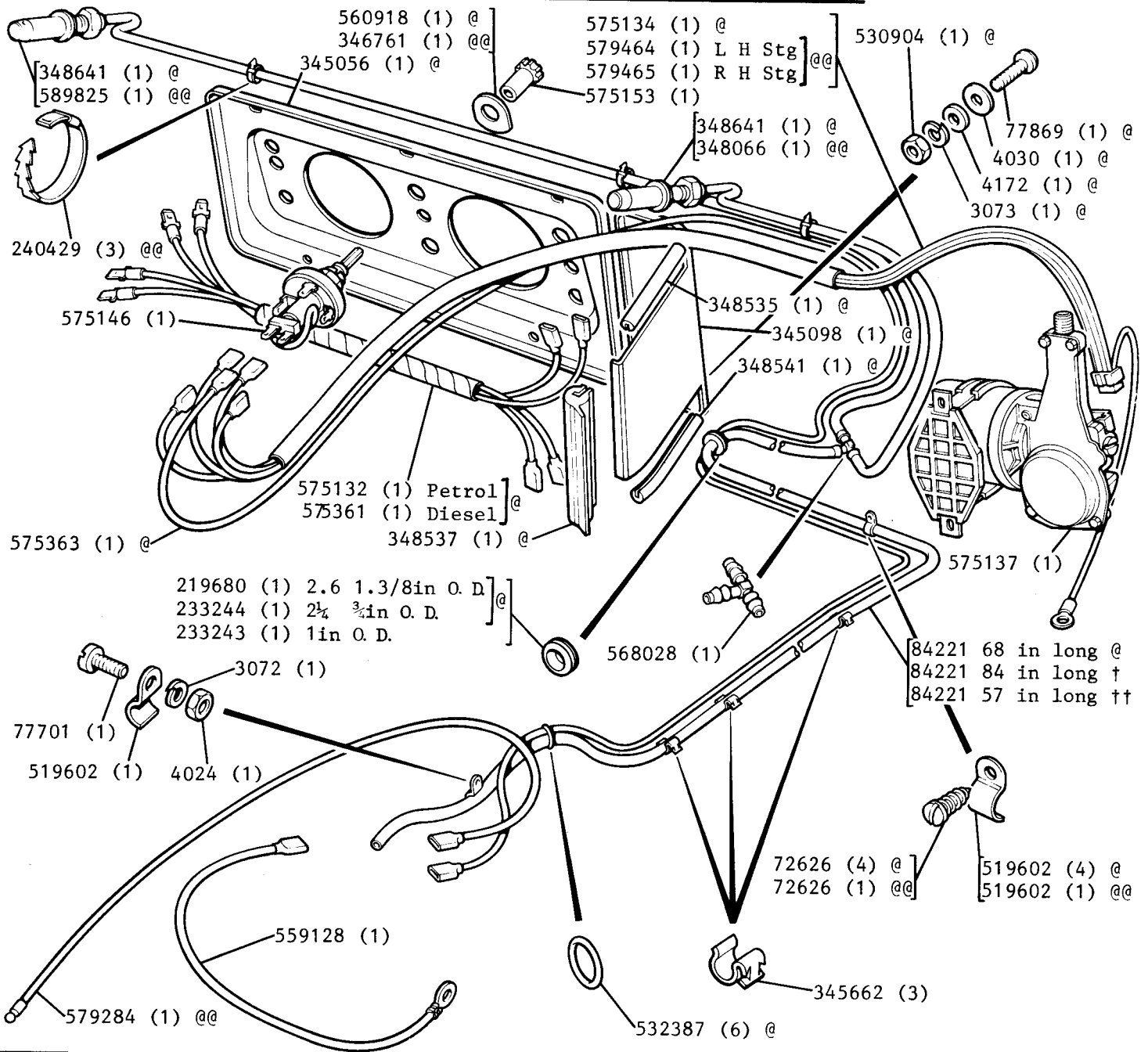

**REMARKS**

- @ Series IIA Swedish vehicles from vehicle suffix G onwards
- @@ Series III
- † Series III up to July 1972 inclusive
- †† From August 1972 onwards

TUBING, JETS AND FIXINGS FOR WINDSCREEN WASHER, ELECTRIC, SERIES IIA FROM JULY 1969 AND SERIES III.

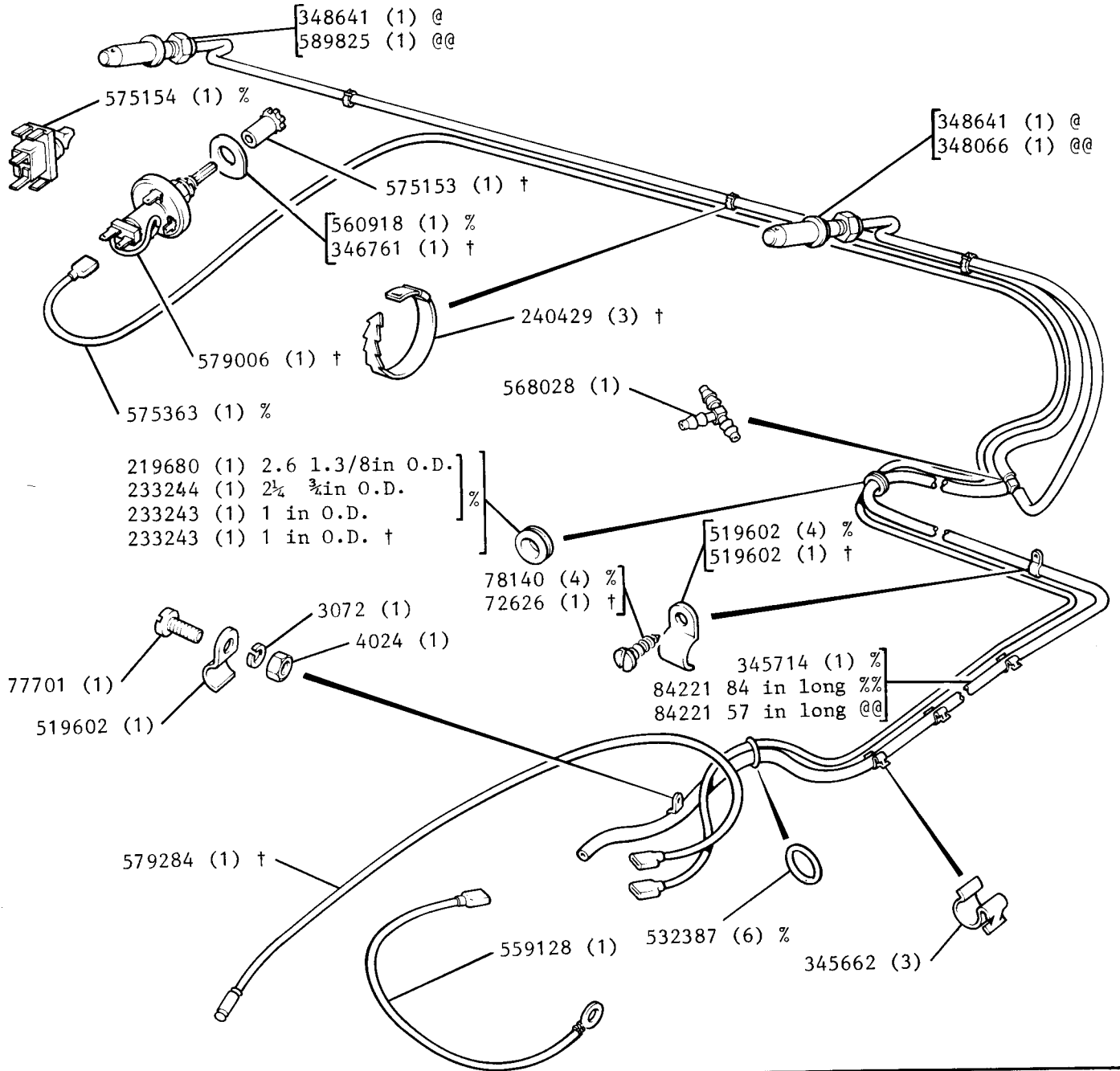

REMARKS

- @ Up to July 1972 inclusive
- @@ From August 1972 onwards
- % Series IIA
- %% Series III up to July 1972 inclusive
- † Series III

TUBING, JETS AND FIXINGS FOR WINDSCREEN WASHER MANUAL, SERIES IIA

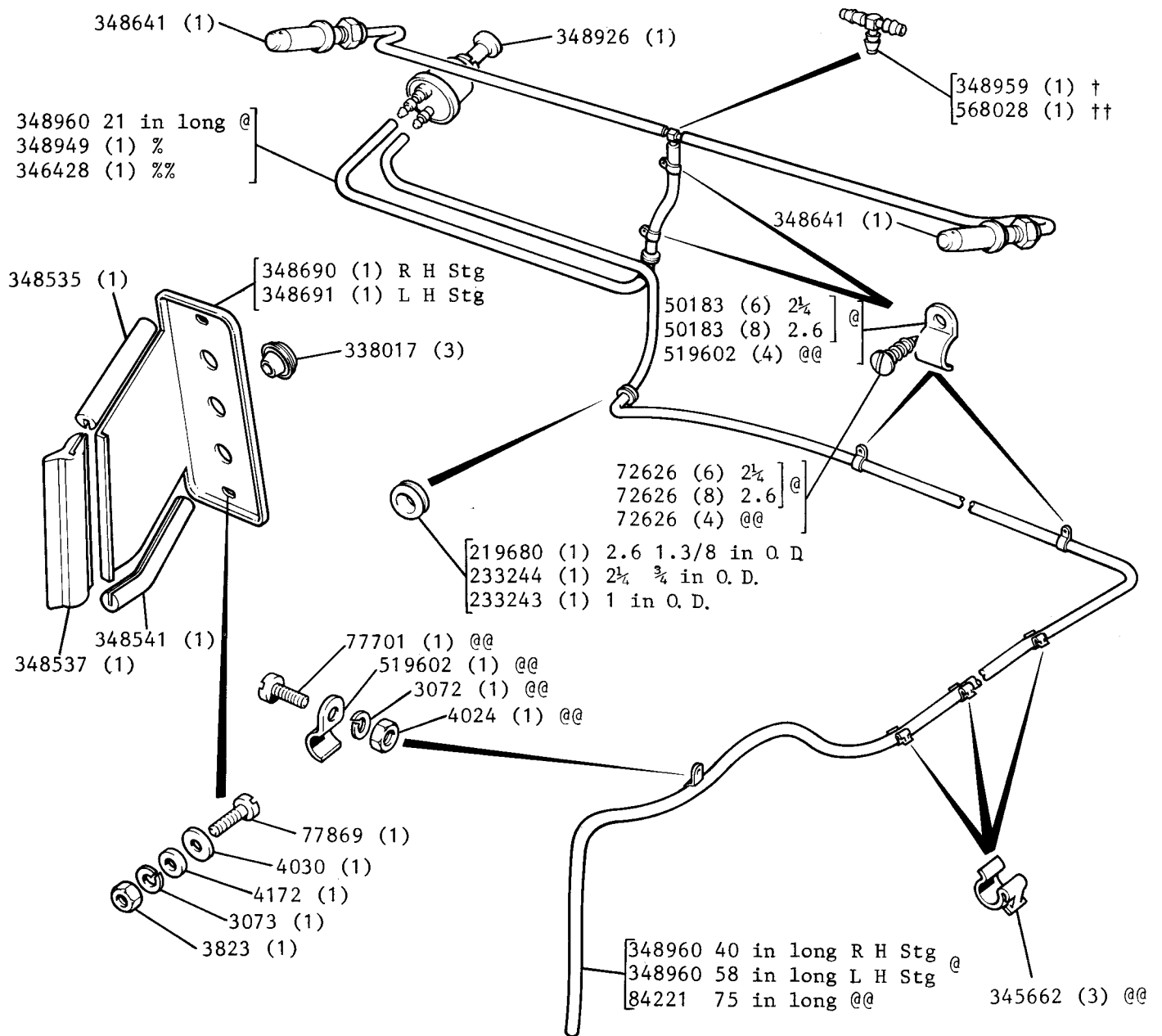

REMARKS

- † Three equal diameter outlets
- †† Two equal diameter outlets
- @ Up to vehicle suffix F inclusive
- @@ From vehicle suffix G onwards
- % From vehicle suffix G to 5th July 1970
- %% From 6th July 1970 onwards



WASHER BOTTLE FOR MANUAL SCREEN WASHER SERIES IIA

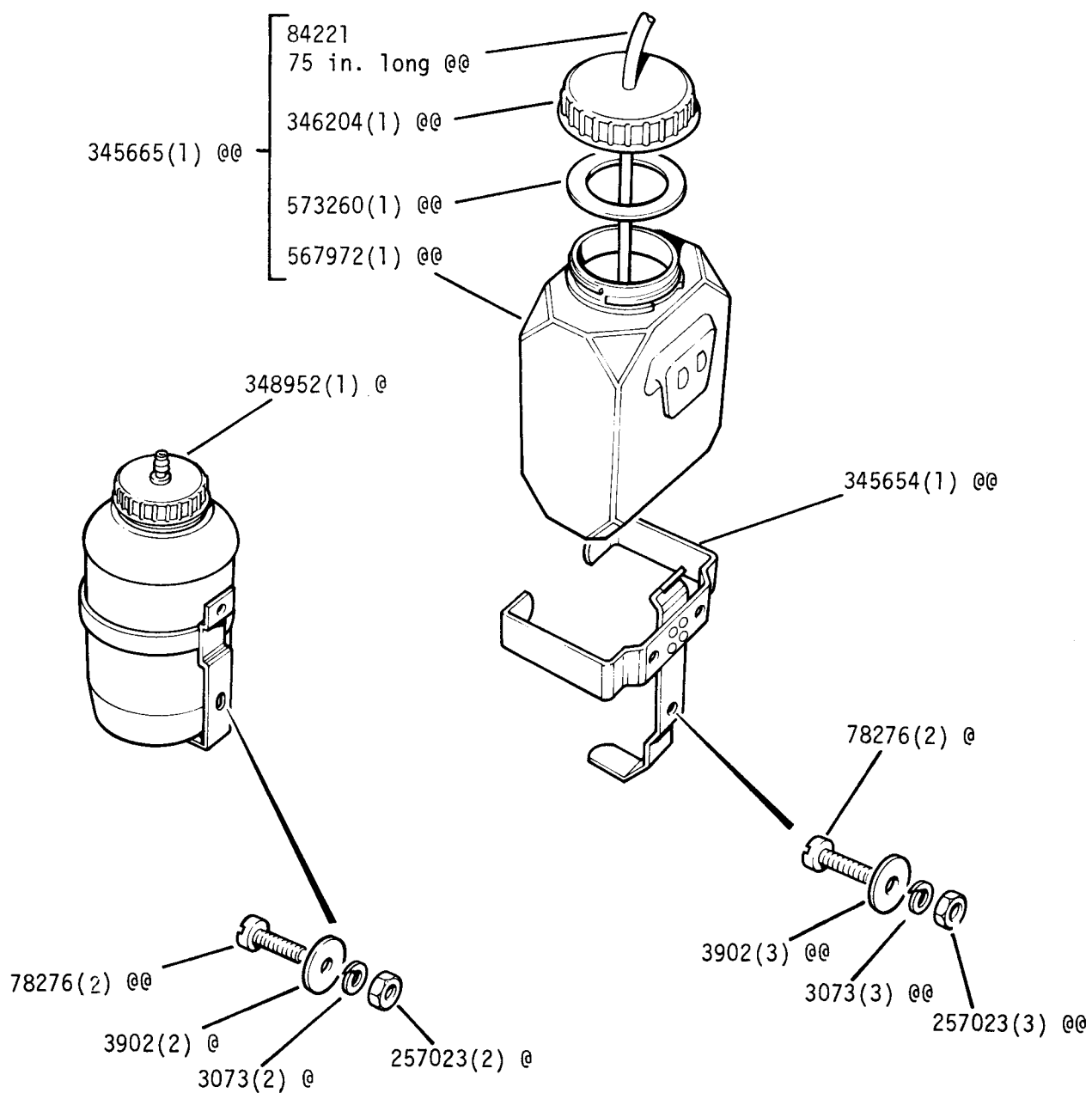

REMARKS

@ Up to vehicle suffix F inclusive  
 @@ From vehicle suffix G onwards

WASHER BOTTLE AND PUMP FOR ELECTRIC SCREEN WASHER SERIES IIA AND III

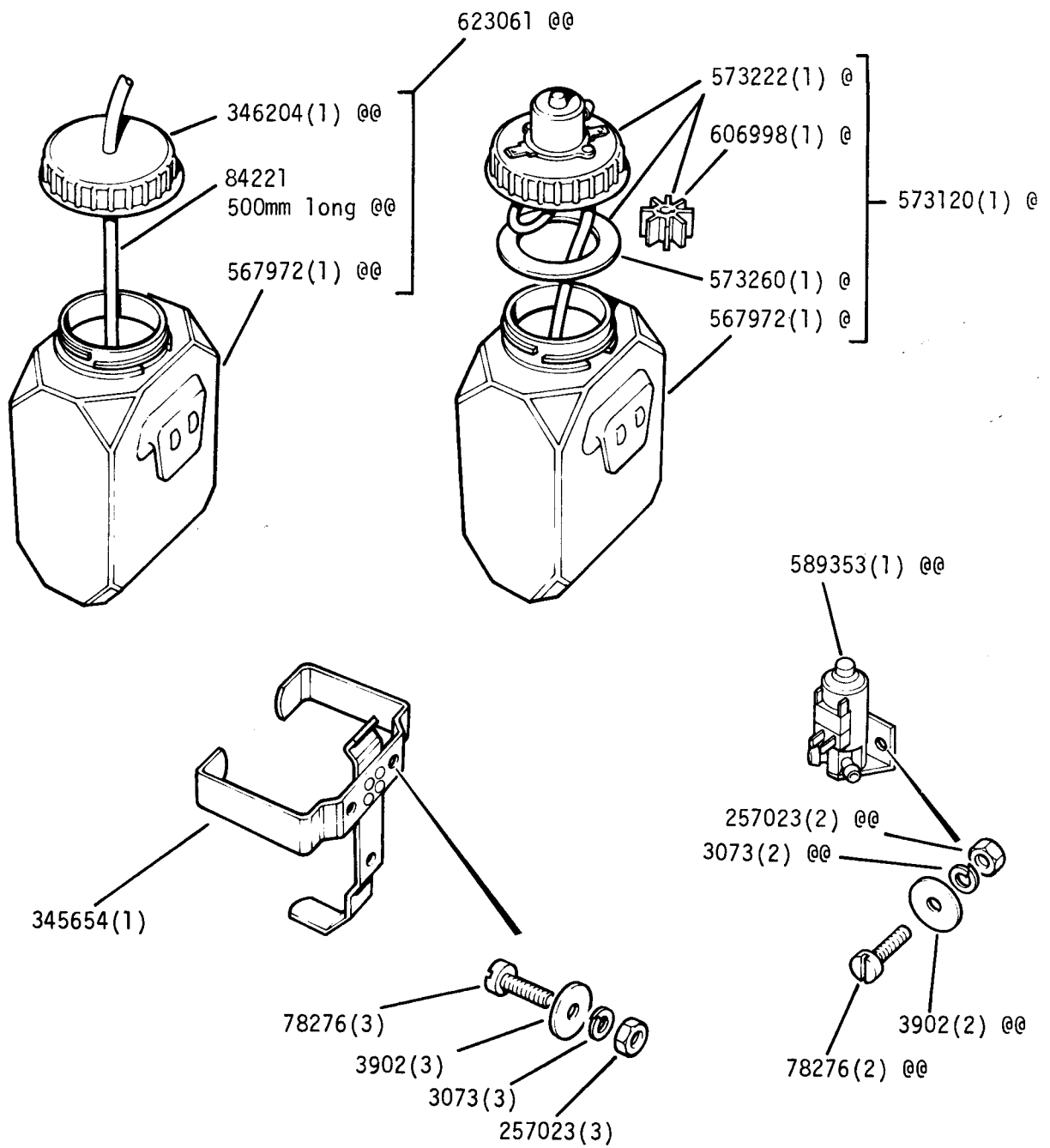

REMARKS

- @ Pump on washer bottle cap
- @@ Pump on LH wing valance

AUXILIARY INSTRUMENT PANEL SERIES IIA

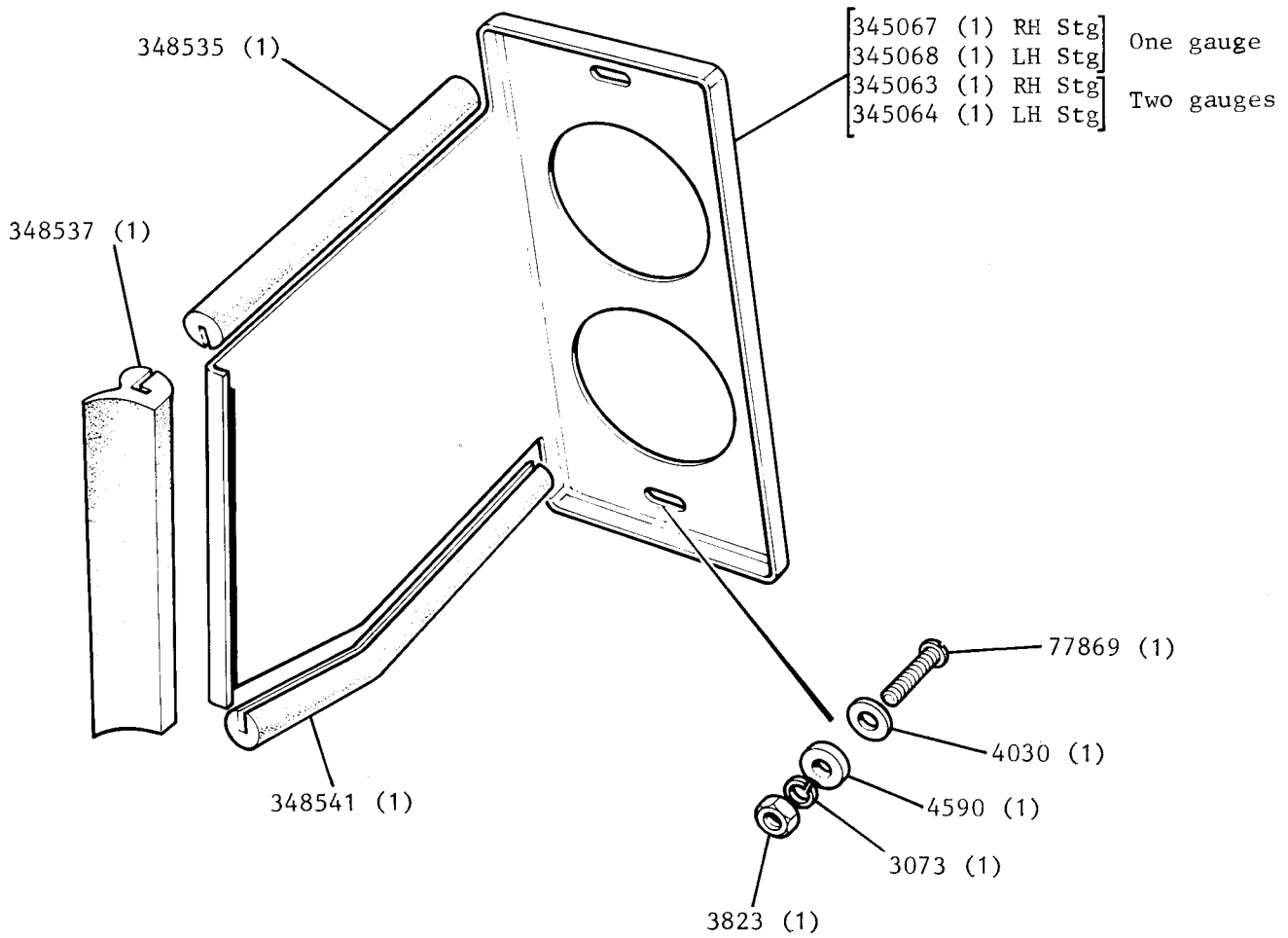

---

REMARKS

AUXILIARY SWITCH PANEL AND AUXILIARY INSTRUMENT COVER PANEL      SERIES III

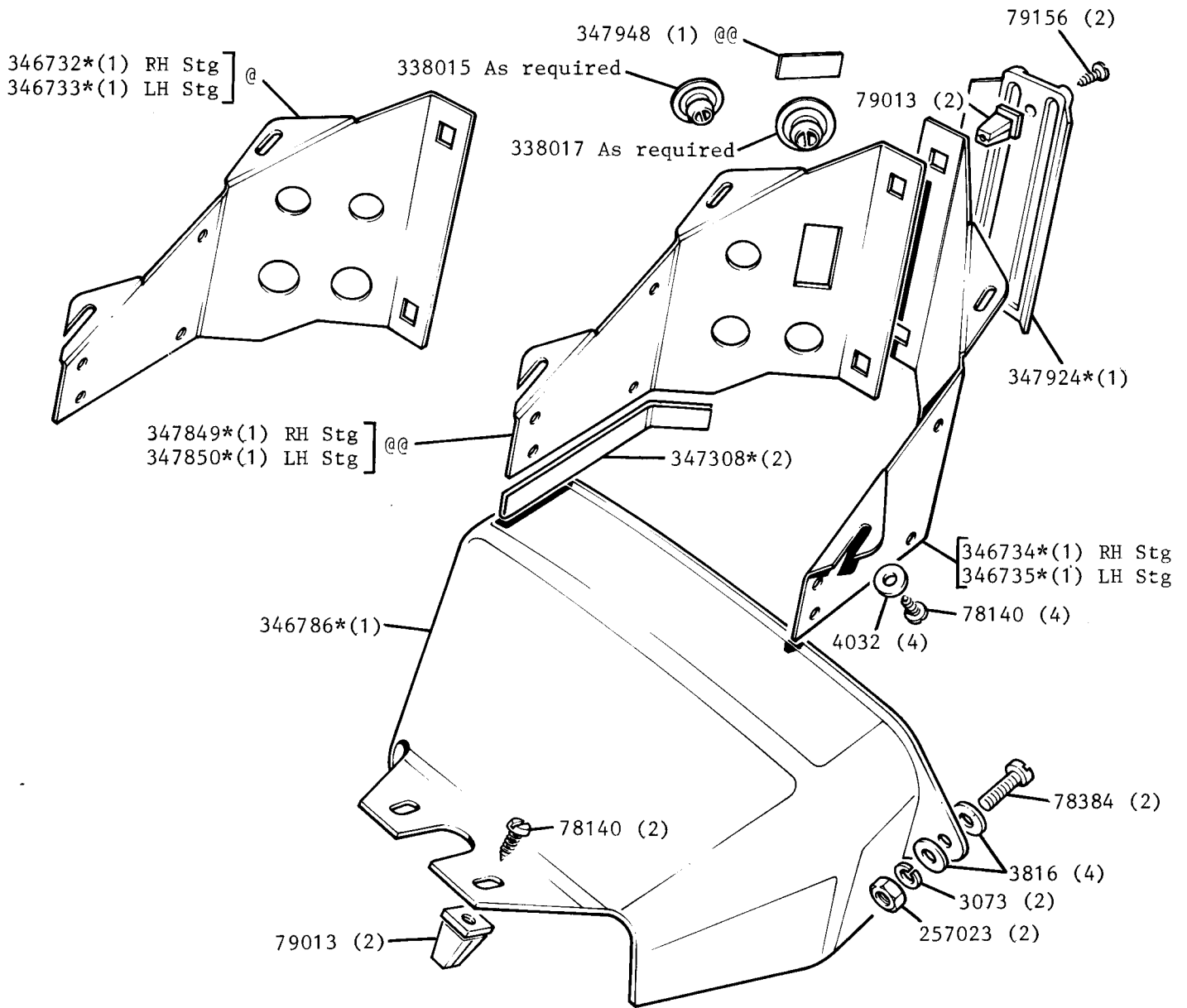

REMARKS

@ Part of Kits 320837\*, 320838\* only

@@ Part of Kits 320843\*, 320844\* only

Auxiliary Switch Panel Kit 320837\*(1) RH Stg

Auxiliary Switch Panel Kit 320838\*(1) LH Stg

Brake Failure Warning Light and Switch Panel Kit 320843\*(1) RH Stg

Brake Failure Warning Light and Switch Panel Kit 320844\*(1) LH Stg

Cover Panel Kit 320835\*(1)

Use in conjunction with kits 320840\*, 320841\*, 320865\* or 320866 when provision for an extra gauge is required

AUXILIARY SWITCH AND INSTRUMENT PANEL SERIES III

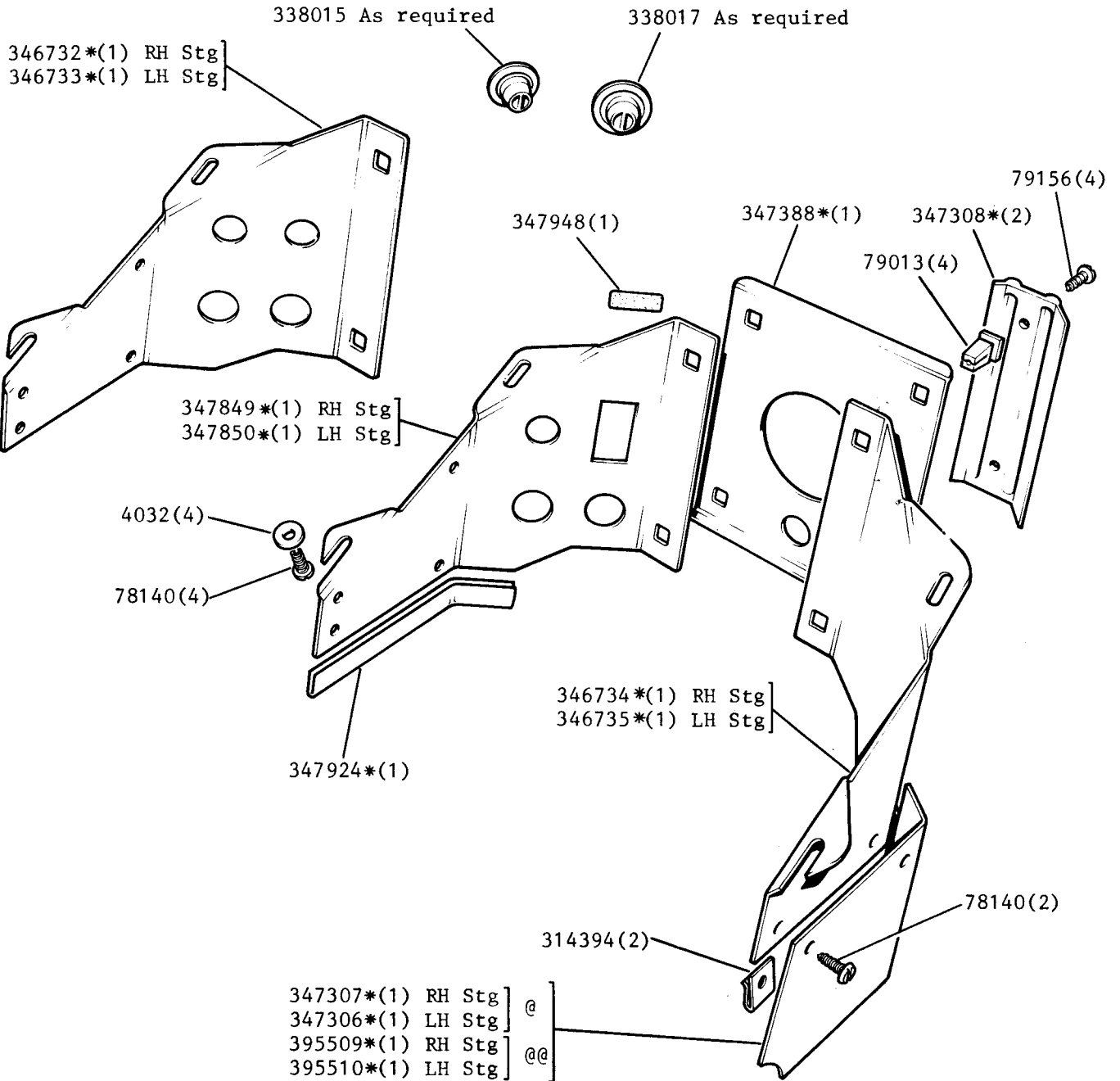

REMARKS

@ Up to June 1972 inclusive  
 @@ From July 1972 onwards

- |  |    |   |
|--|----|---|
| Auxiliary Instrument Panel Kit 320840*(1) RH Stg | @  | ] Must be used in conjunction with one of the following kits. 320837, 320838, 320843 and 320844 |
| Auxiliary Instrument Panel Kit 320841*(1) LH Stg | @  |   |
| Auxiliary Instrument Panel Kit 320865*(1) RH Stg | @@ |   |
| Auxiliary Instrument Panel Kit 320866*(1) LH Stg | @@ |   |

SPEEDOMETERS. SERIES IIA AND III

579468 (1) \$

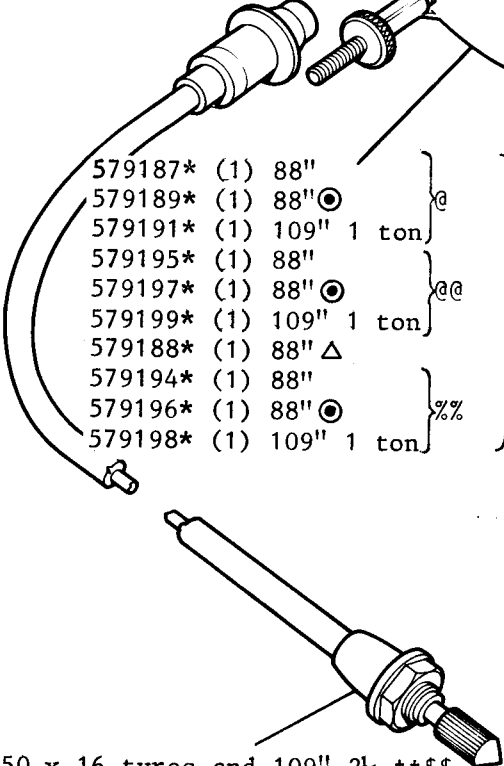
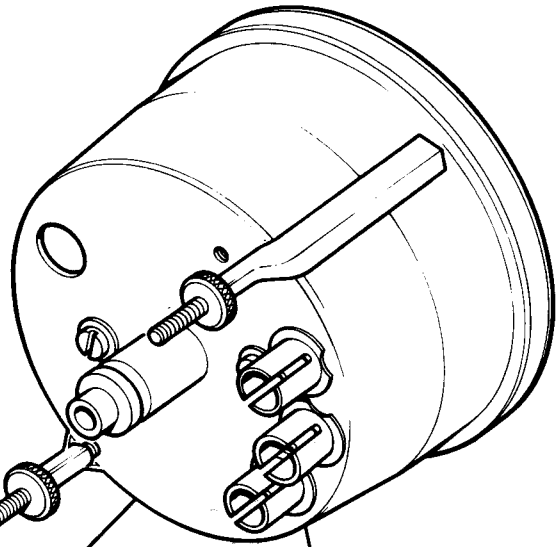
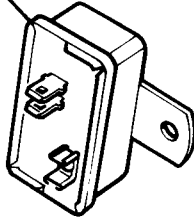
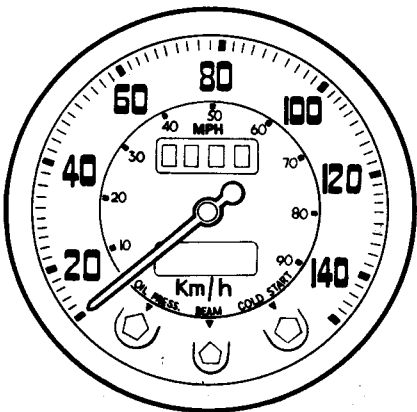
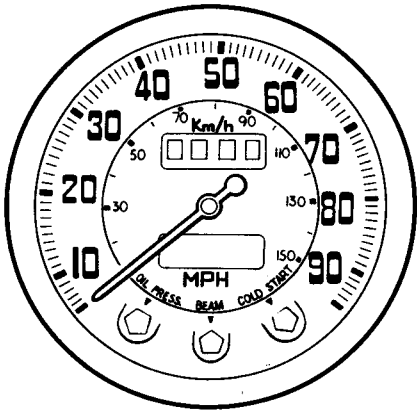

- 579187\* (1) 88" } @
- 579189\* (1) 88" ⊙ } @
- 579191\* (1) 109" 1 ton } @
- 579195\* (1) 88" } @@
- 579197\* (1) 88" ⊙ } @@
- 579199\* (1) 109" 1 ton } @@
- 579188\* (1) 88" Δ } %
- 579194\* (1) 88" } %
- 579196\* (1) 88" ⊙ } %
- 579198\* (1) 109" 1 ton } %

- \$ 239565 (1) 88" } @
- 279341 (1) 88" ⊕ } @
- 240427 (1) 88" } @@
- 279343 (1) 88" ⊕ } @@ †
- 279340 (1) 88" Δ } †
- 240426 (1) 88" } %
- 279342 (1) 88" ⊕ } %
- 540115 (1) 88" } @
- 540118 (1) 88" ⊕ } @
- 540133 (1) 88" } @@ ††
- 540134 (1) 88" ⊕ } @@ ††
- 540117 (1) 88" Δ } ††
- 540129 (1) 88" } %
- 540130 (1) 88" ⊕ } %
- 559160 (1) @ } \$
- 559165 (1) @@ } 109" 2.6
- 559164 (1) % } \$

540128 (1) 88", 88" fitted with 750 x 16 tyres and 109" 2¼ ††\$  
 579172\* (1) \$

REMARKS

- \$ Series III
- \$\$ Series IIA
- † Up to vehicle suffix C inclusive
- †† From vehicle suffix D onwards
- @ K.P.H. no trip
- @@ K.P.H. with trip
- % M.P.H. no trip
- %% M.P.H. with trip

- Δ Fitted with 750 x 16 tyres %
- ⊙ Fitted with 750 x 16 tyres and 109"
- ⊕ Fitted with 750 x 16 tyres and 109" 2¼

FRESH AIR HEATER BLOWER, BOX AND WING. SERIES III

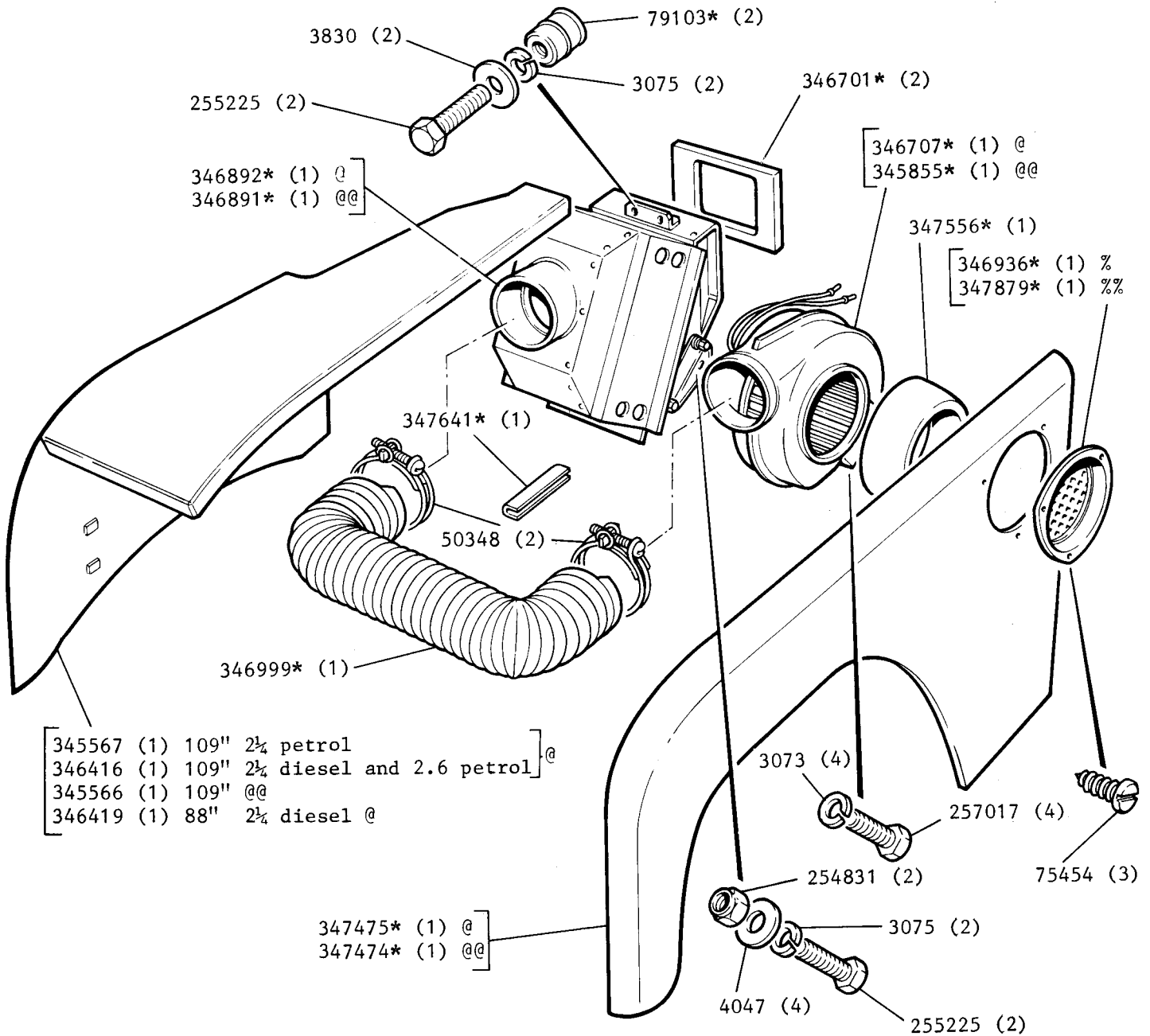

REMARKS

@ R.H.Stg

@@ L.H.Stg

% Except German Market

%% German Market only

FRESH AIR HEATER PIPES, HOSES AND WATER VALVE SERIES III 2½ MODELS

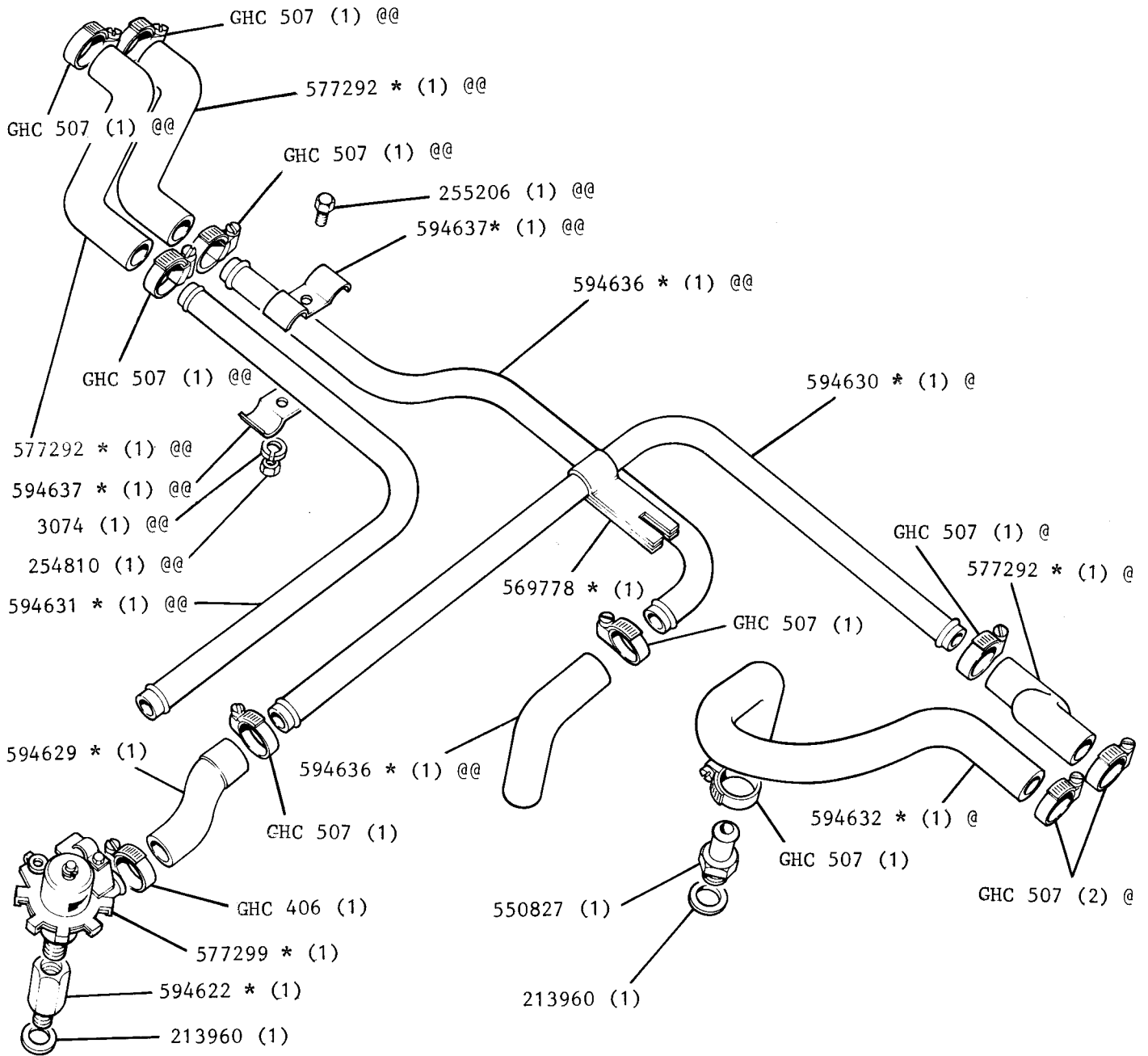

REMARKS

@ RH Stg  
 @@ LH Stg



FRESH AIR HEATER PIPES, HOSES AND WATER VALVE SERIES III 2.6 MODELS

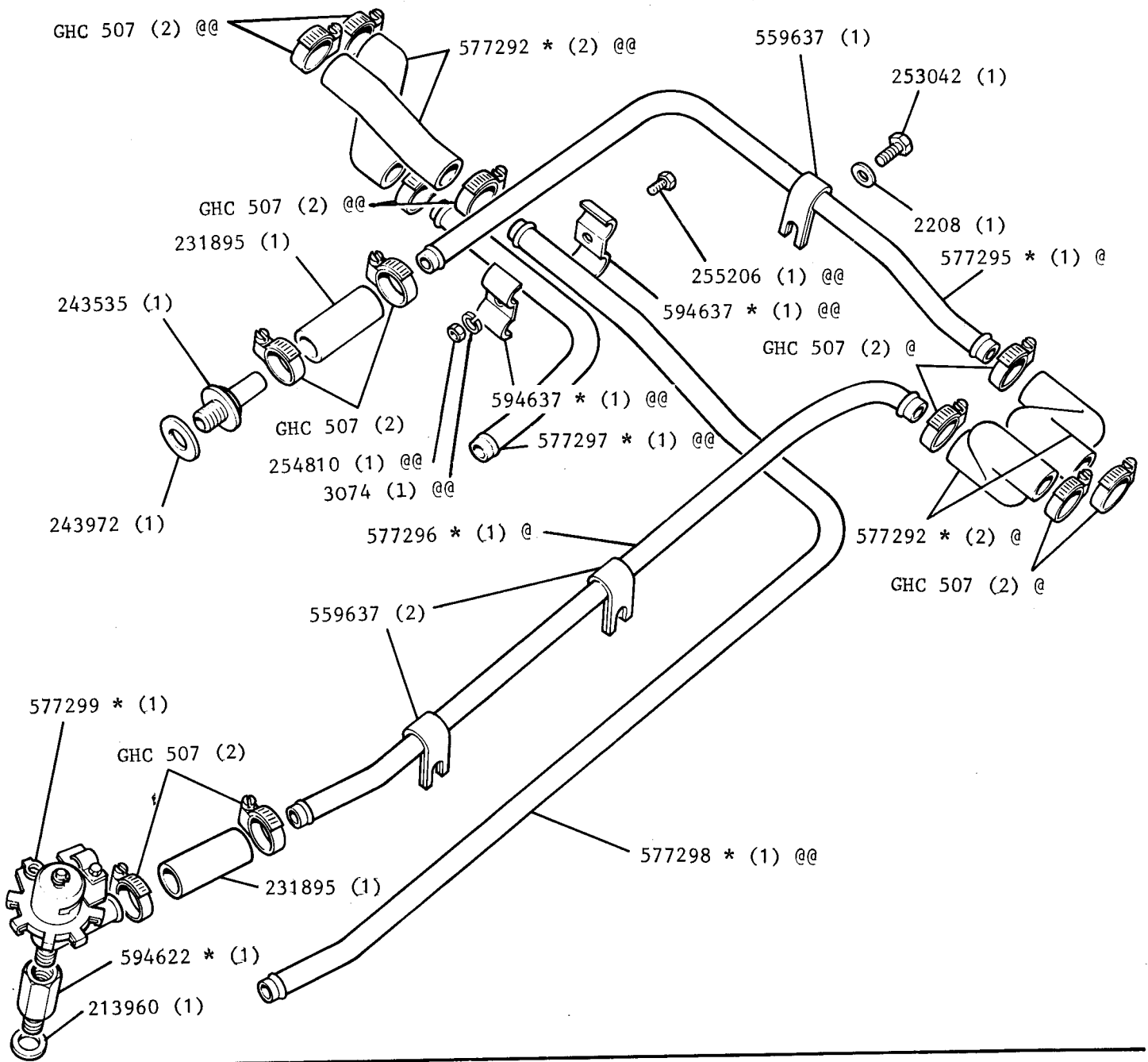

REMARKS

@ RH Stg  
 @@ LH Stg

FRESH AIR HEATER CONTROLS, OUTLET FLAPS AND DEMISTERS SERIES III

25 46

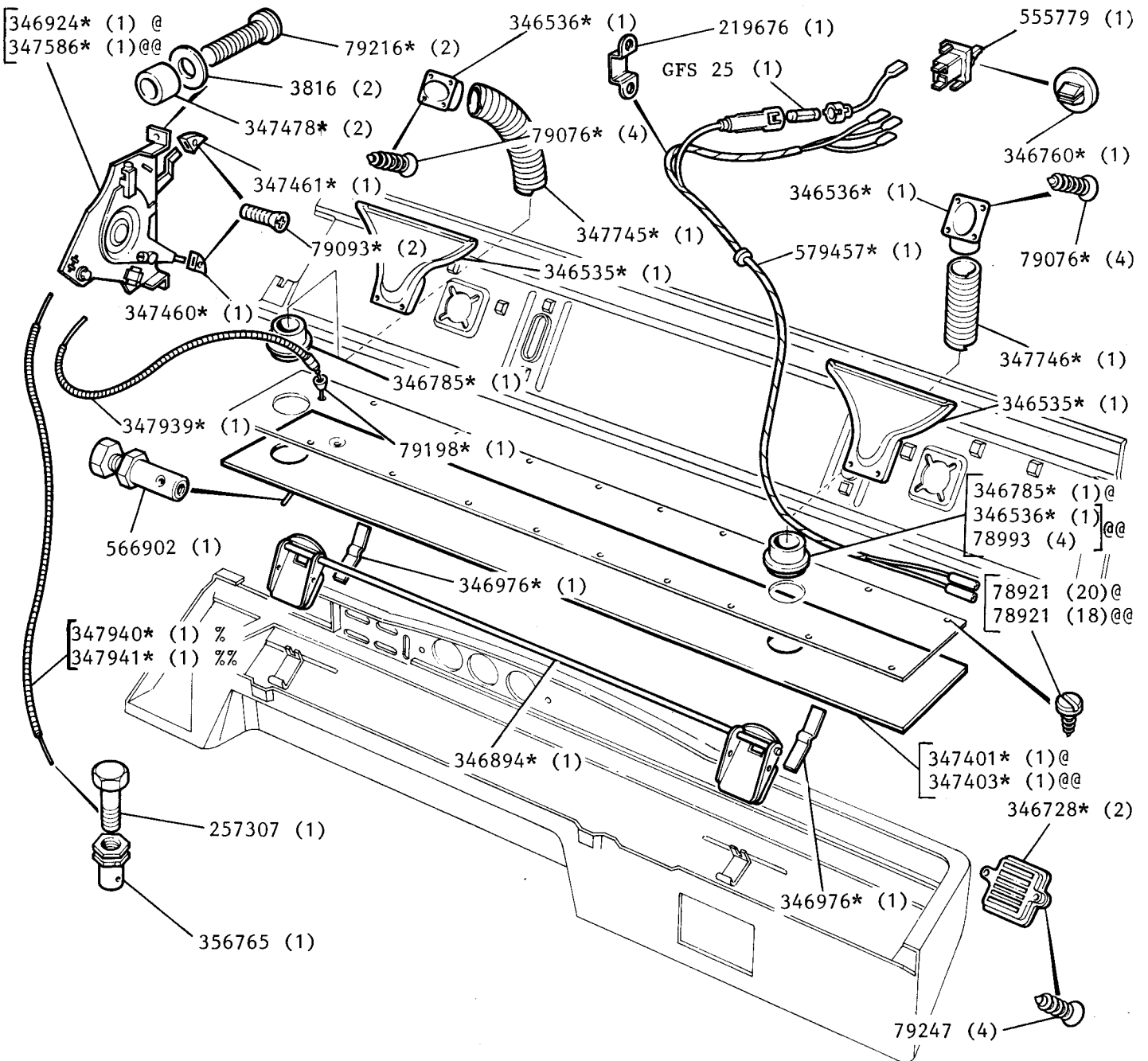

REMARKS

@ R.H.Stg

@@ L.H.Stg

% All except R.H.Stg 109" 2.6 models

%% R.H.Stg 109" 2.6 models

TWIN HORNS. SERIES IIA AND III EXCEPT FRANCE

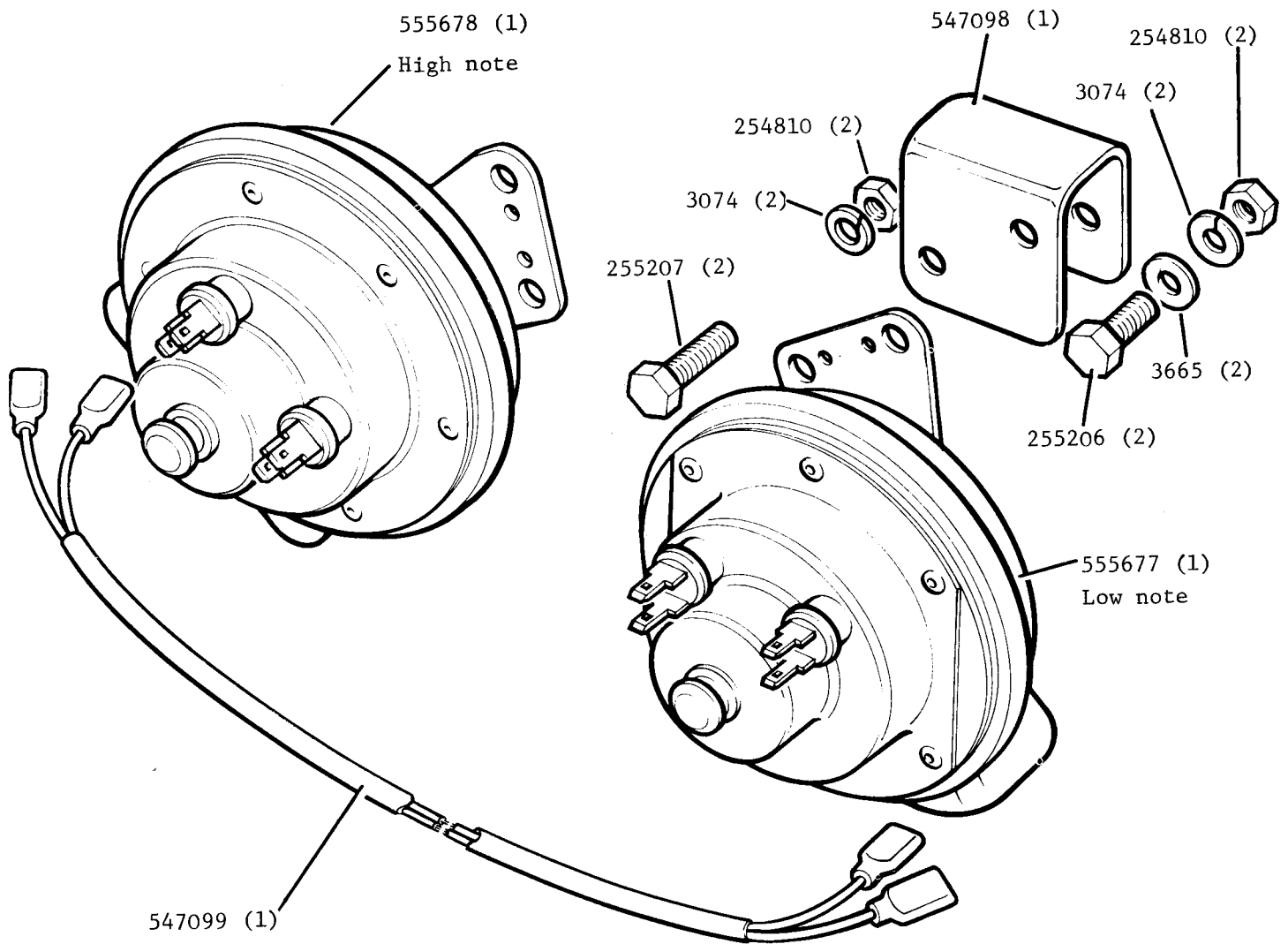

REMARKS

Twin Horn Kit 605134 (1)

TWIN HORNS SERIES III 2½ MODELS UP TO NOVEMBER 1971 FOR FRANCE ONLY

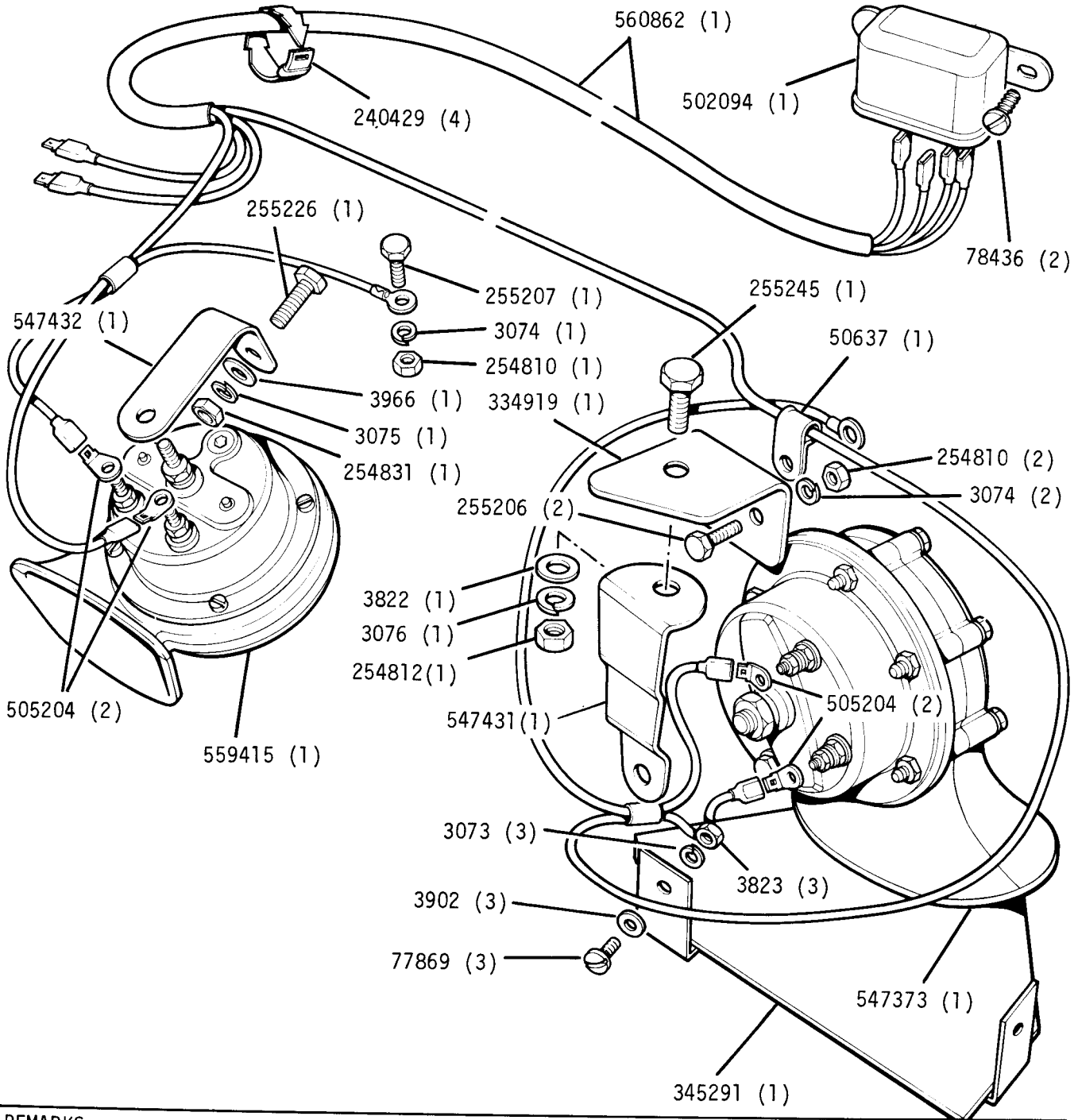

REMARKS

TWIN HORNS SERIES III 2½ MODELS FROM DECEMBER 1971 ONWARDS AND 2.6 MODELS FOR FRANCE ONLY

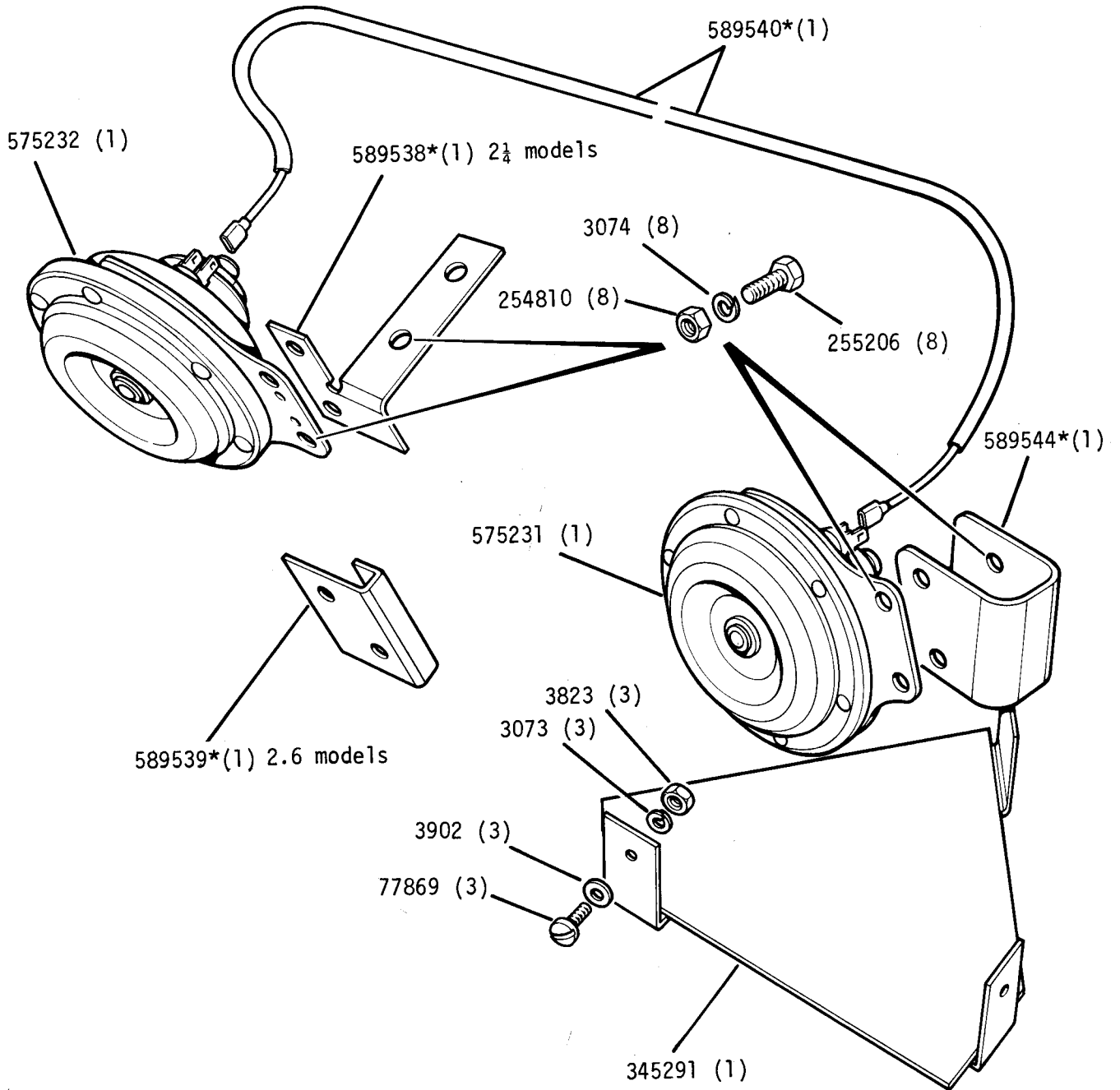

REMARKS

AMMETER SERIES III

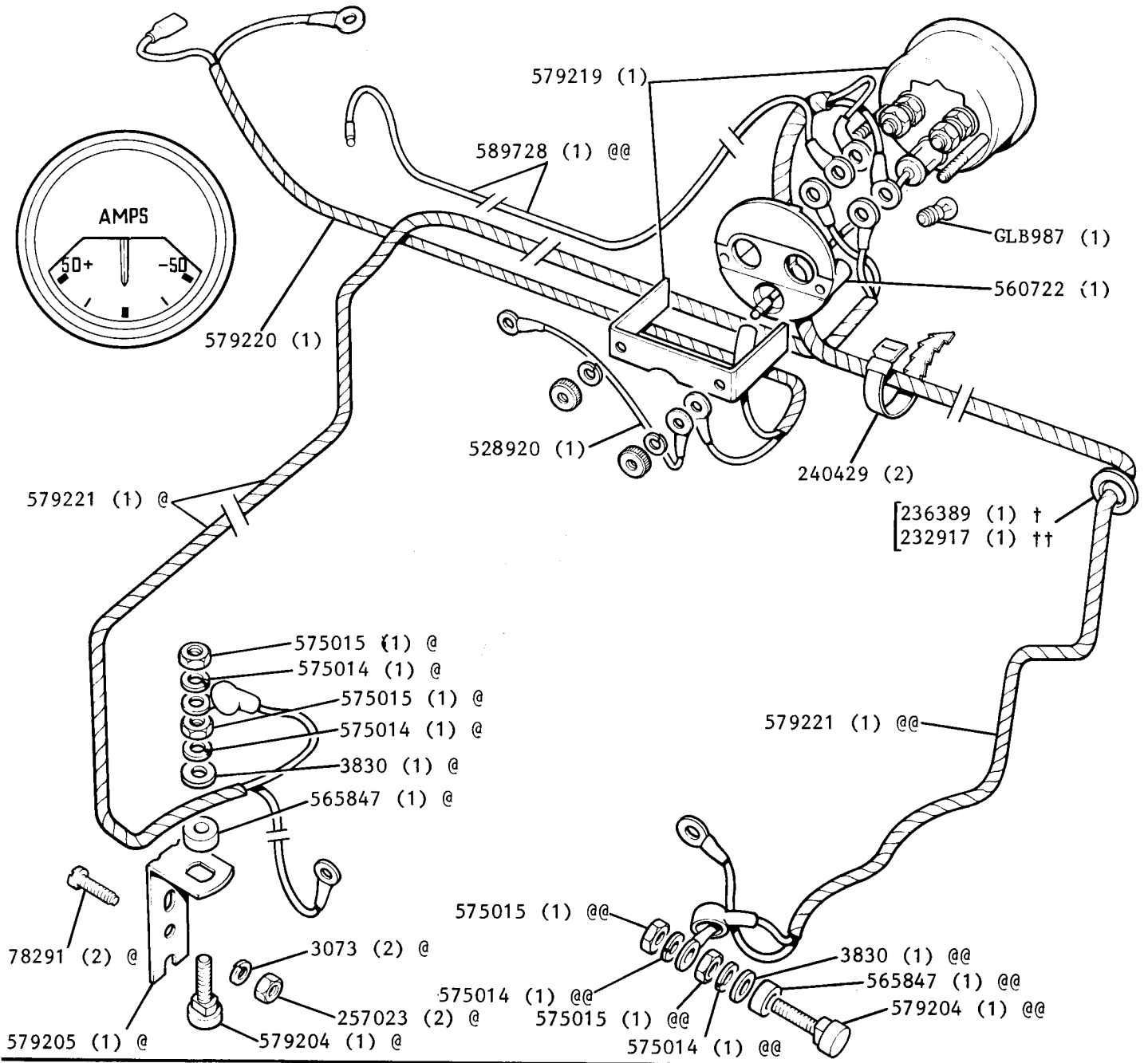

REMARKS

- Ammeter Kit 607696 (1) @
- Ammeter Kit 607734 (1) @@
- @ Petrol
- @@ Diesel
- † Ammeter extra only fitted
- †† Ammeter in conjunction with other electrical extras fitted

OIL PRESSURE GAUGE SERIES IIA AND III

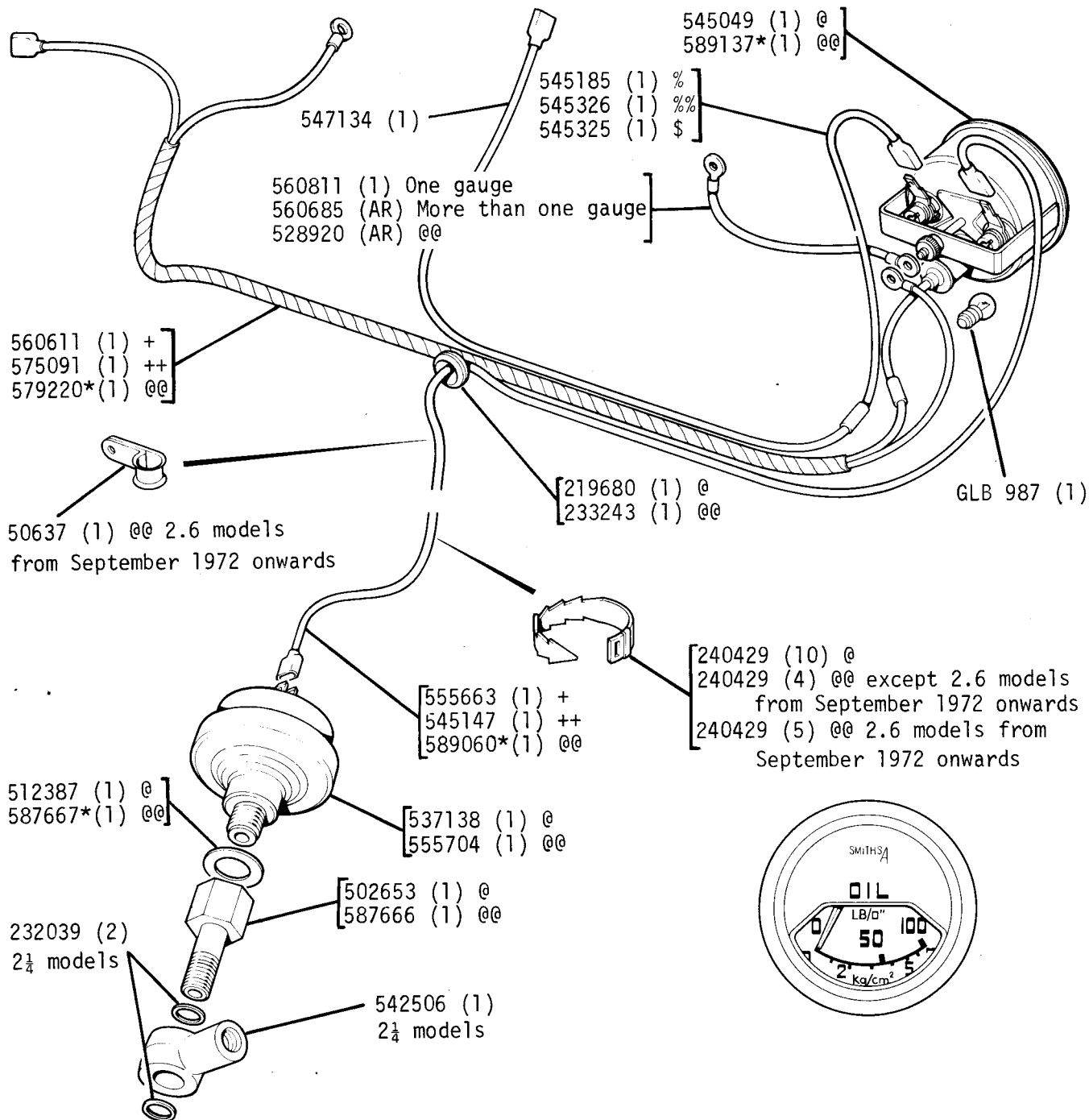

REMARKS

- Oil Pressure Gauge Kit 605252 (1) RH Stg ] @ @ Series IIA  
 Oil Pressure Gauge Kit 605253 (1) LH Stg ] @@ Series III  
 Oil Pressure Gauge Kit 607700\*(1) 2 1/4 ] @@  
 Oil Pressure Gauge Kit 607702\*(1) 2.6 ] @@  
 % Series IIA except N.A.D.A. vehicles Series III 2 1/4 models from September 1972 onwards  
 %% Series III 2 1/4 models up to August 1972 inclusive  
 \$ Series IIA N.A.D.A. vehicles only  
 + Series IIA up to August 1968 inclusive  
 ++ Series IIA from September 1968 onwards

REAR DOOR HINGES, PANEL AND FIXINGS, SERIES IIA AND III

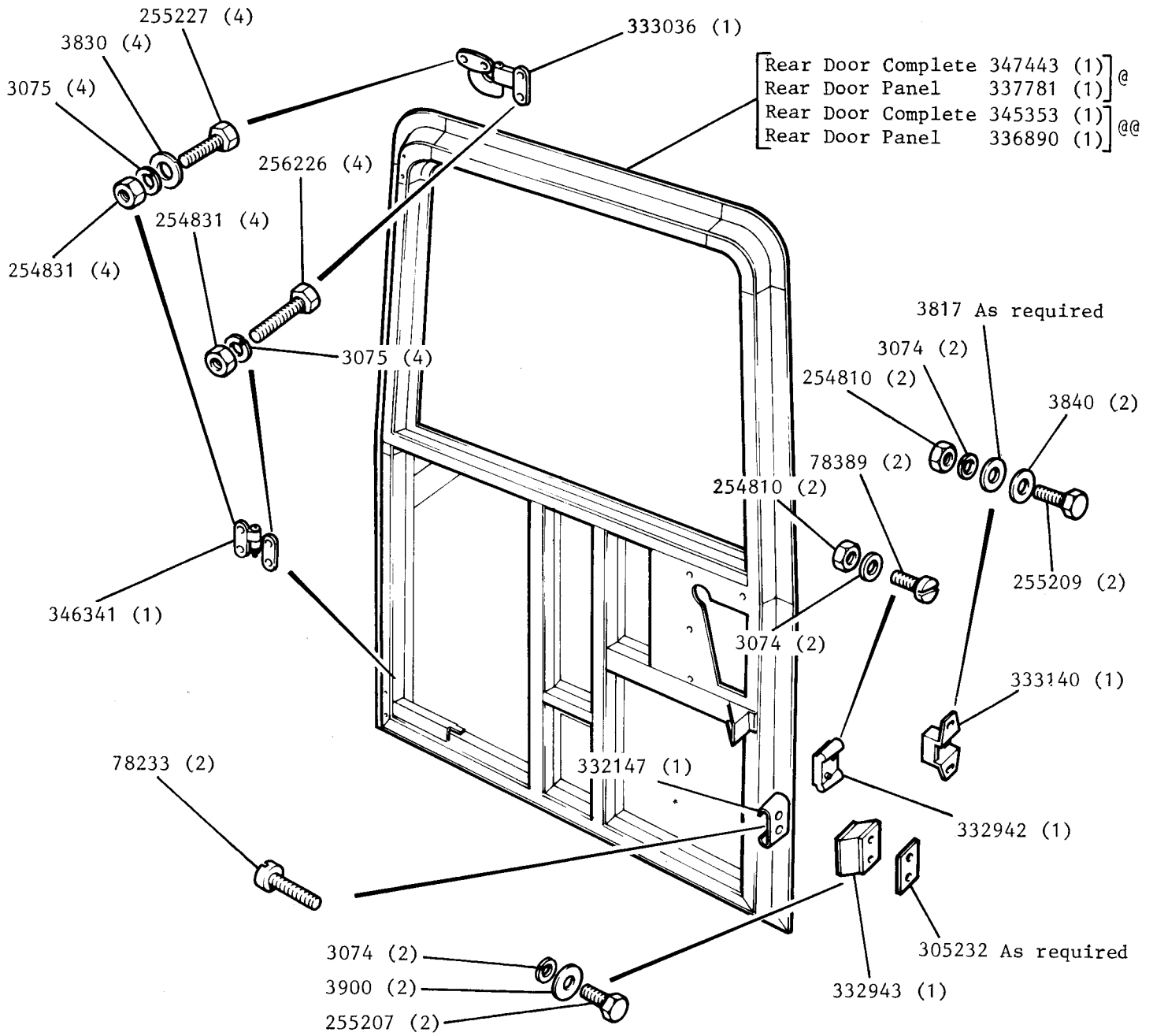

REMARKS

@ With Spare Wheel Support

@@ Less Spare Wheel Support

Rear Door, Plus Spare Wheel Carrier Kit 320777 (1)

Rear Door, Less Spare Wheel Carrier Kit 320828 (1)



REAR DOOR, LOCK, AND CARRIER. SERIES IIA AND III

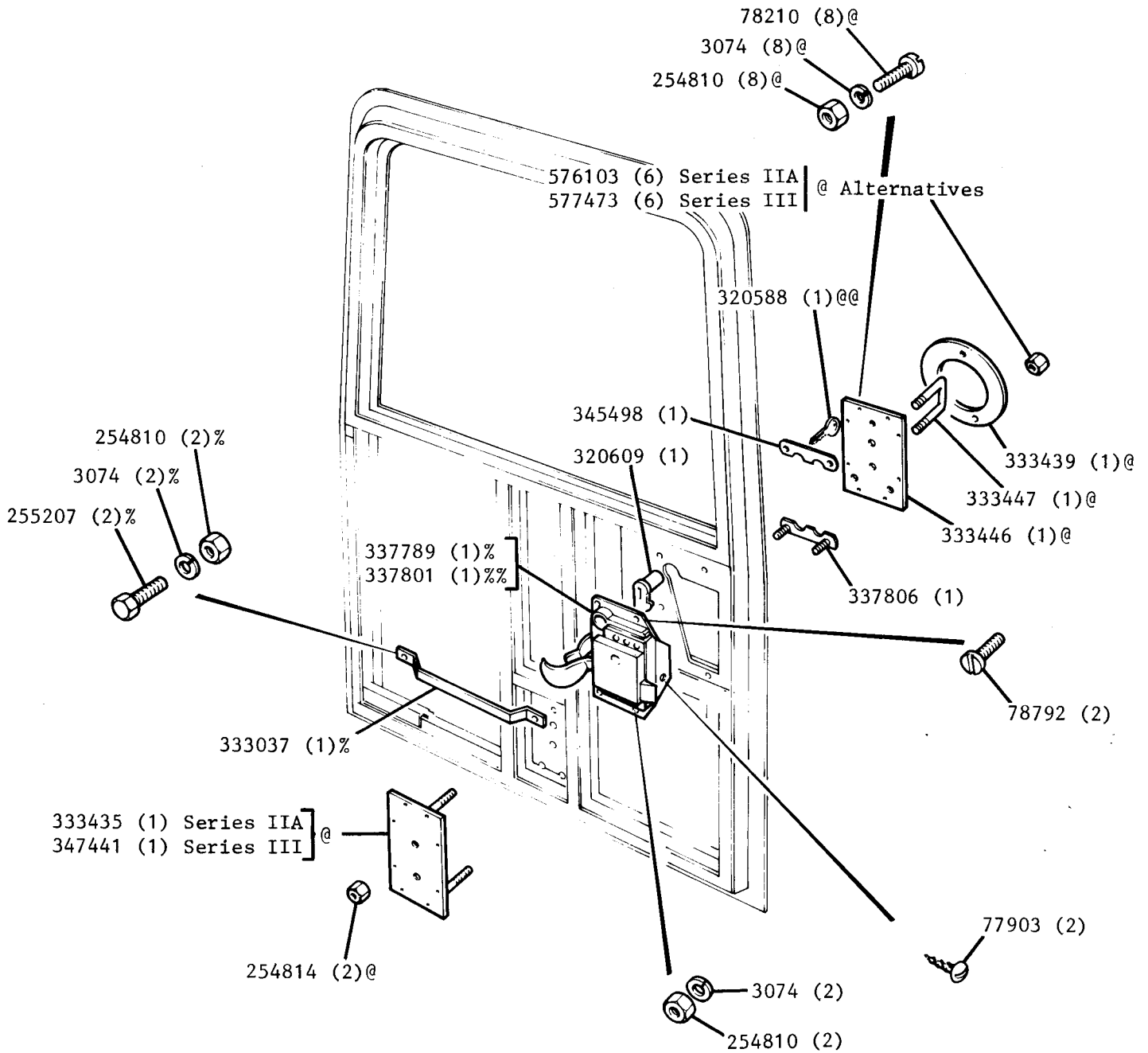

REMARKS

- @ For Rear End Door with Spare Wheel Carrier
- @@ State Key Number when Ordering
- % For Lock with Extended Inner Handle
- %% For Lock with Short Inner Handle

Rear Door, Plus Spare Wheel Carrier Kit 320777 (1)  
 Rear Door, Less Spare Wheel Carrier Kit 320828 (1)

REAR DOOR GLASS, SEALS AND CHECK STRAP SERIES IIA AND III

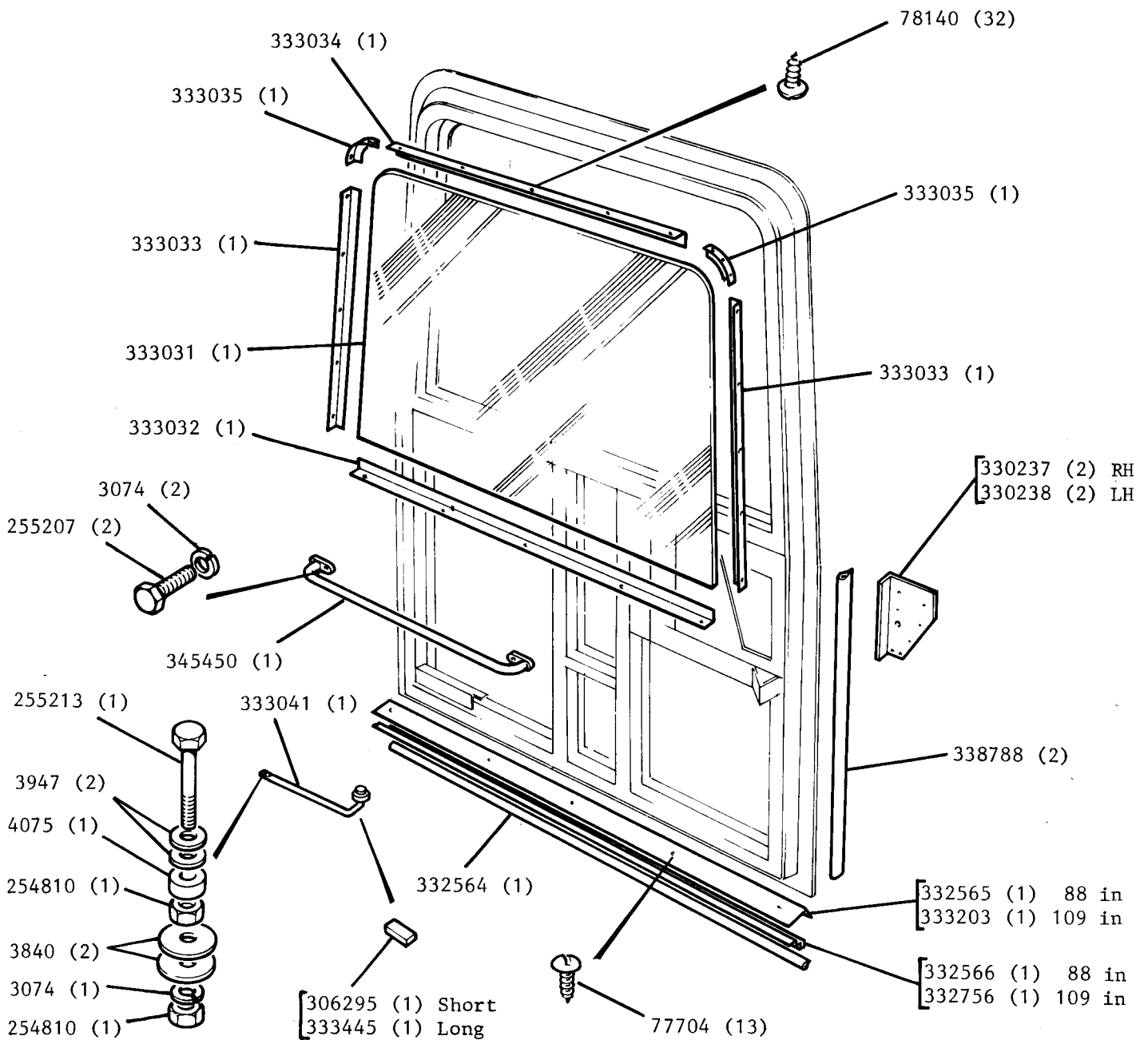

REMARKS

- Rear Door Plus Spare Wheel Carrier Kit 320777 (1)
- Rear Door Less Spare Wheel Carrier Kit 320828 (1)

REAR LID GLASS, SEALS, HINGE AND STAY, SERIES IIA AND III

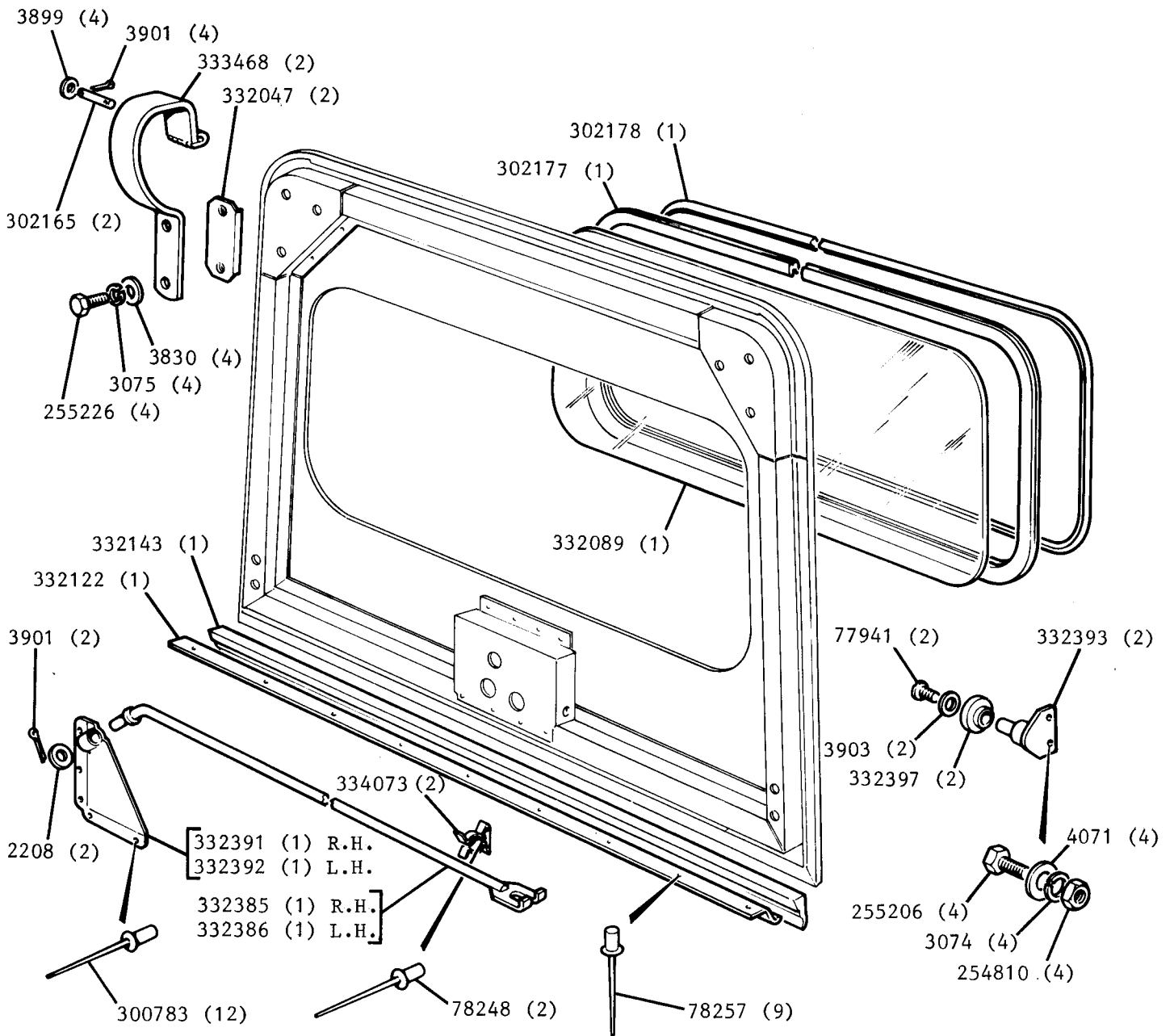

REMARKS

Rear Lid Complete Assembly 320652 (1)

REAR LID LOCK AND SOCKET, SERIES IIA AND III

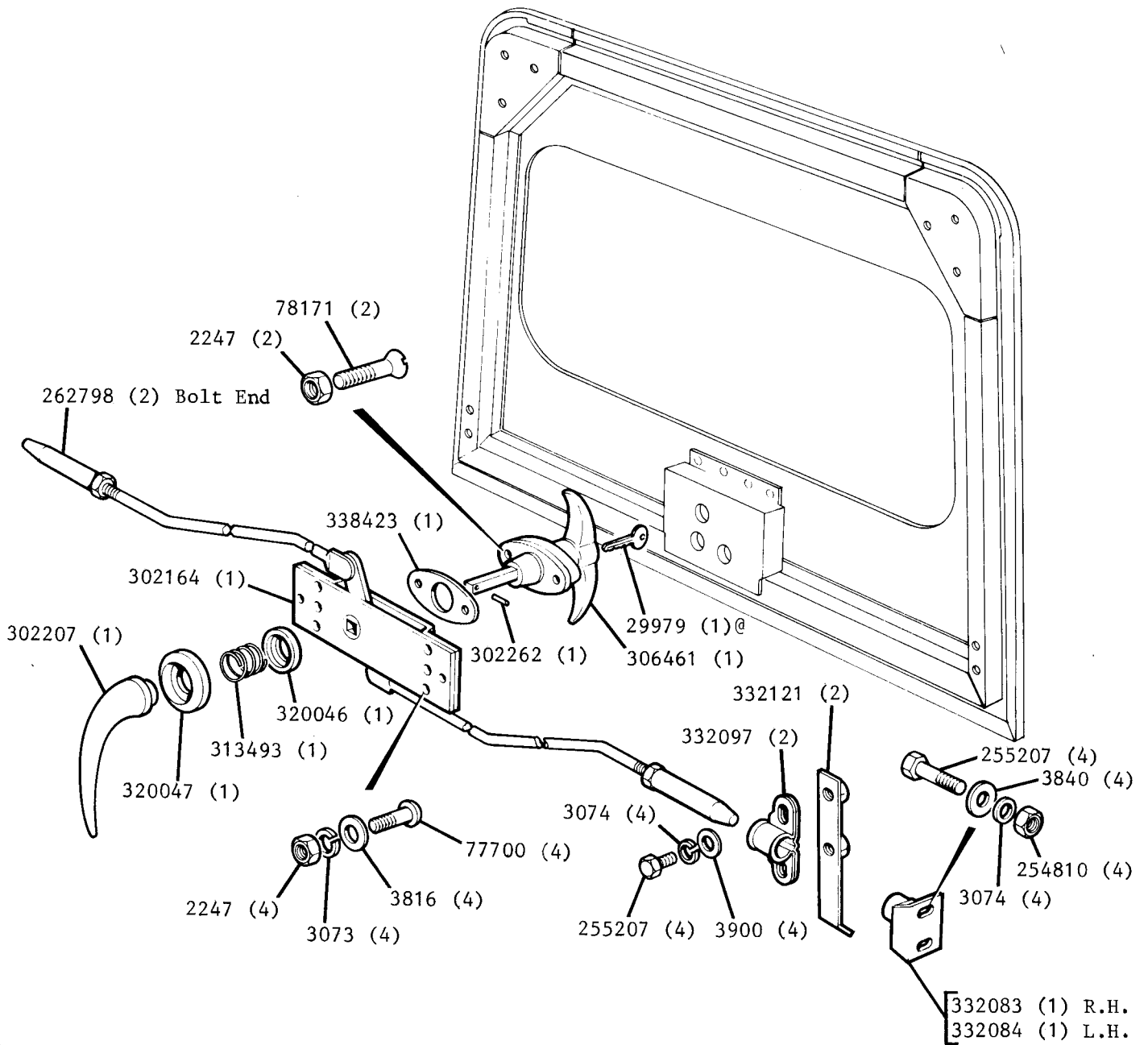

REMARKS

Rear Lid Complete Assembly 320652 (1)  
 @ State Key Number When Ordering

HARD TOP ROOF PANELS AND FIXINGS. SERIES IIA AND III 88"

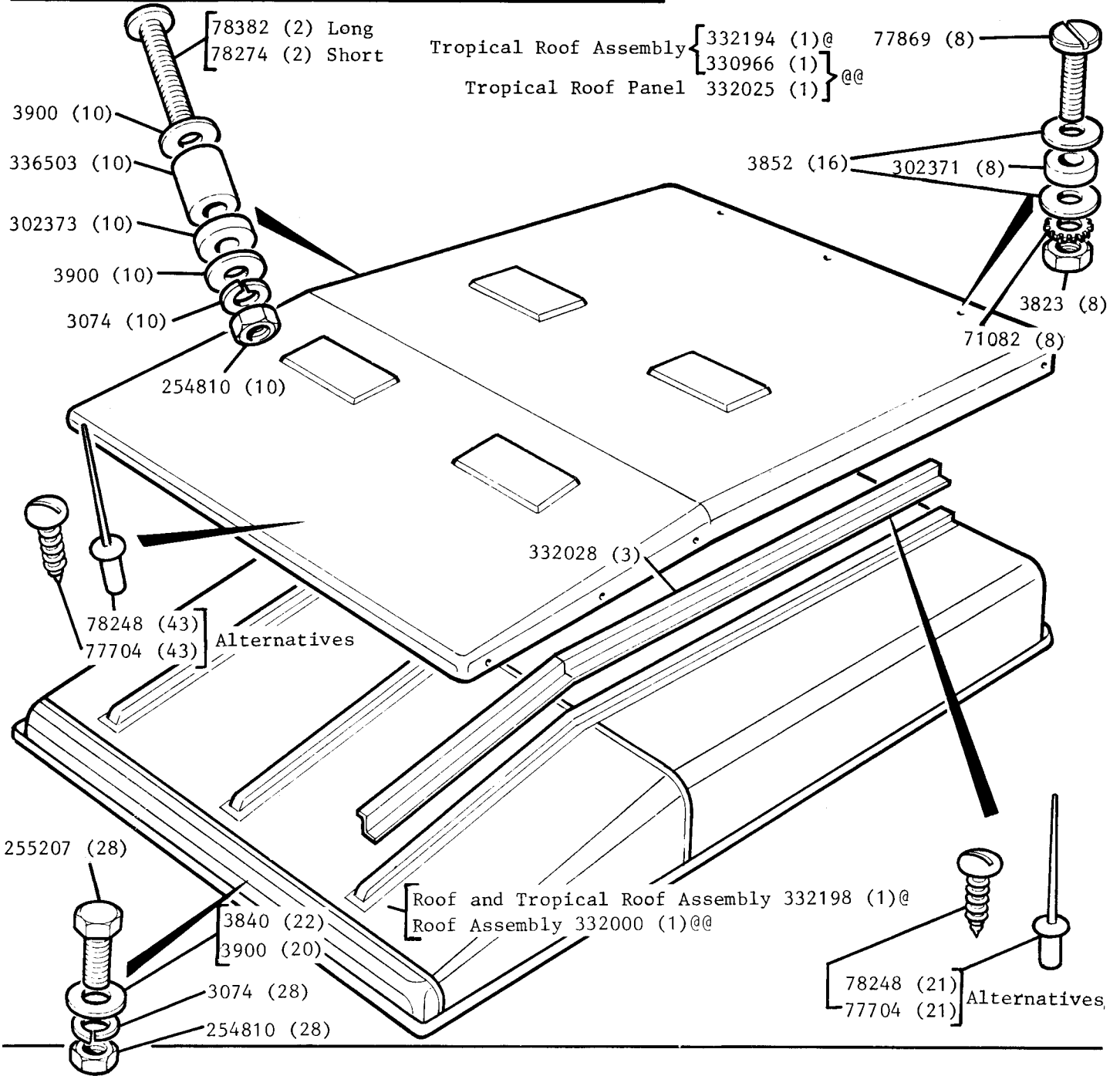

REMARKS

- @ Station Wagon type Roof
- @@ Hard Top type Roof

HARD TOP ROOF SEALS, VENTILATORS AND ALPINE LIGHT SERIES IIA AND III 88"

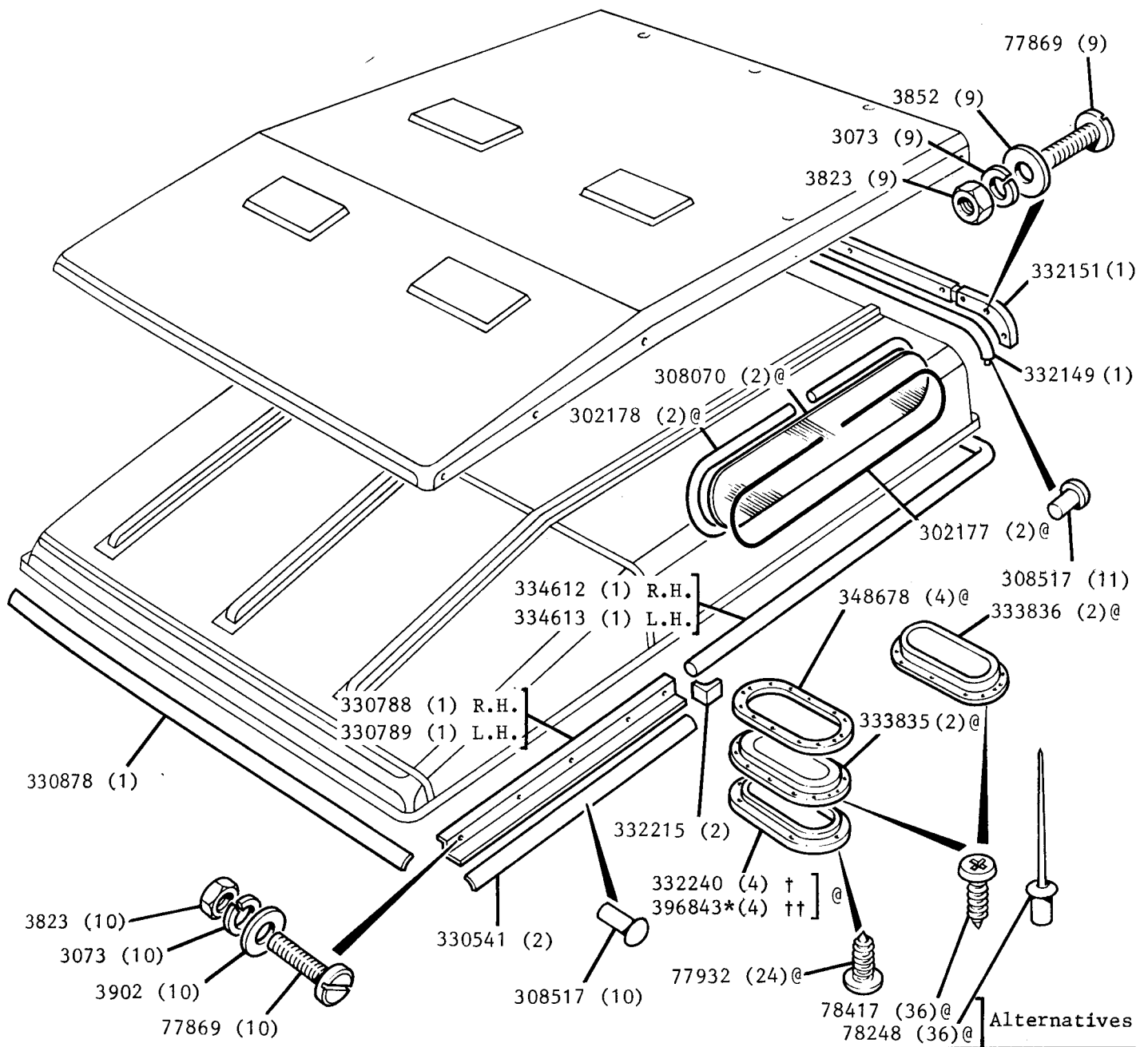

REMARKS

- @ Station Wagon Type Roof
- † White
- †† Limestone

HARD TOP ROOF PANELS AND FIXINGS, SERIES IIA AND III 109"

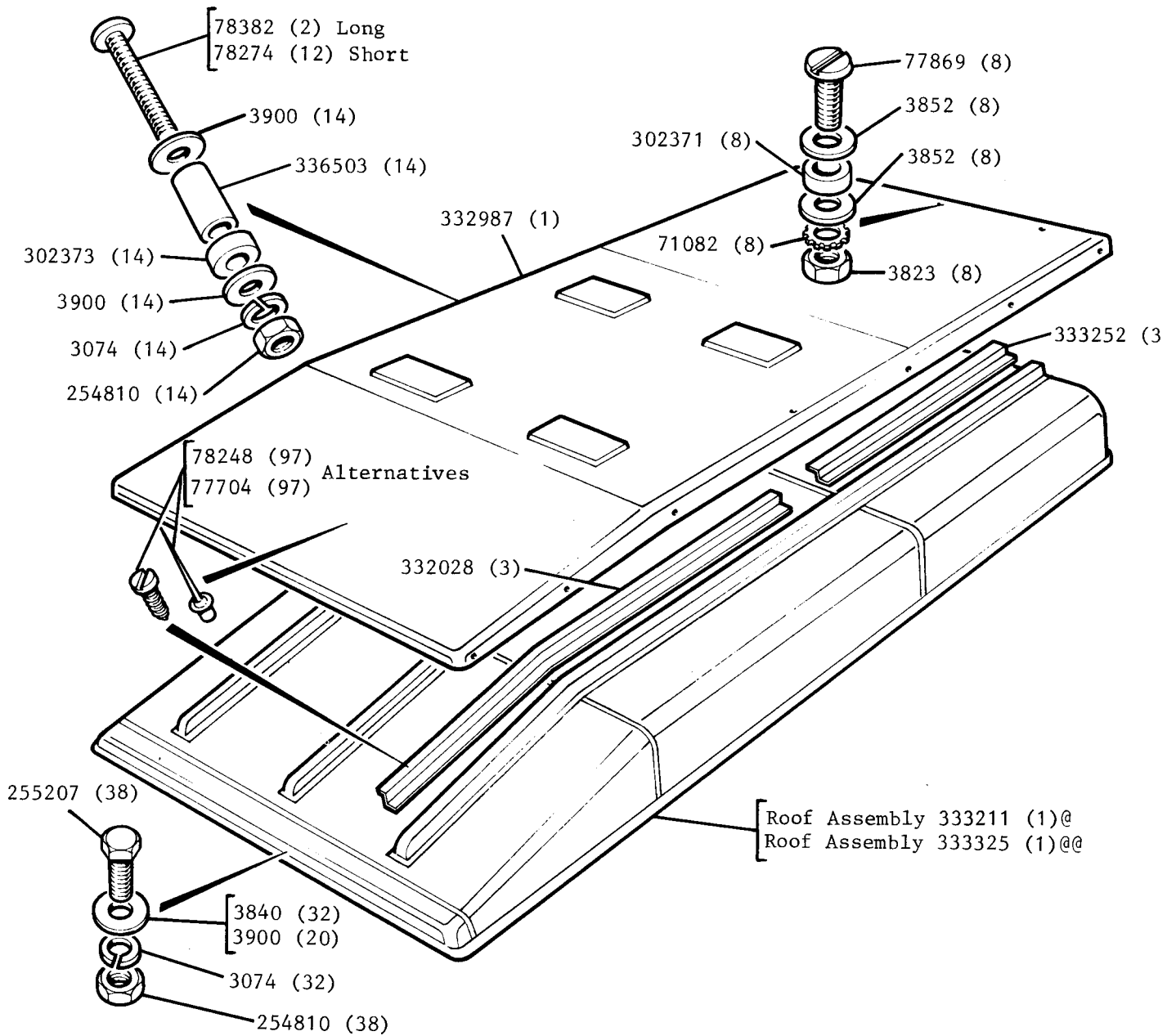

REMARKS

@ Station Wagon type Roof  
@@ Hard Top type Roof

HARD TOP ROOF SEALS, VENTILATORS AND ALPINE LIGHT SERIES IIA AND III 109"

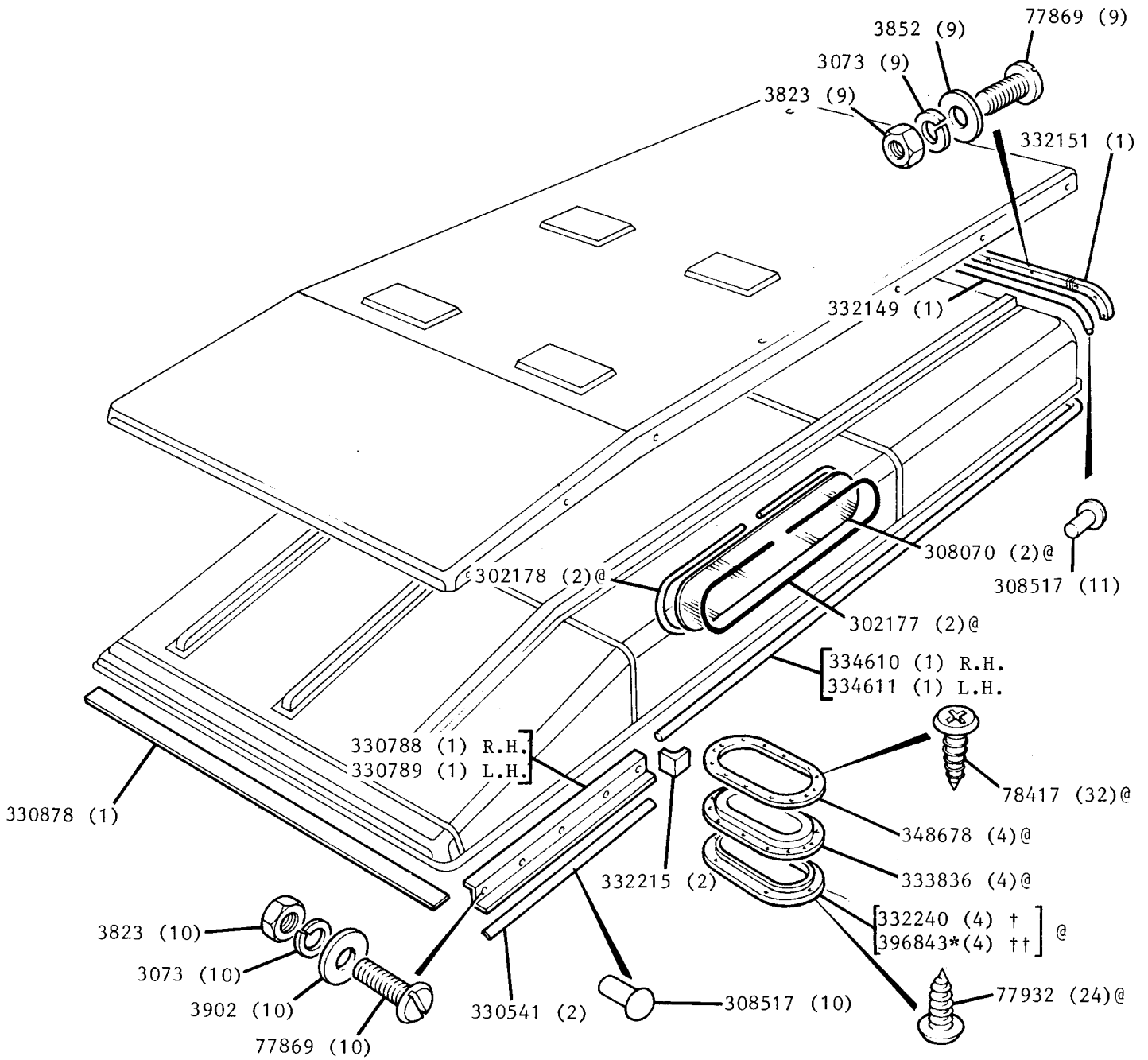

REMARKS

- @ Station Wagon Type Roof
- † White
- †† Limestone



FULL LENGTH HOOD. SERIES 11A AND 111 88in

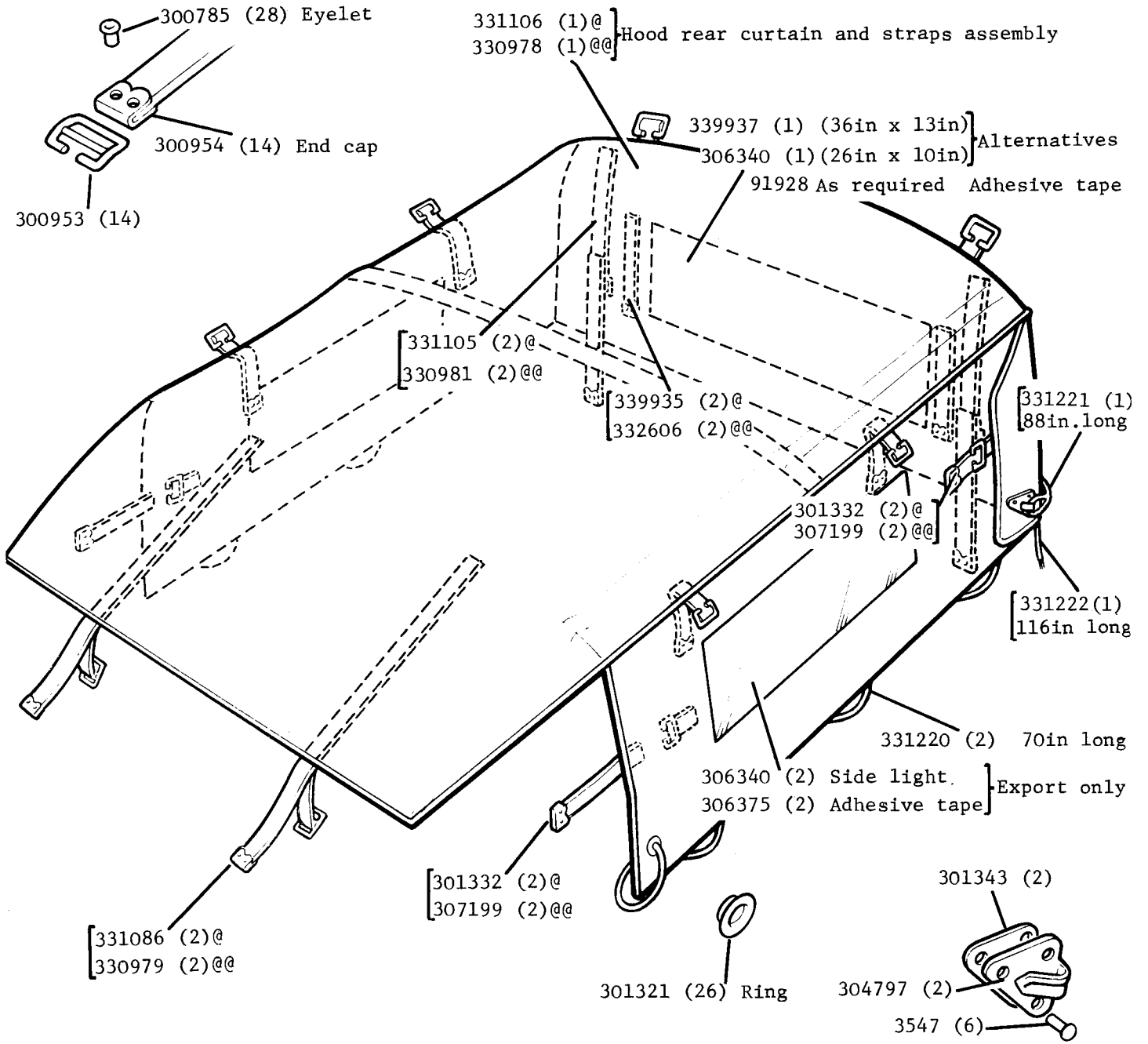

REMARKS

- Hood Complete, Full Length, Plain Sides, Green 331110 (1)
  - Hood Complete, Full Length, Plain sides, Blue 330982 (1)
  - Hood Complete, Full Length, With Side Windows, Green 331113 (1)
  - Hood Complete, Full Length, With Side Windows, Blue 330983 (1) } Export only
- @Green @@ Blue

FULL LENGTH HOOD. SERIES 11A AND 111 109in.

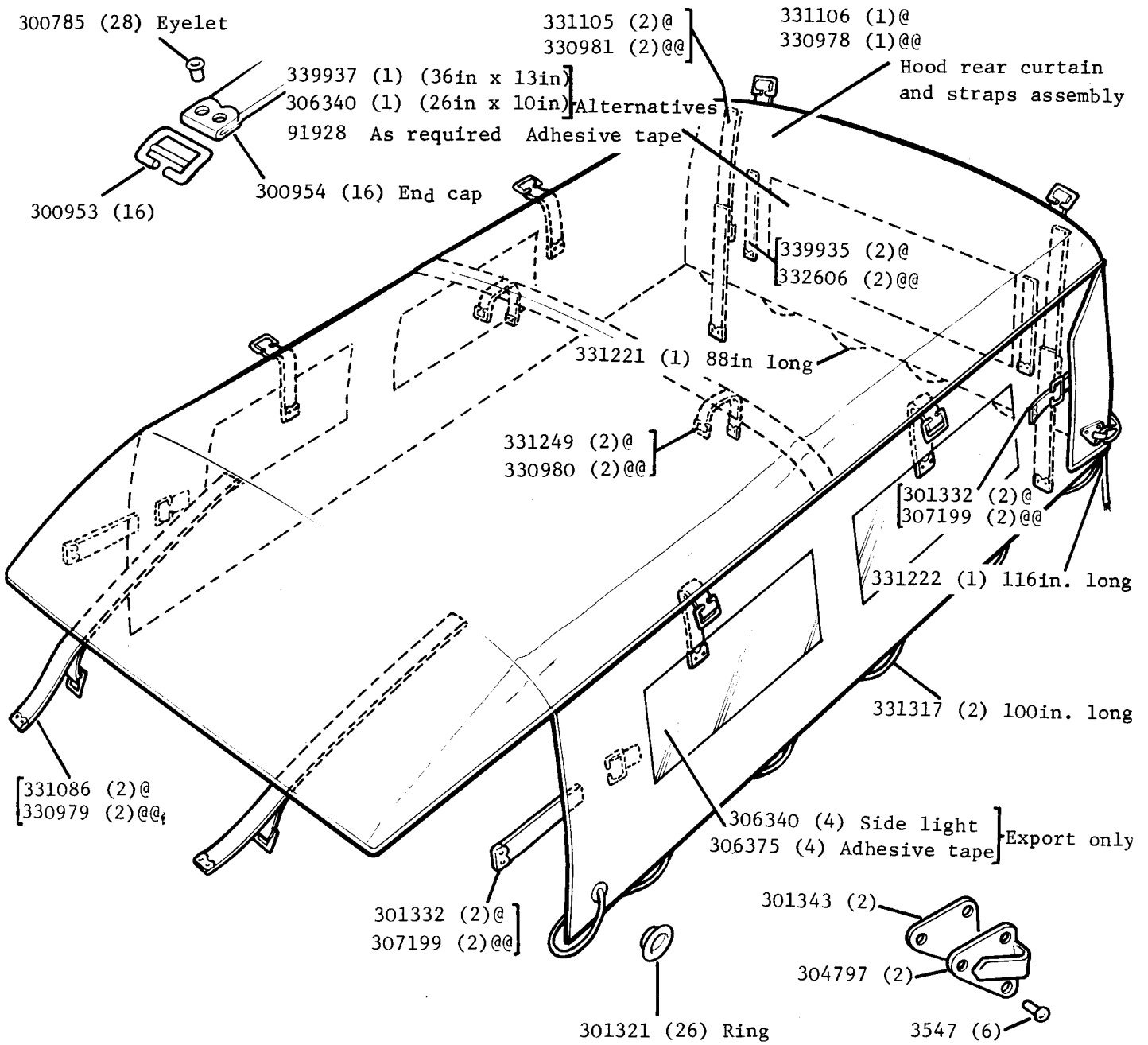

REMARKS

- Hood Complete Full Length, Plain Sides, Green 331259 (1)
  - Hood Complete Full Length Plain Sides, Blue 330984 (1)
  - Hood Complete, Full Length, With Side windows, Green 331260 (1)
  - Hood Complete, Full Length, With Side windows Blue 330985 (1)
- } Export only
- @ Green    @@ Blue

FULL LENGTH HOOD, FRONT FIXINGS. SERIES 11A AND 111 88in AND 109in

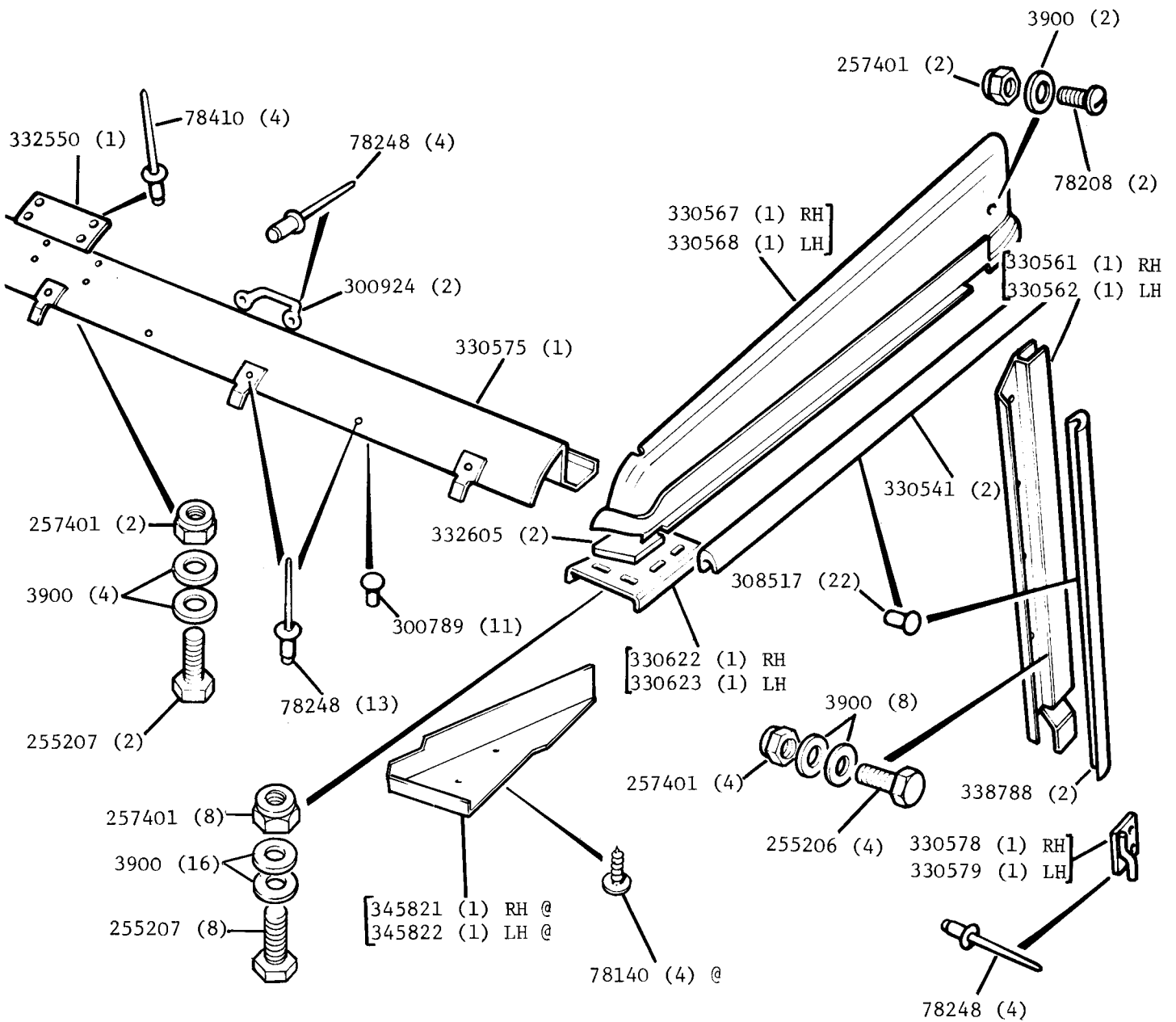

REMARKS

Hoodsticks And Fixings Complete 330999 (1) 88in.  
 Hoodsticks And Fixings Complete 332951 (1) 109in.  
 @ Not part of Hoodsticks and Fixings Kit

FULL LENGTH HOODSTICKS. SERIES 11A AND 111 88in.

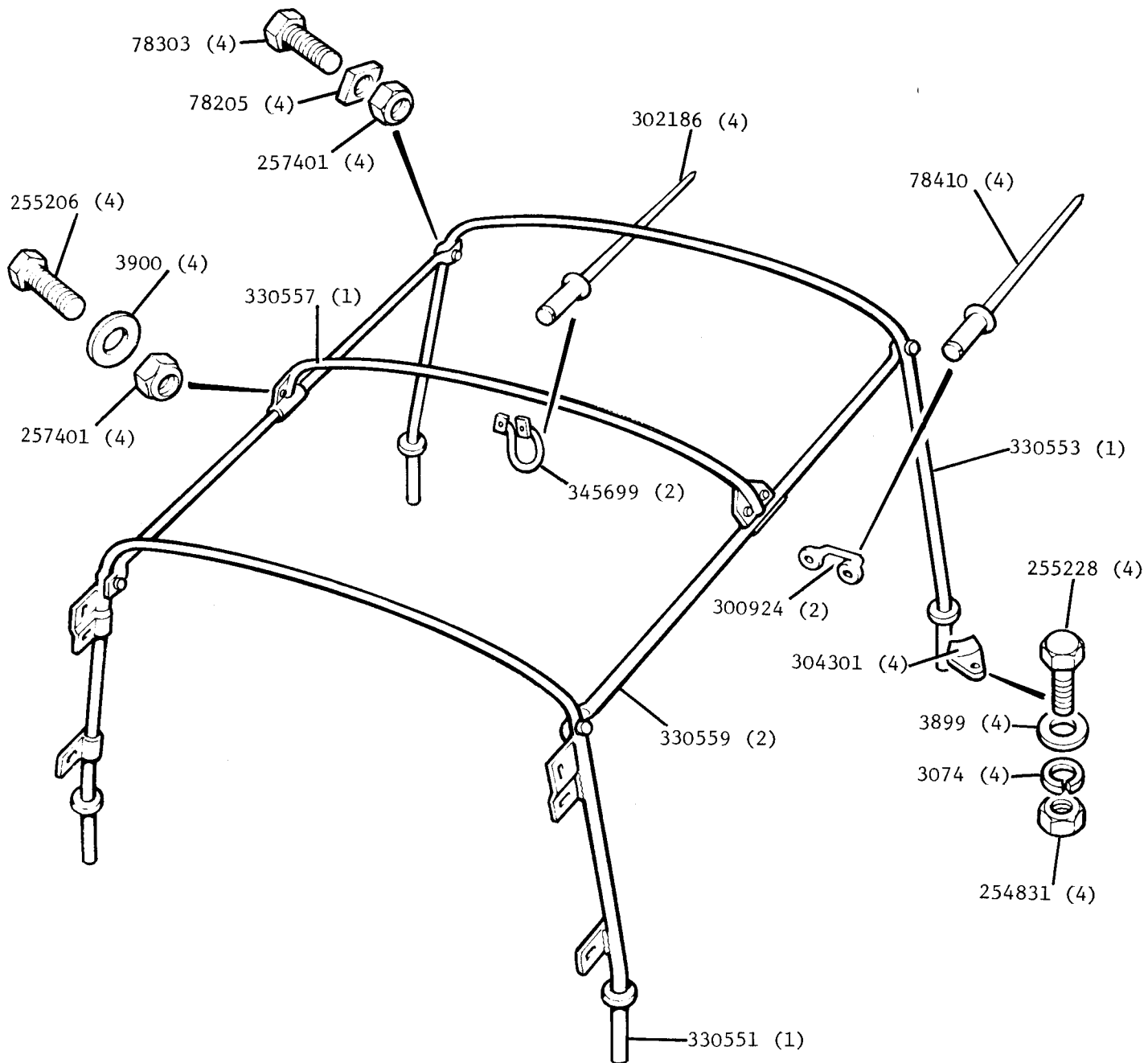

REMARKS

Hoodsticks And Fixings Complete 330999 (1)

THREE-QUARTER LENGTH HOOD SERIES 11A AND 111 88in.

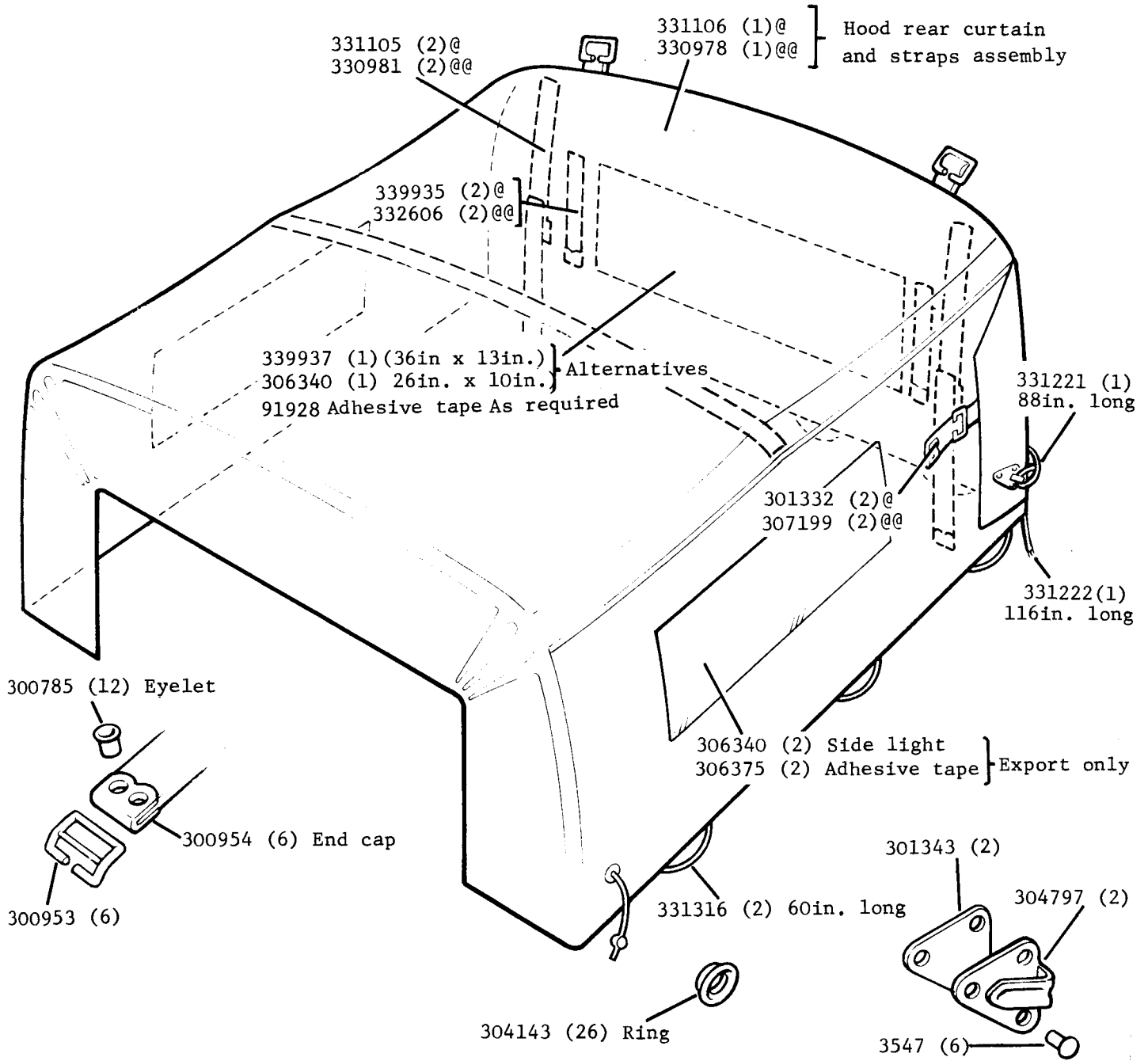

REMARKS

- Hood complete, Three-Quarter Length Plain Sides, Green 331371(1)
  - Hood complete, Three-Quarter Length Plain Sides, Blue 330986 (1)
  - Hood complete, Three-Quarter Length With Side Windows, Green 331372(1)
  - Hood complete, Three Quarter Length With Side Windows, Blue 330987(1) } Export only
- @ Green  
@@Blue

THREE-QUARTER LENGTH HOOD SERIES 11A AND 111 109 in.

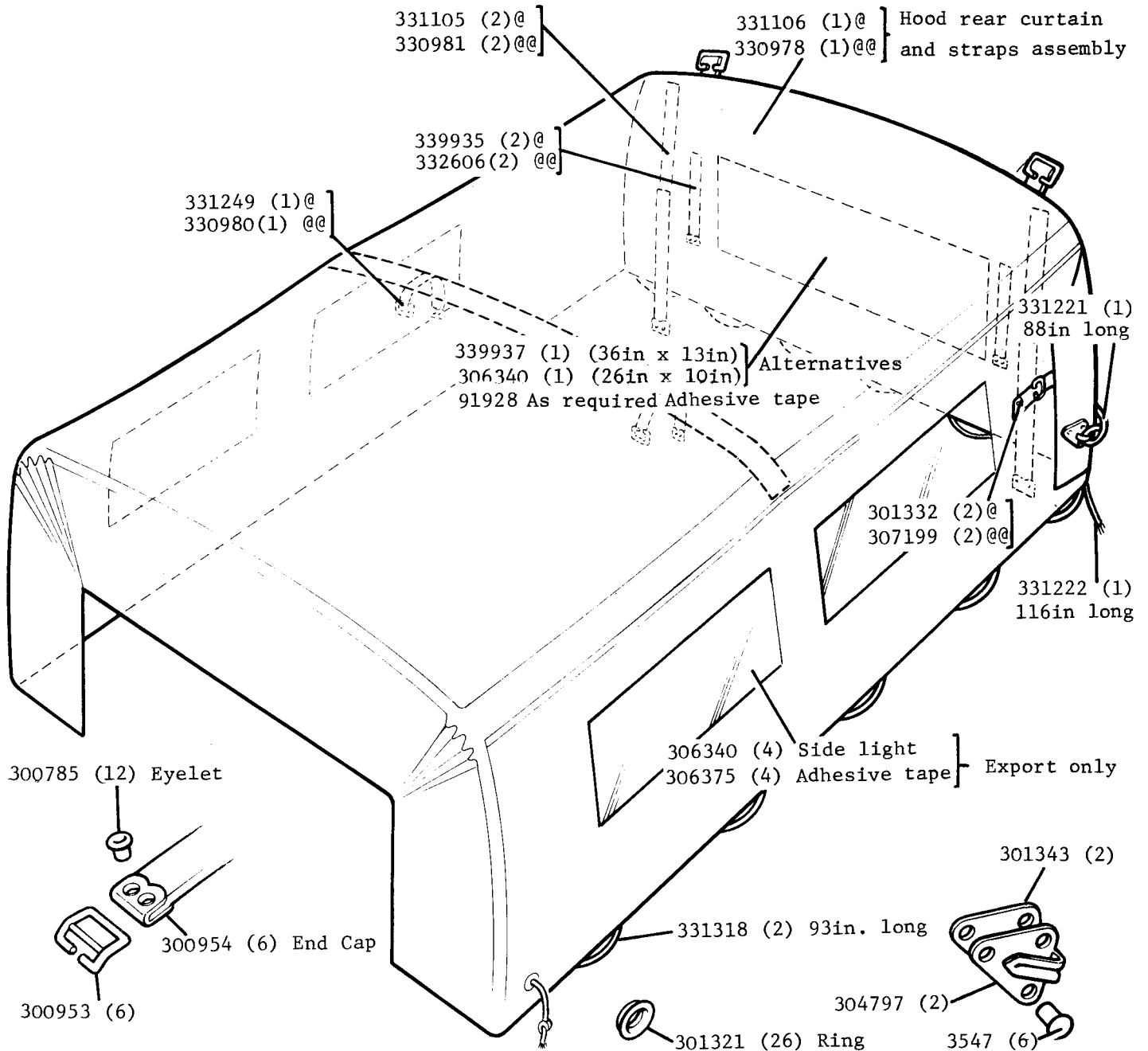

REMARKS

- Hood Complete, Three-Quarter Length Plain Sides, Green 331307 (1)
- Hood Complete, Three-Quarter Length, Plain Sides, Blue 330997 (1)
- Hood Complete, Three-Quarter Length With Side Windows, Green 331308 (1) } Export only
- Hood Complete, Three-Quarter Length With Side Windows, Blue 330998 (1) }
- @ Green
- @@ Blue

THREE-QUARTER LENGTH HOODSTICKS SERIES 11A AND 111 88in.

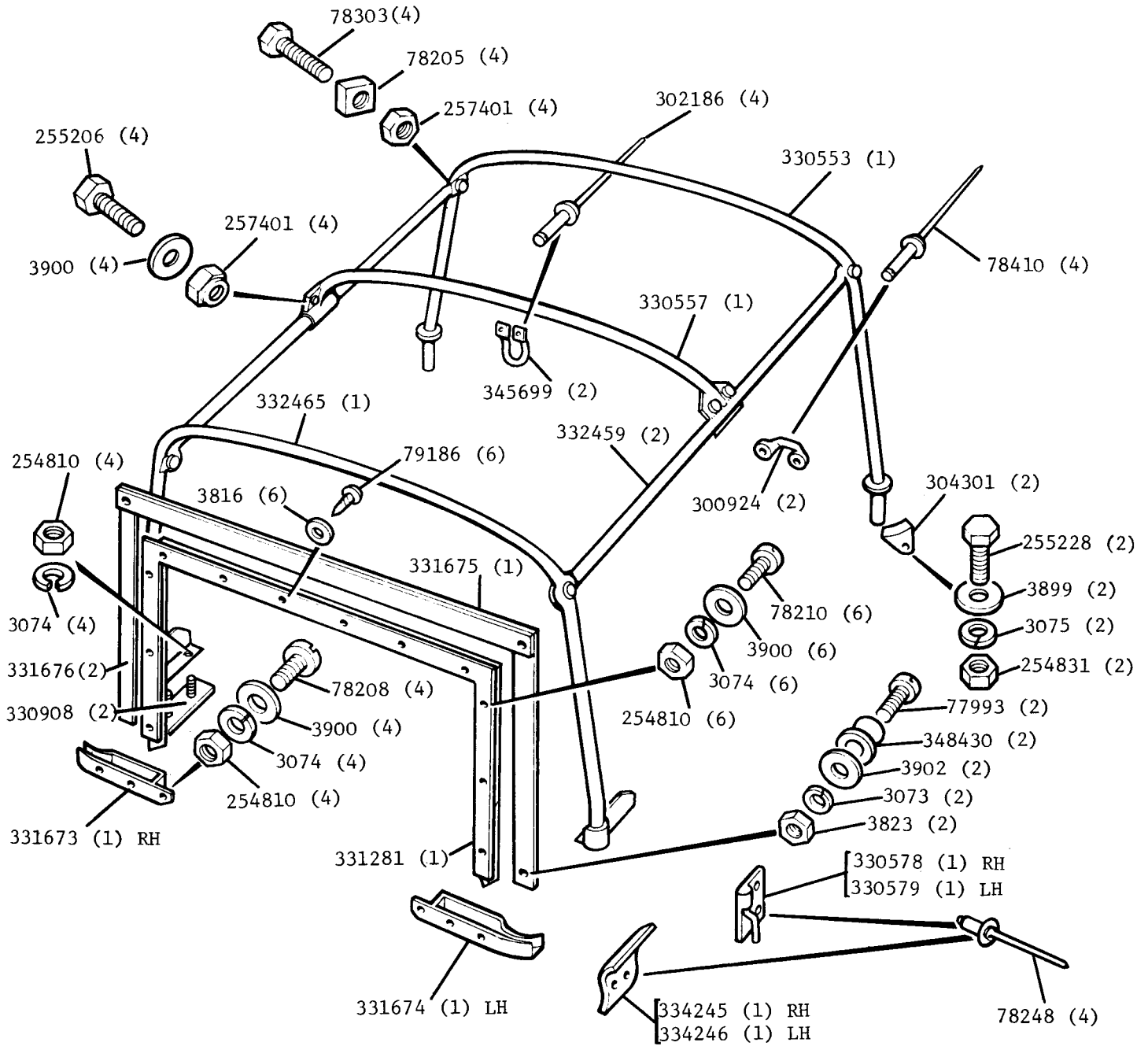

REMARKS

Hoodsticks And Fixings Complete 332950 (1)

THREE-QUARTER LENGTH HOODSTICKS SERIES 11A AND 111 109 in.

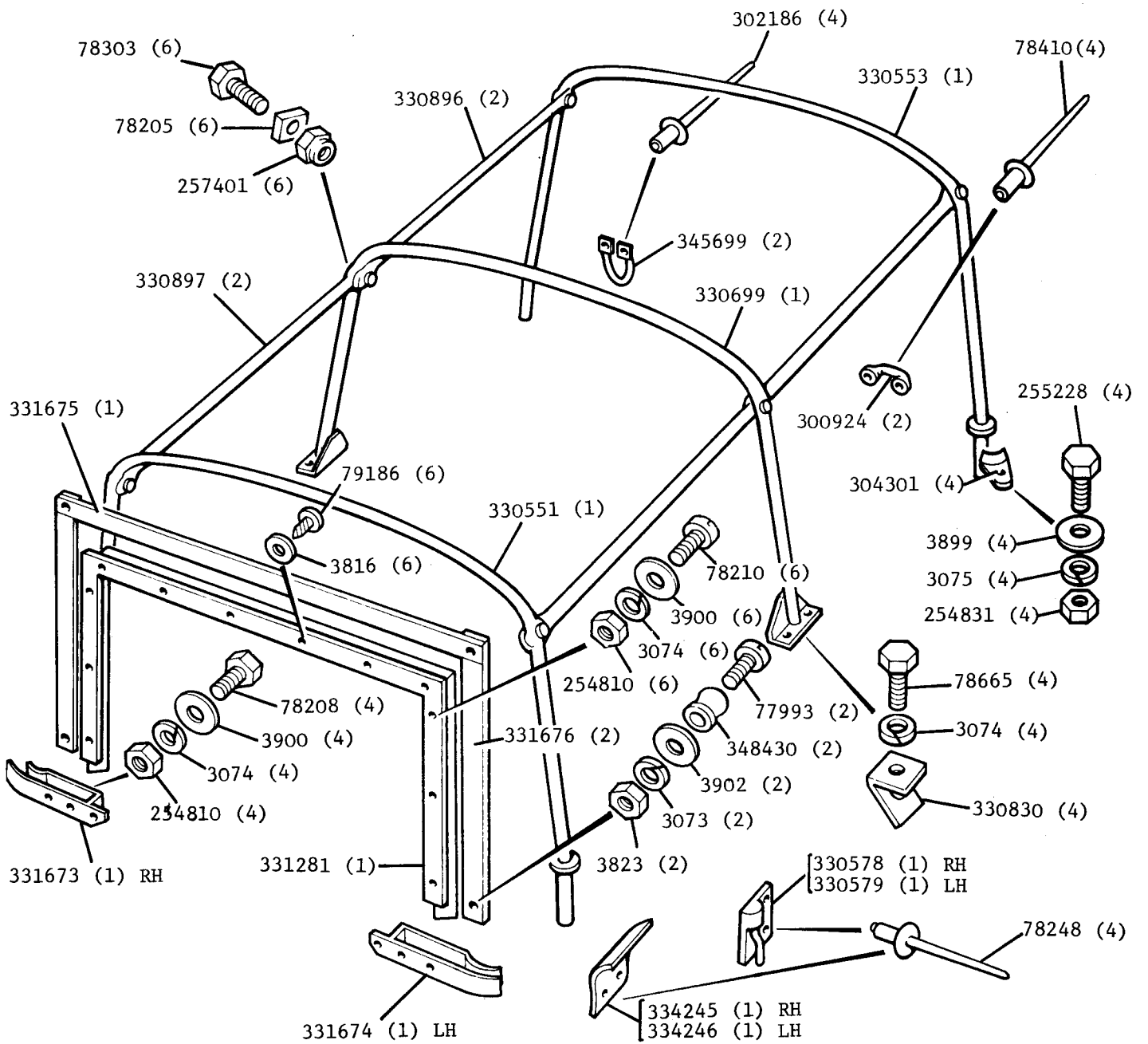

REMARKS

Hoodsticks and Fixings Complete 332952 (1)



HARD TOP BODYSIDE, SEALS AND REAR GLASS, SERIES IIA AND III

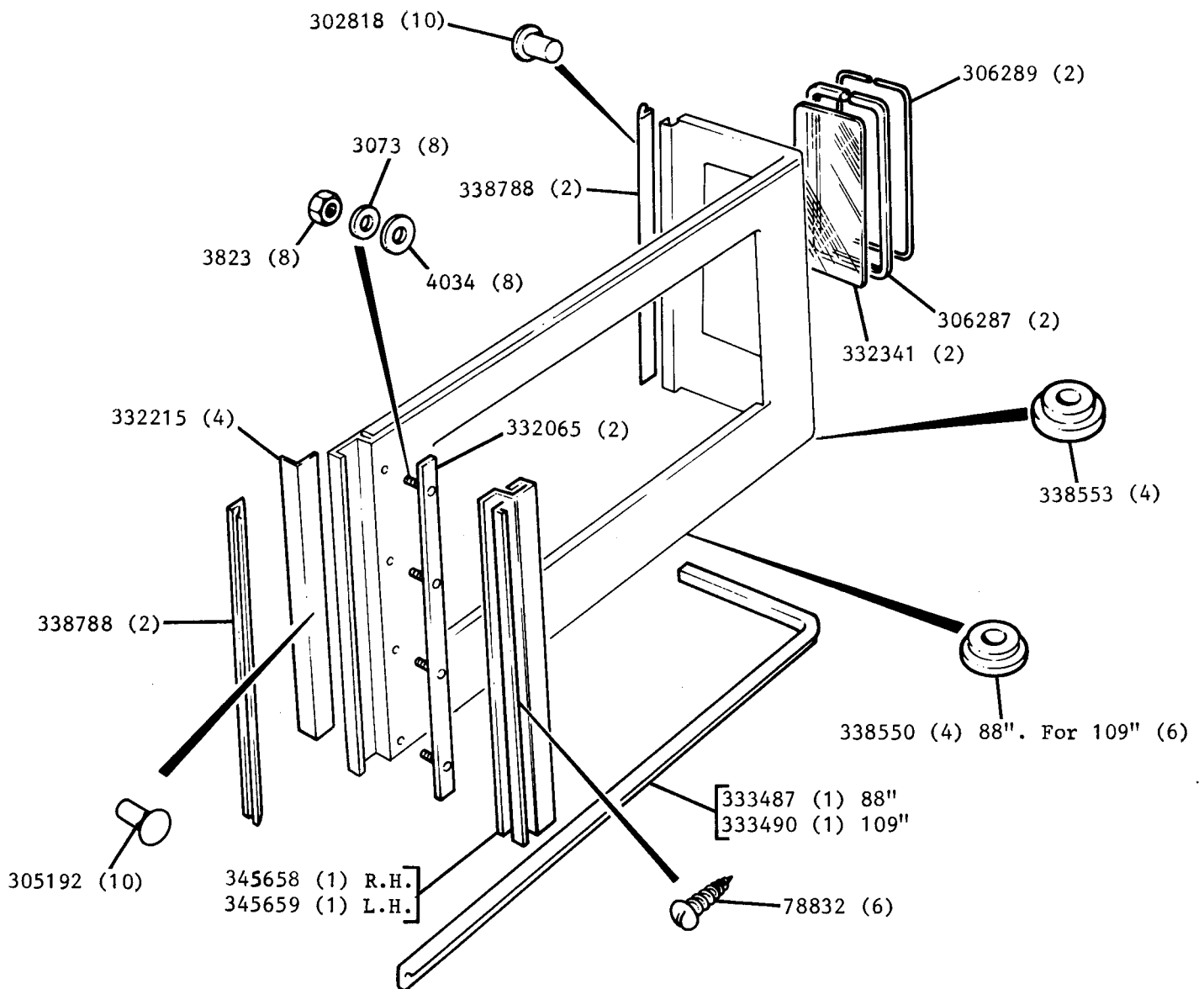

REMARKS

Bodyside Assembly R.H.	334719	(1)	109 in	Plain sides	Export only
Bodyside Assembly L.H.	334720	(1)			
Bodyside Assembly R.H.	334707	(1)	88 in	Fixed	
Bodyside Assembly L.H.	334708	(1)			
Bodyside Assembly R.H.	334725	(1)	109 in	Windows	
Bodyside Assembly L.H.	334726	(1)			
Bodyside Assembly R.H.	334713	(1)	88 in	Sliding Windows	
Bodyside Assembly L.H.	334714	(1)			
Bodyside Assembly R.H.	332306	(1)	88 in With		
Bodyside Assembly L.H.	332307	(1)	Sliding Windows		

HARD TOP BODYSIDE FIXINGS SERIES IIA AND III

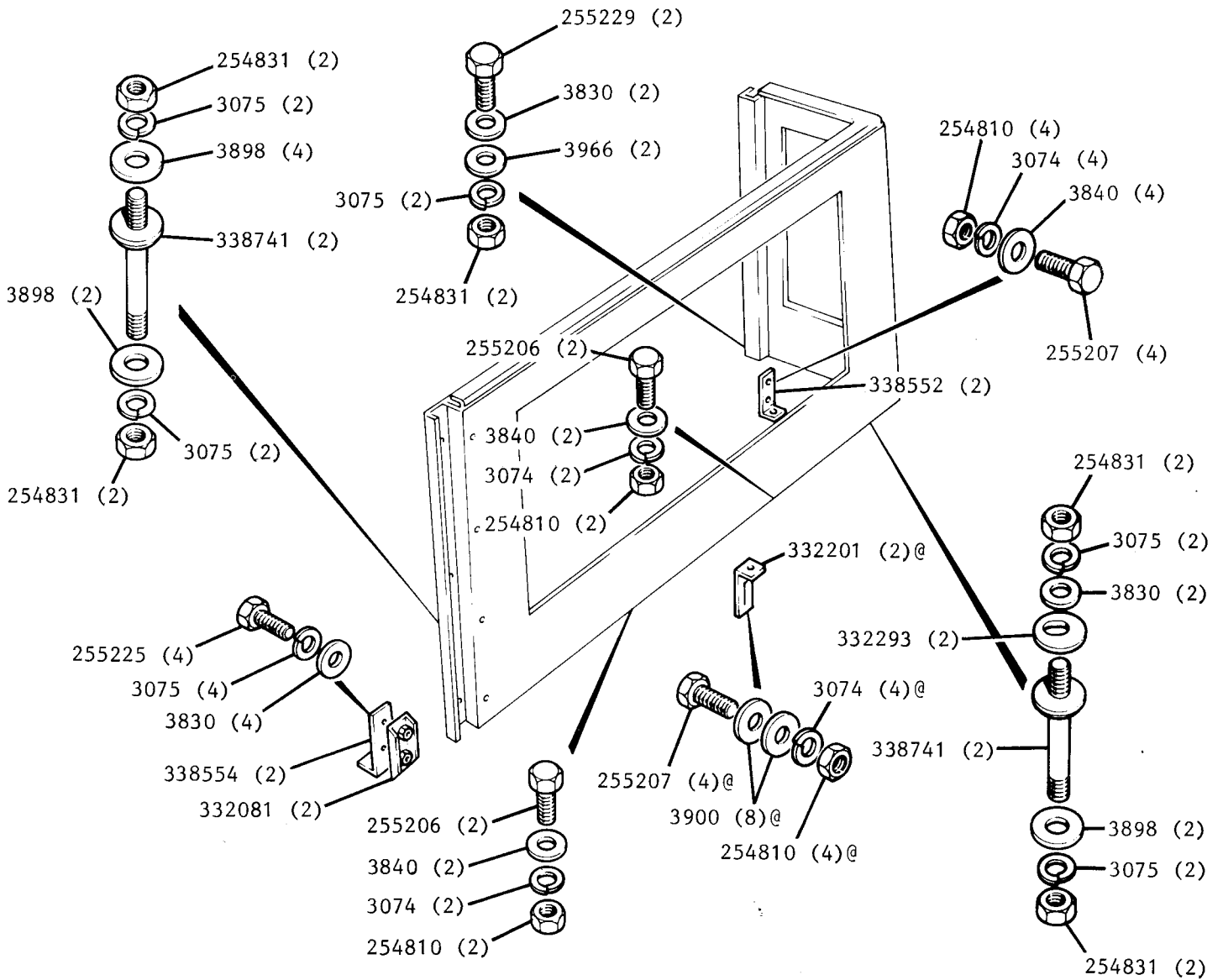

REMARKS

@ Double quantity for 109" models

HARD TOP BODYSIDE WINDOWS, SERIES IIA AND III EXPORT ONLY

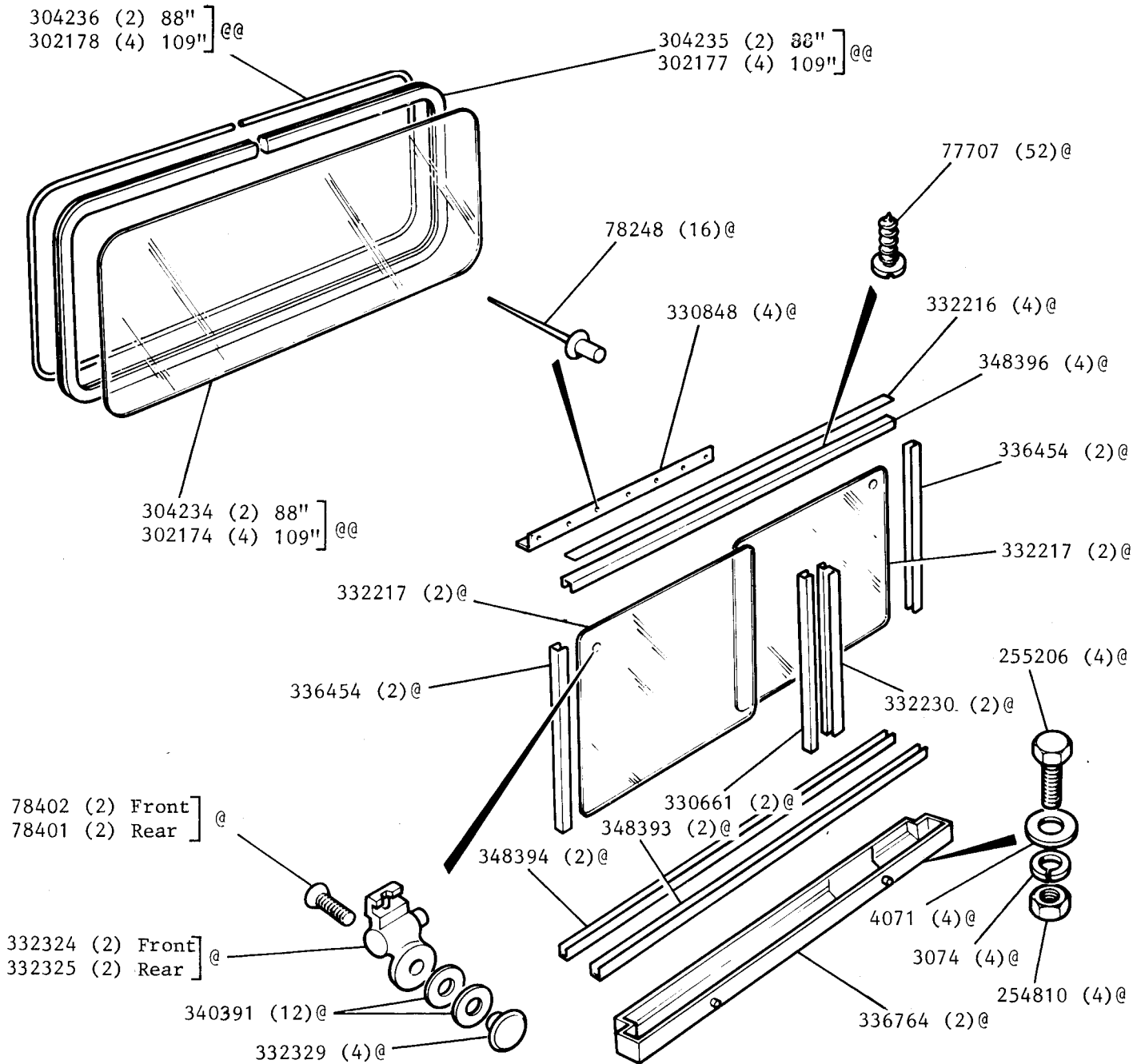

REMARKS

@ 88" Sliding Windows

@@ Fixed Windows

TRUCK CAB ROOF AND ROOF SEALS SERIES IIA AND III

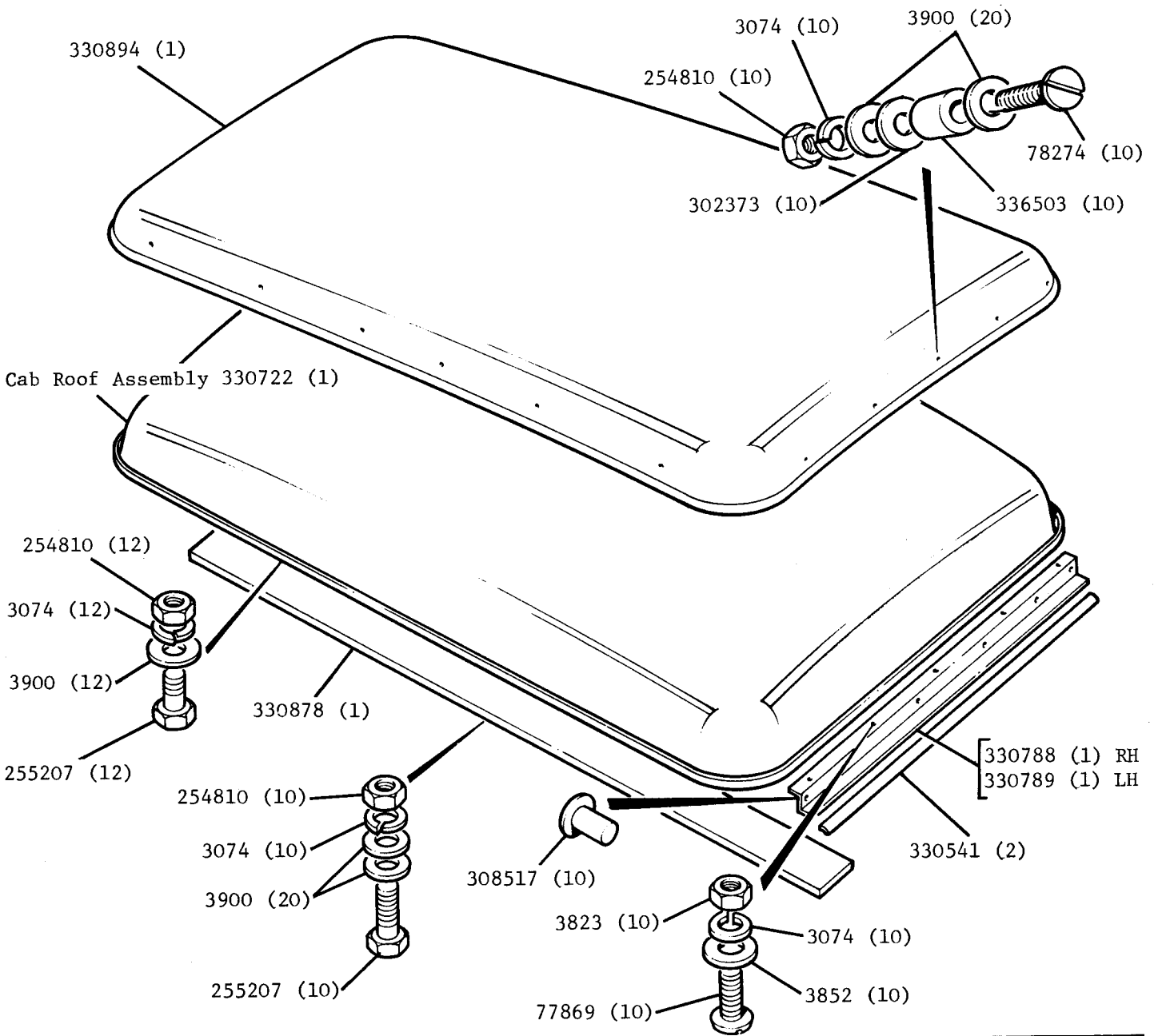

REMARKS

TRUCK CAB GLASS AND REAR PANEL SEALS SERIES IIA AND III

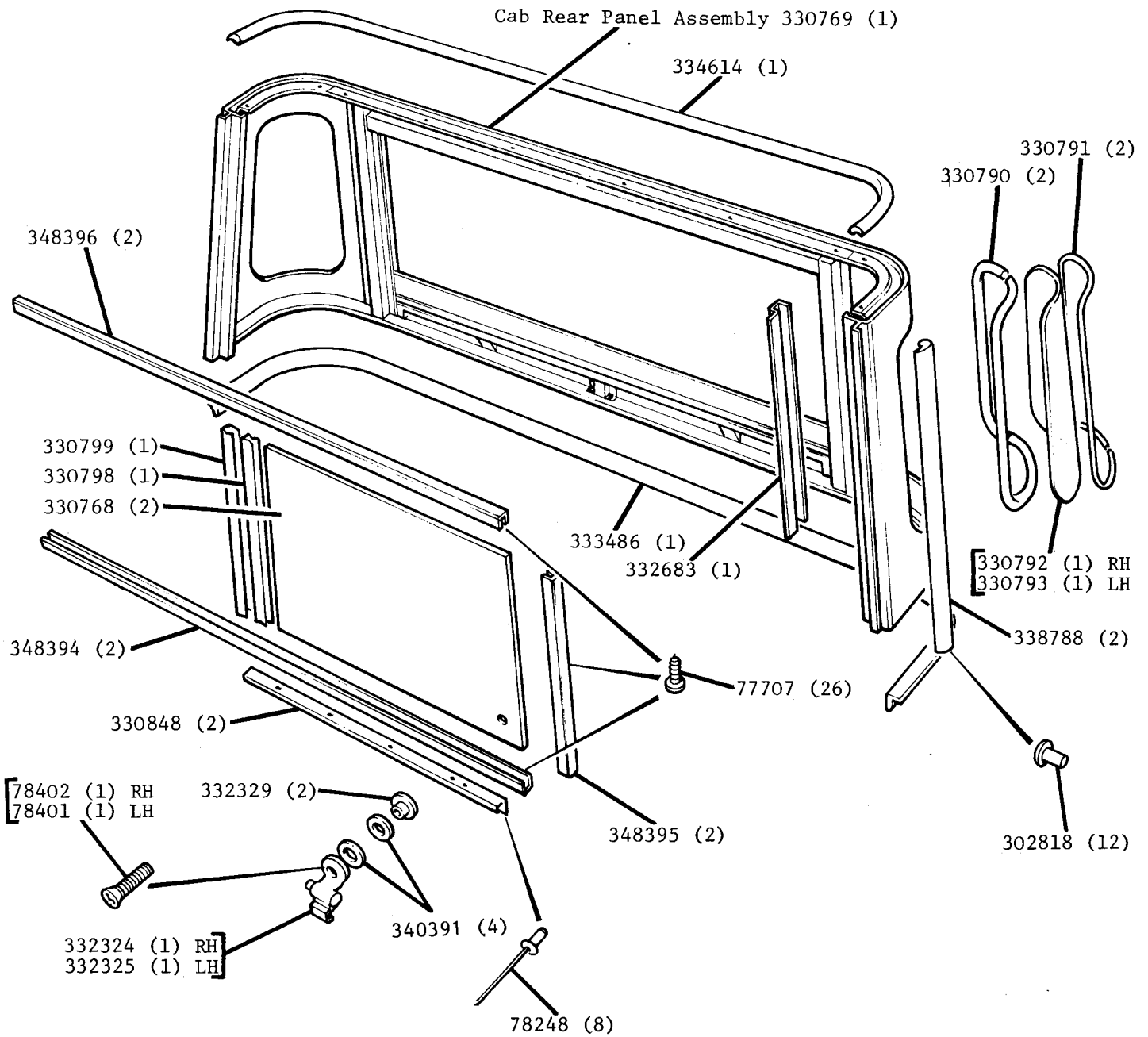

REMARKS

TRUCK CAB REAR PANEL FIXINGS SERIES IIA AND III

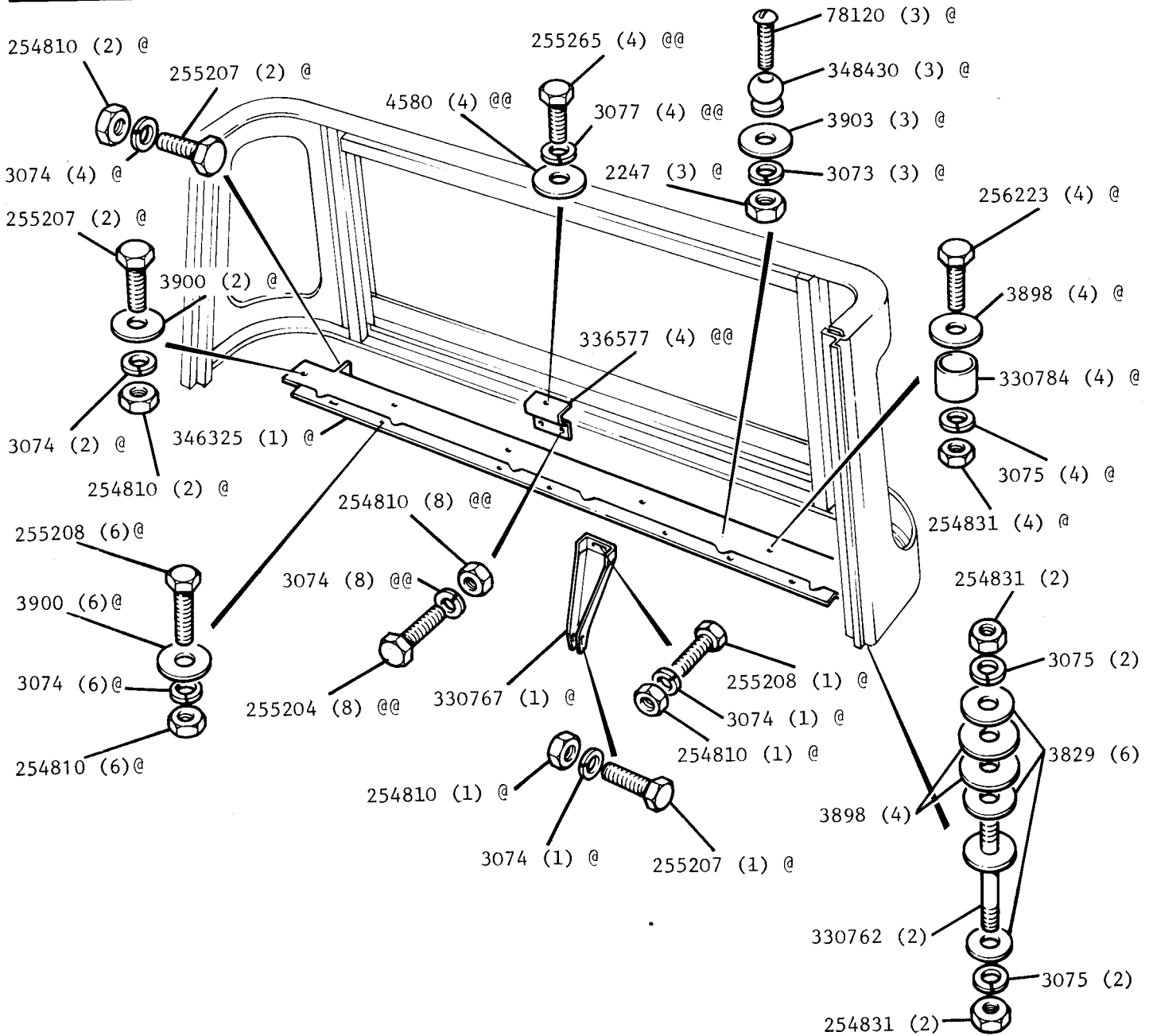

REMARKS

@ 88 in.

@@ 109 in.

FOLDING STEP FOR SIDE DOORS. SERIES 11A AND 111

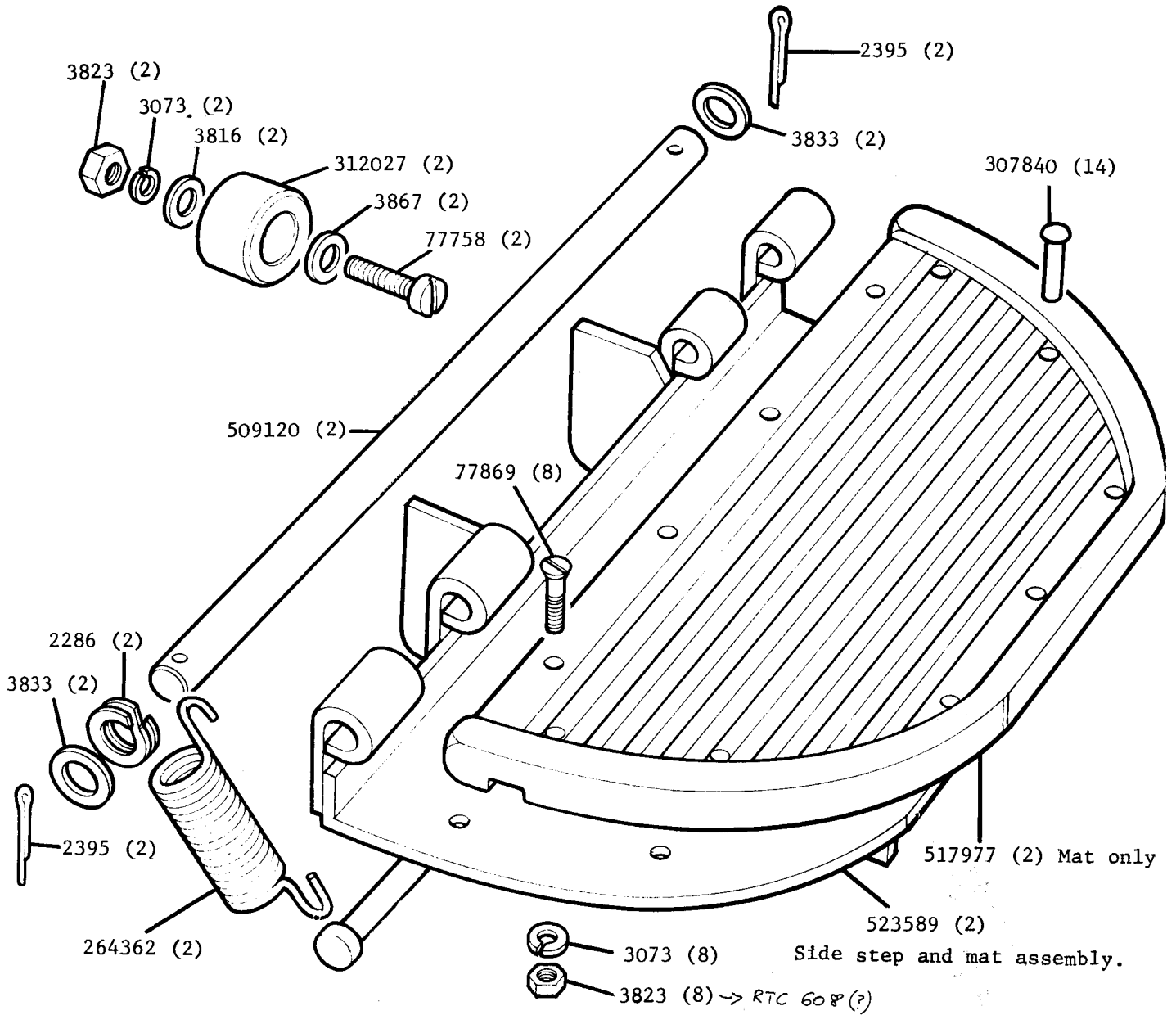

REMARKS

Folding Step For Side Door Complete Assembly 606002 (2) 88in and 109in. long  
 (4) 109in Station Wagon  
 Standard fitting on all 12 Seater Station Wagons, optional all others  
 Double quantities for the 109in Station Wagon

FOLDING STEP FOR SIDE DOORS, BRACKETS AND FIXINGS SERIES 11A AND 111

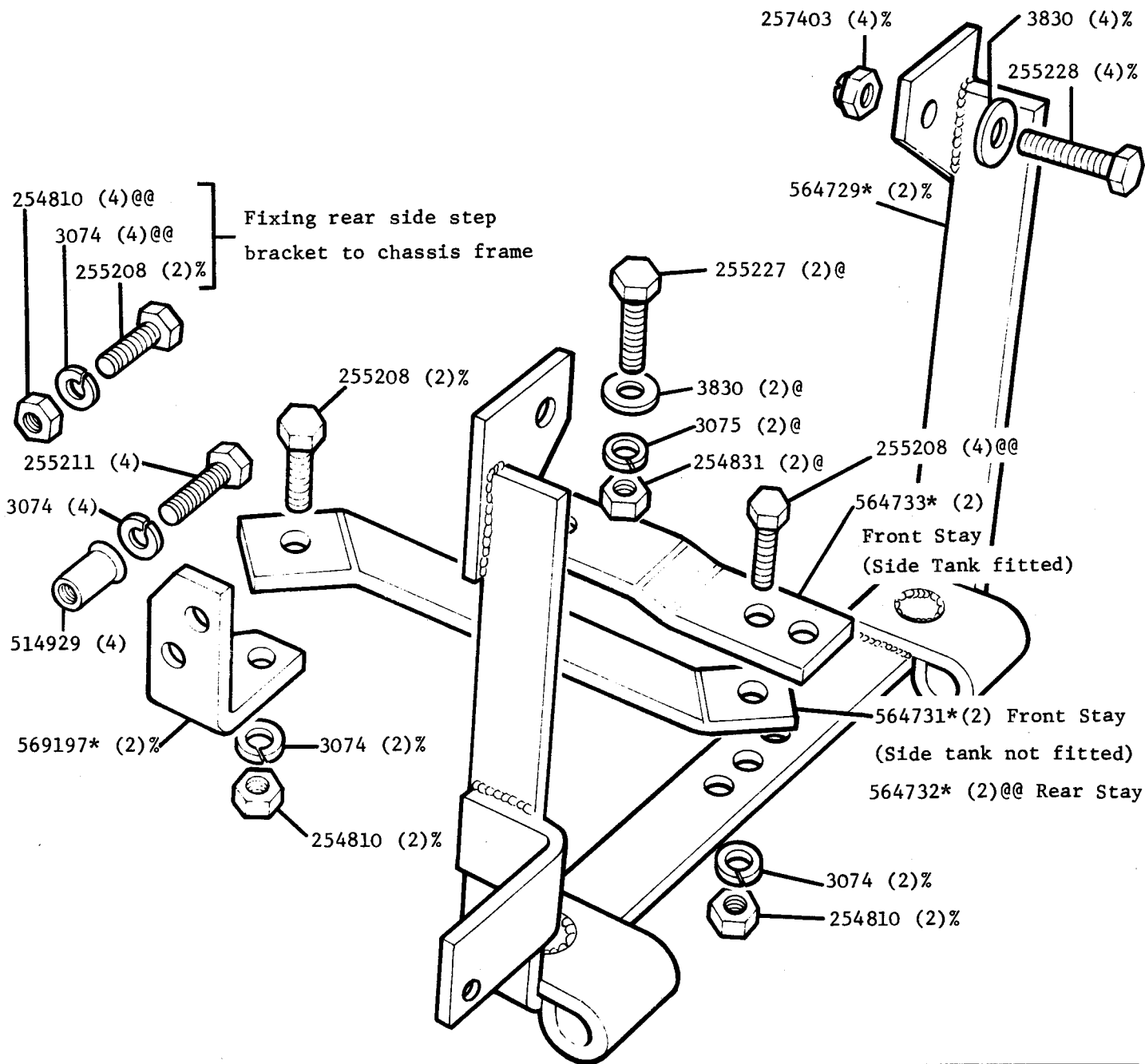

REMARKS

Folding Step For Side Door Complete Assembly 606002 (2)%  
 Standard fitting on all 12 Seater Station Wagons, Optional All others  
 @ 88in and 109in long  
 @@ 109in Station Wagon  
 % Double quantities on the 109in Station Wagon application



REAR FOLDING STEP. SERIES 11A AND 111

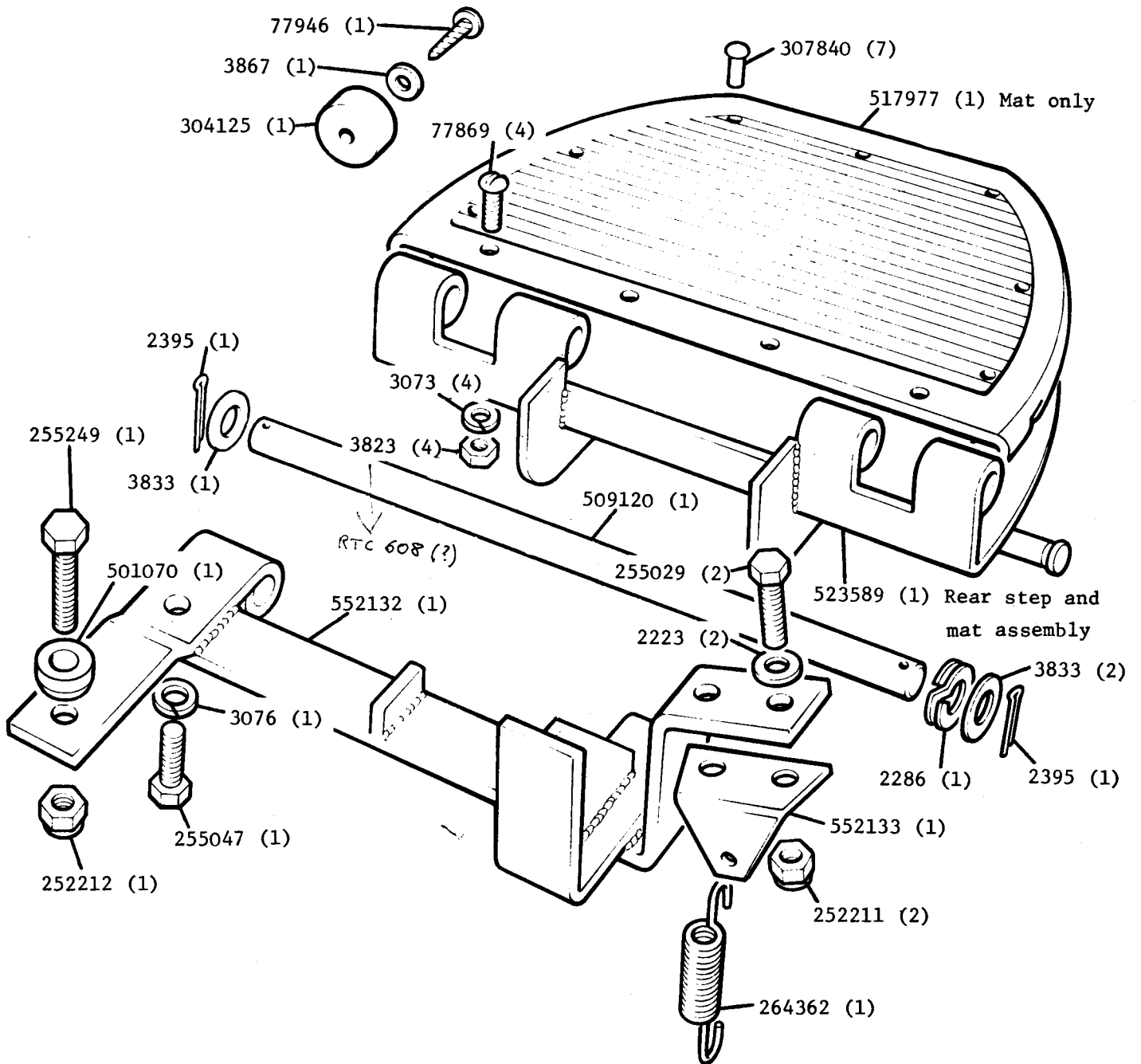

REMARKS

Rear Folding Step Assembly 605934 (1) All models except 88in and 109in Station Wagons.  
 Cannot be used in conjunction with Towing Plates 501683 and 606008

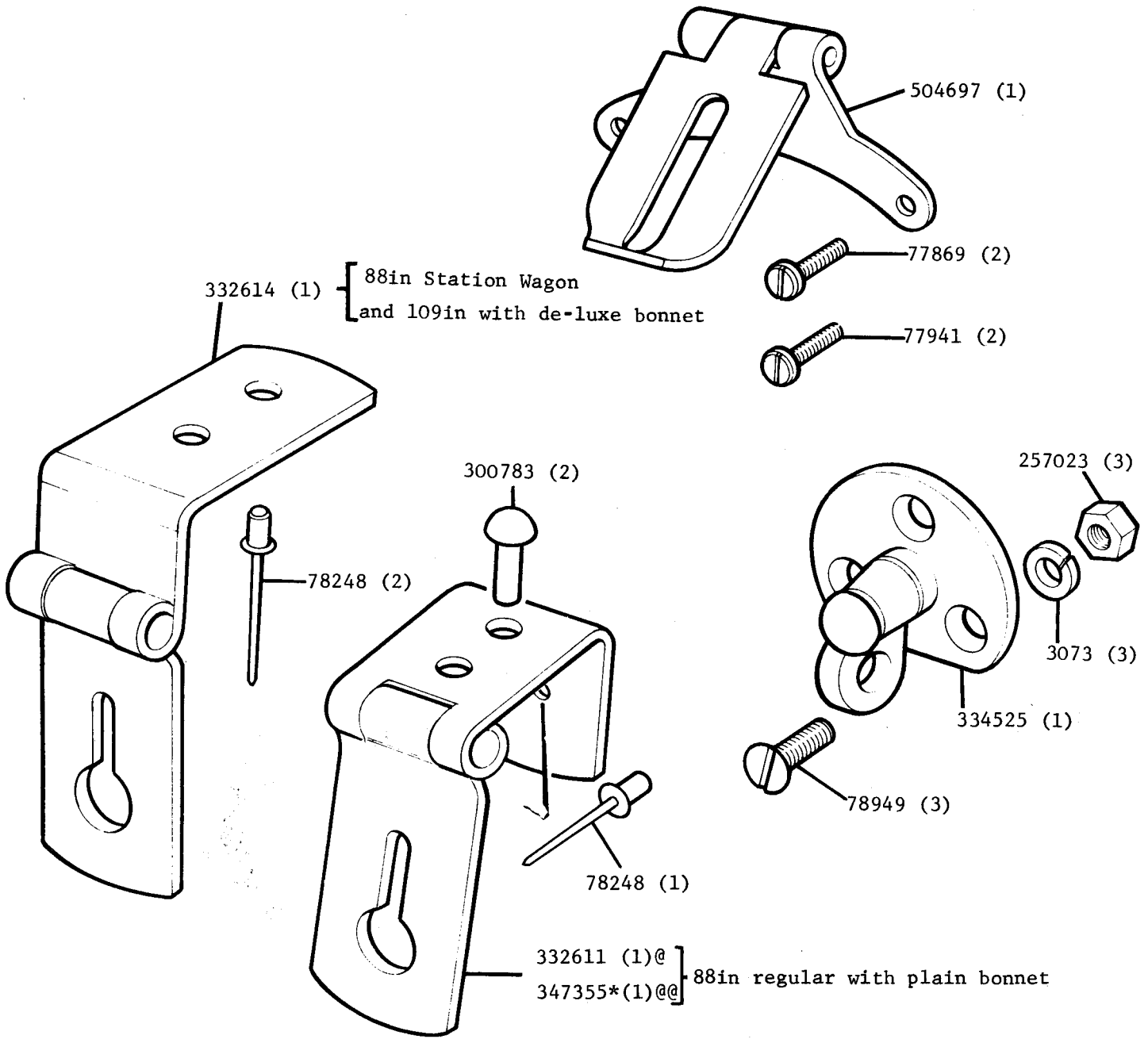

REMARKS

Bonnet locking Device For De-Luxe Bonnet 332969 (1) Except 88in Regular

Bonnet Locking Device For Plain Bonnet 332970 (1)@ } 88in Regular  
320824\* (1)@@ }

@ Series 11A

@@ Series 111

SUPPORT ASSEMBLY FOR SPARE WHEEL. SERIES IIA AND III 88" AND 109" EXCEPT 1 TON  
AND 109" VEHICLES FITTED WITH 9.00 x 15" OR 16" TYRES.

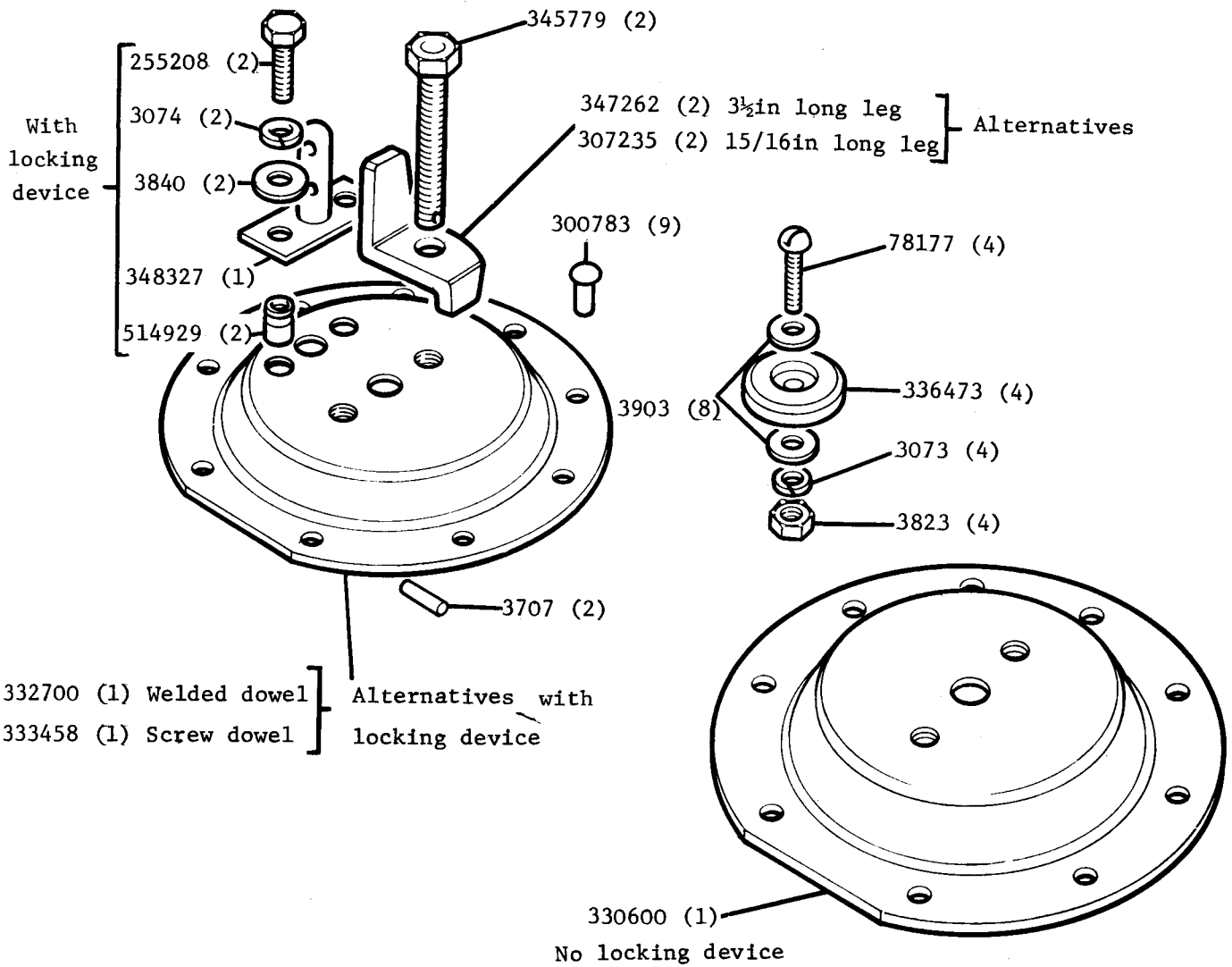

REMARKS

Support Assembly For Spare Wheel 330972 (1) No locking device

Support Assembly For Spare Wheel 88in 332971 (1) }  
 Support Assembly For Spare Wheel 109in 332972 (1) } With locking device

SUPPORT ASSEMBLY FOR SPARE WHEEL ON BONNET SERIES III 1 TON AND 109 in VEHICLES FITTED WITH 900 x 15 in OR 16 in TYRES

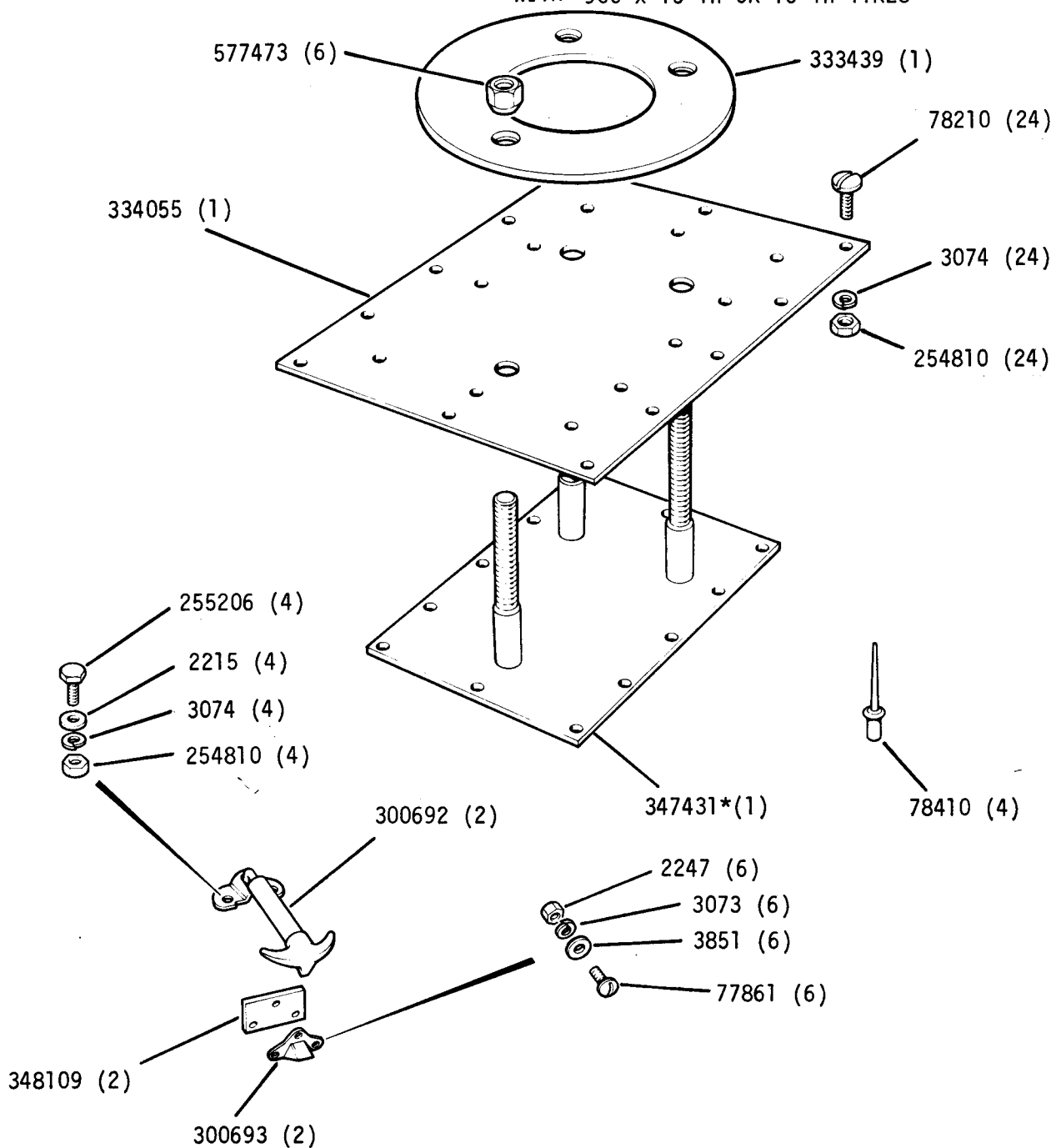

REMARKS  
 Support Assembly for Spare Wheel 607717 (1)

DE-LUXE FRONT OUTER AND DRIVER SEAT SERIES IIA AND III

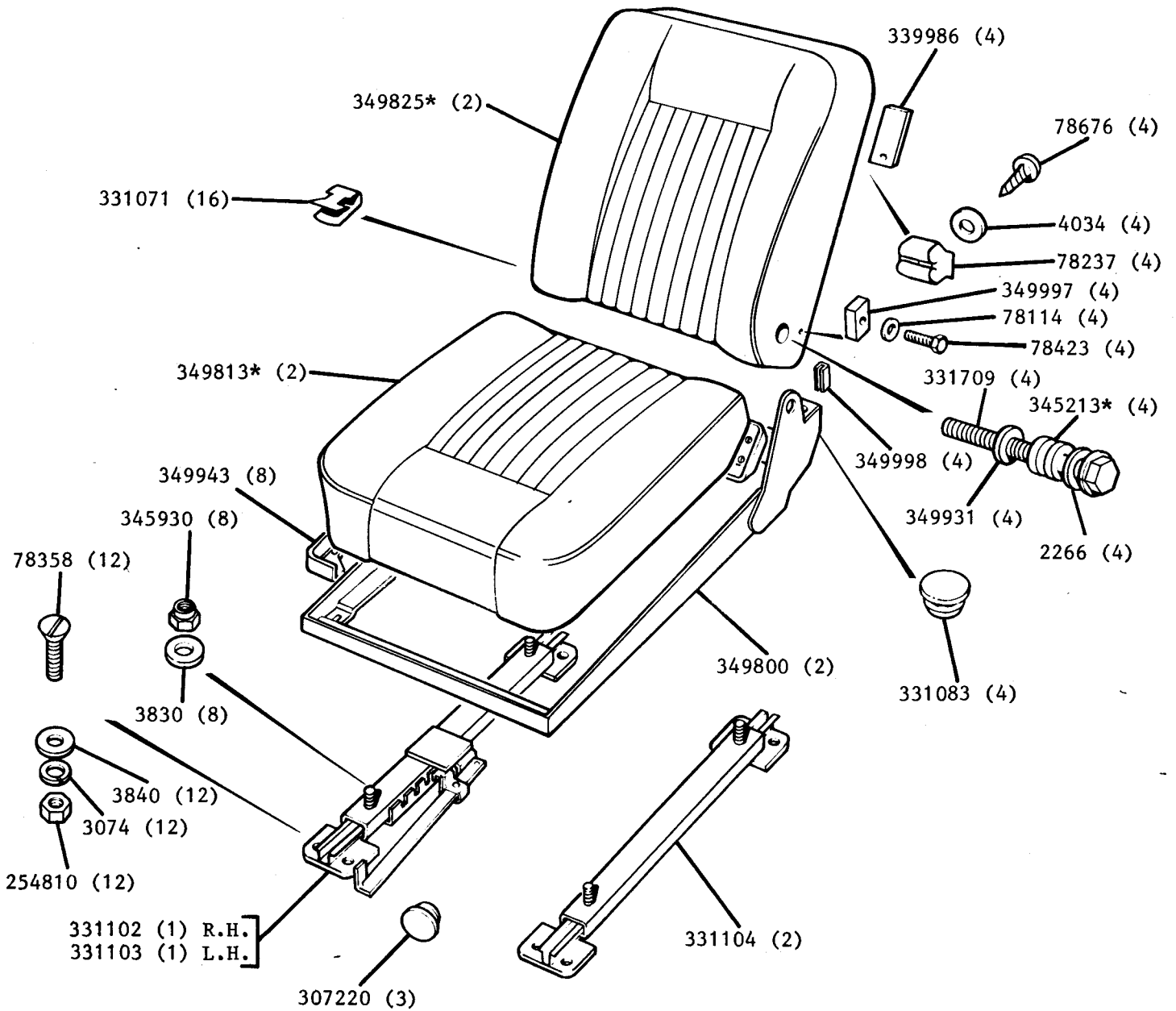

REMARKS

DE-LUXE FRONT CENTRE SEAT SERIES IIA AND III

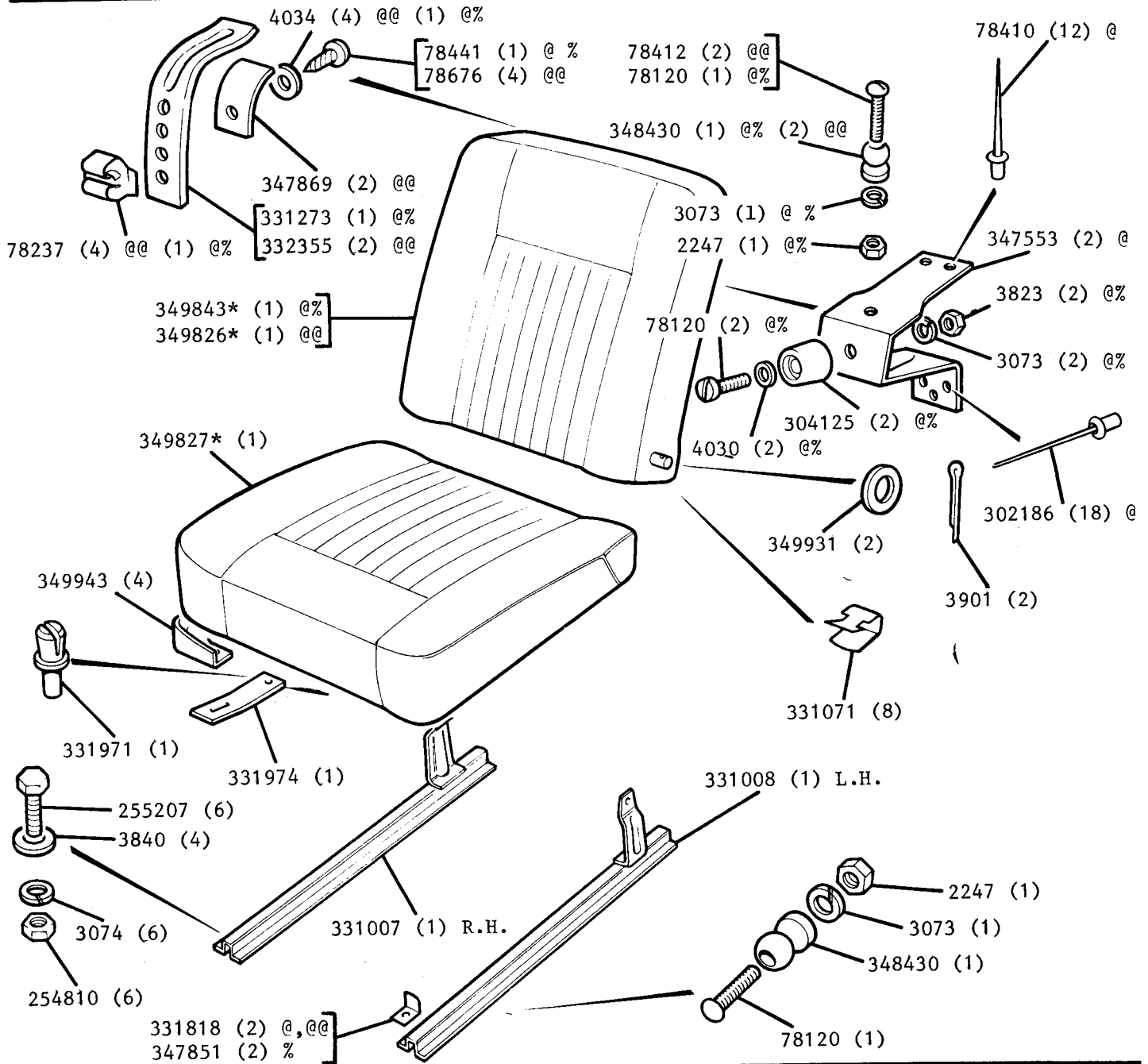

REMARKS

@ 109" long  
 @@ 109" Station Wagon  
 % 88"

REAR SEATS, SERIES IIA AND III

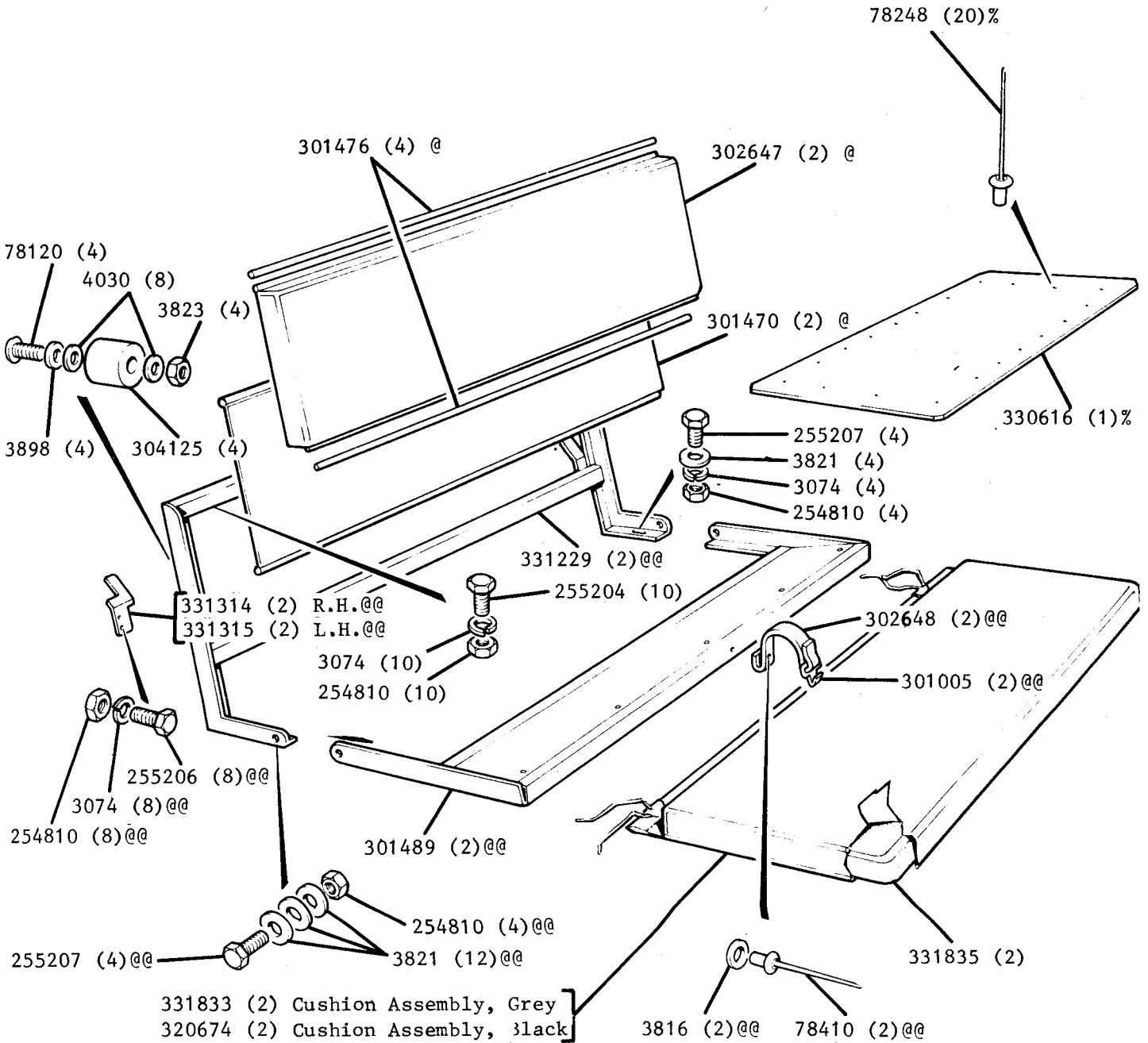

REMARKS

Rear Seat Complete Assembly, Grey, 330969 (2)  
 Rear Seat Complete Assembly, Black, 320737 (2)  
 Backrest Assembly, Grey 320084 (2)  
 Backrest Assembly, Black 320673 (2) } Items marked @ are part of these assemblies.  
 Seat Frame Complete Assembly, 331228 (2) Items marked @@ are part of this assembly.  
 % 109 in with 4 seats  
 The quantities on this frame are for 2 seats as fitted to 88" models.  
 109" models fitted with 4 seats should double the above quantities.

HARD TOP ROOF TRIM, SERIES IIA AND III 88"

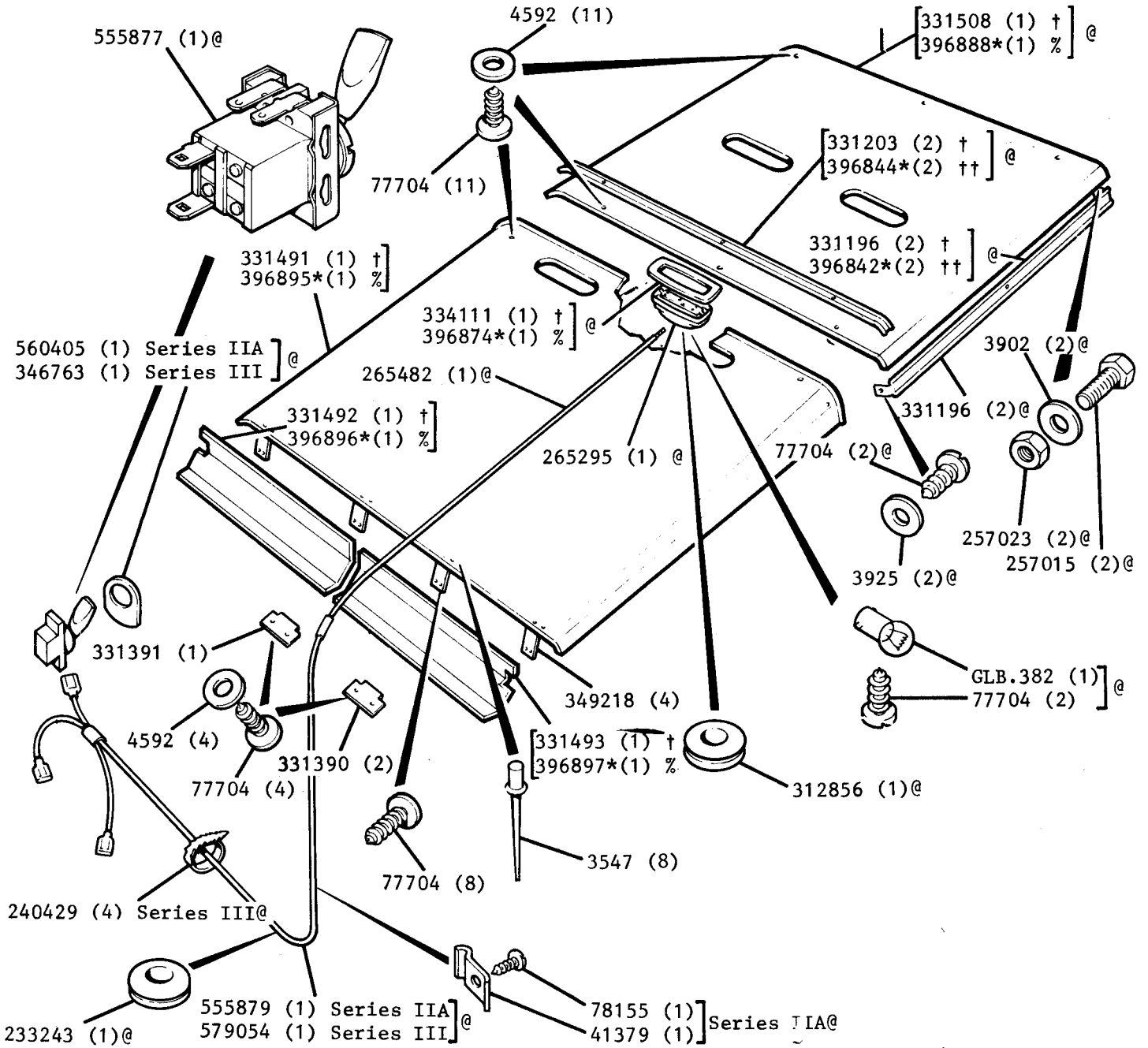

REMARKS

- @ Station Wagon Type Roof Only.
- † White
- †† Limestone
- % Oatmeal



HARD TOP ROOF TRIM, SERIES IIA AND III 109"

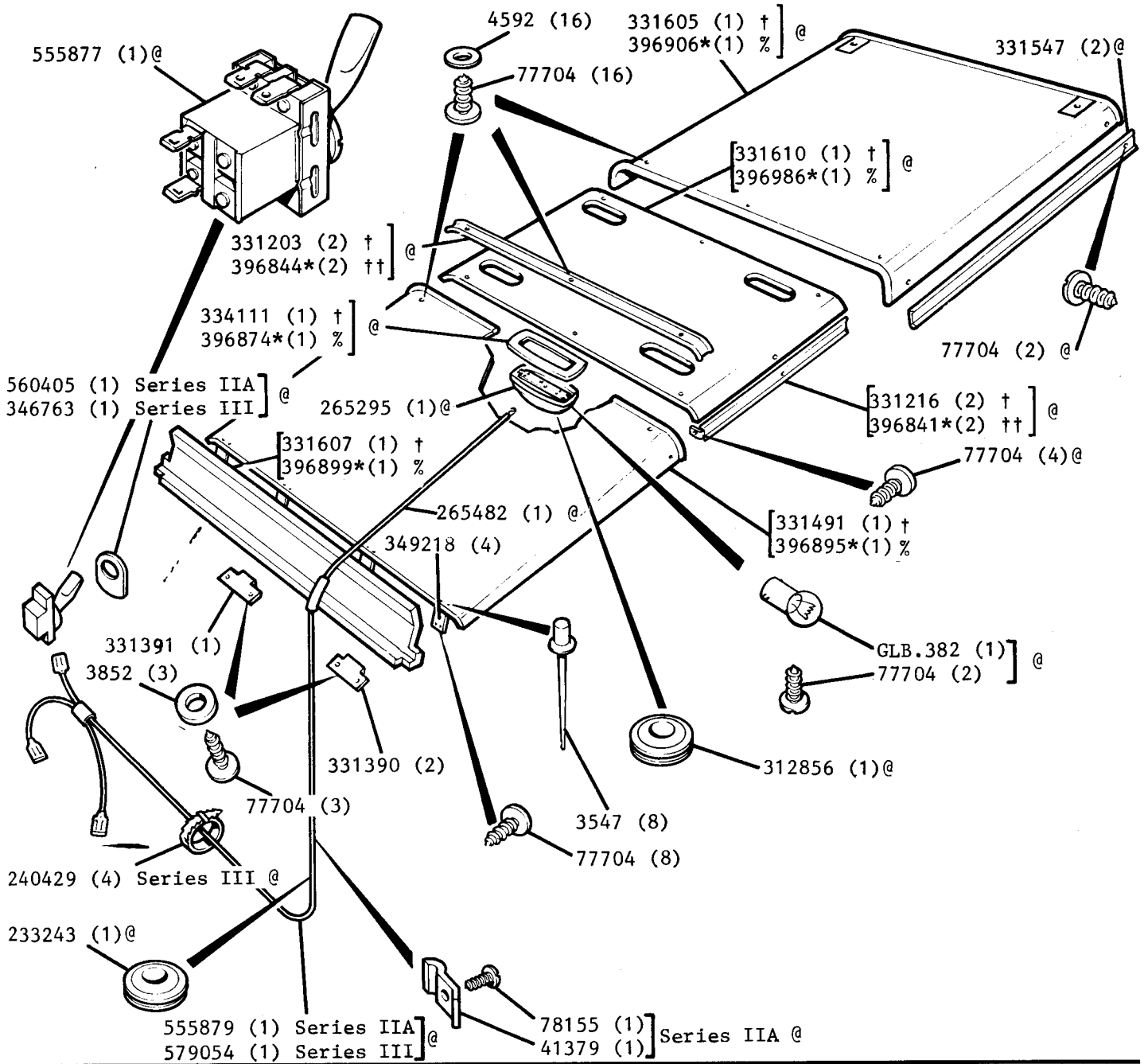

REMARKS

@ Station Wagon Type Roof Only.

† White

†† Limestone

% Oatmeal

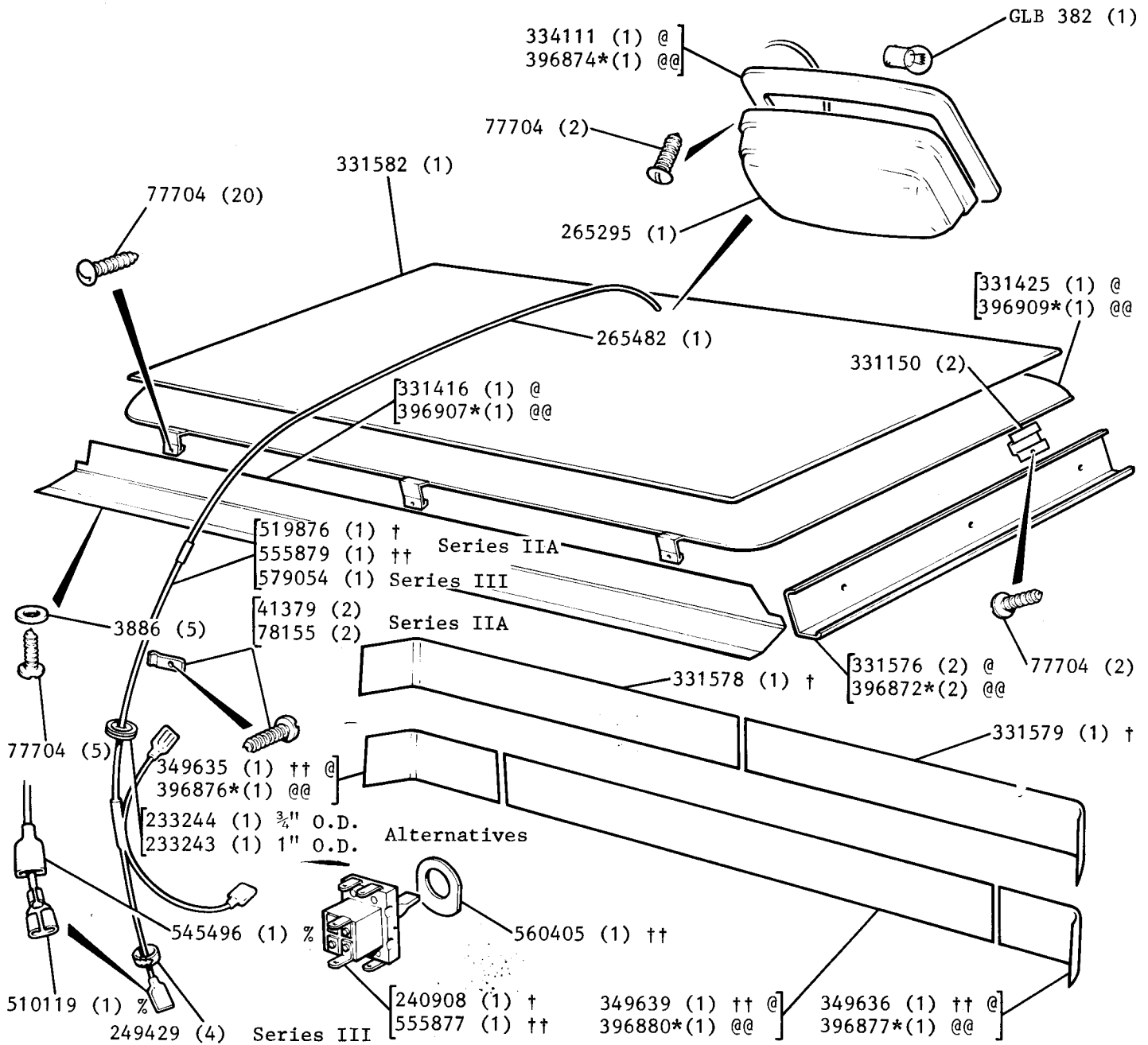

REMARKS

- Truck Cab Upper Trim Kit 332956 (1) †
- Truck Cab Upper Trim Kit 320624 (1) †† @
- Truck Cab Upper Trim Kit 320895\*(1) @@
- @ White trim
- @@ Oatmeal trim
- † Up to vehicle suffix 'C' inclusive
- †† From vehicle suffix 'D' onwards
- % For L.H. Stg vehicles the cable is cut to length and these items fitted

TRUCK CAB REAR PANEL TRIM, SERIES IIA AND III

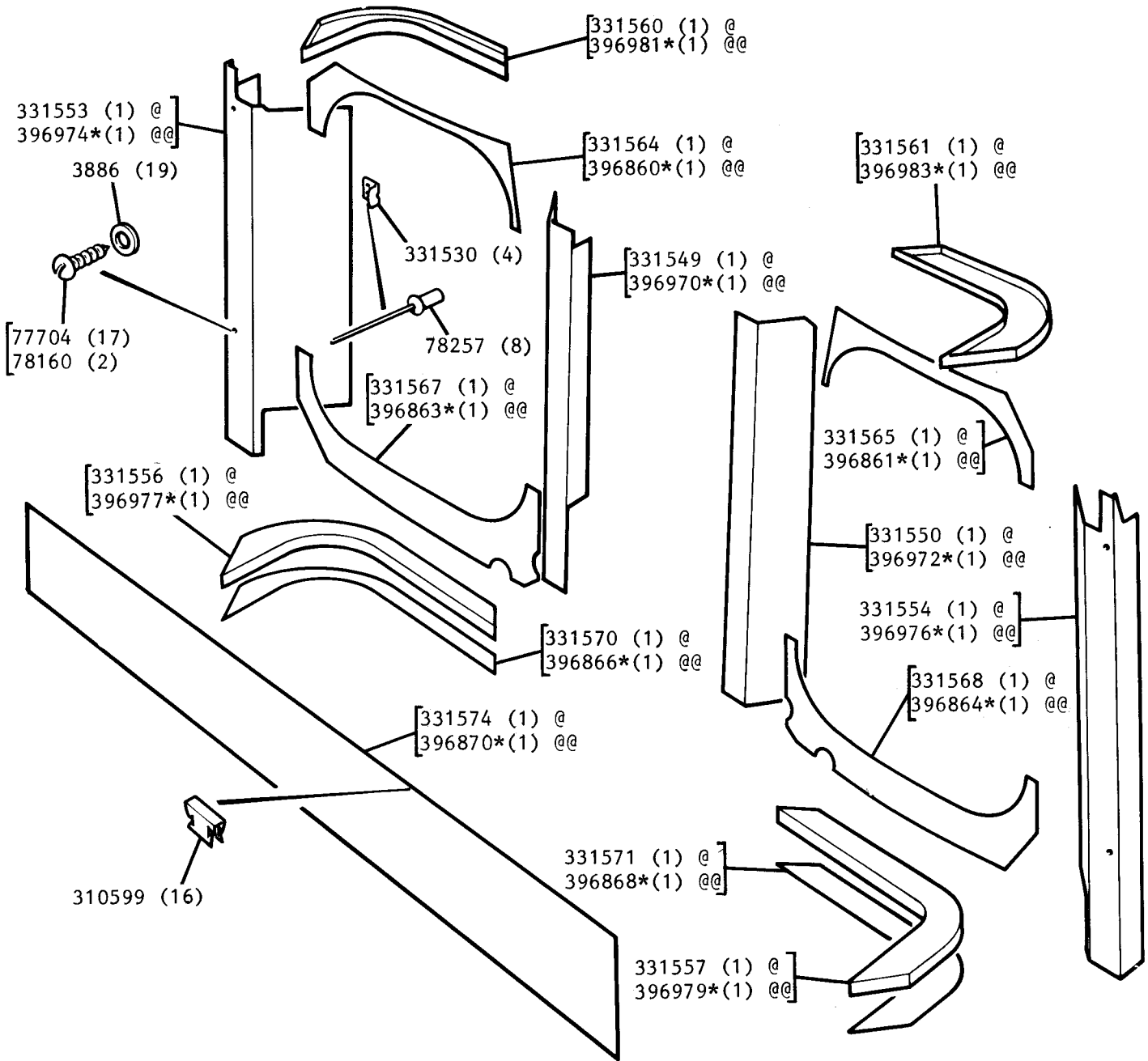

REMARKS

Truck Cab Upper Trim Kit 332956 (1) Up to vehicle suffix 'C' inclusive ] @  
 Truck Cab Upper Trim Kit 320624 (1) From vehicle suffix 'D' onwards ] @  
 Truck Cab Upper Trim Kit 320895\*(1) @@  
 @ White  
 @@ Oatmeal

DOOR TRIM FOR FLOOR AND DOOR TRIM, SERIES IIA

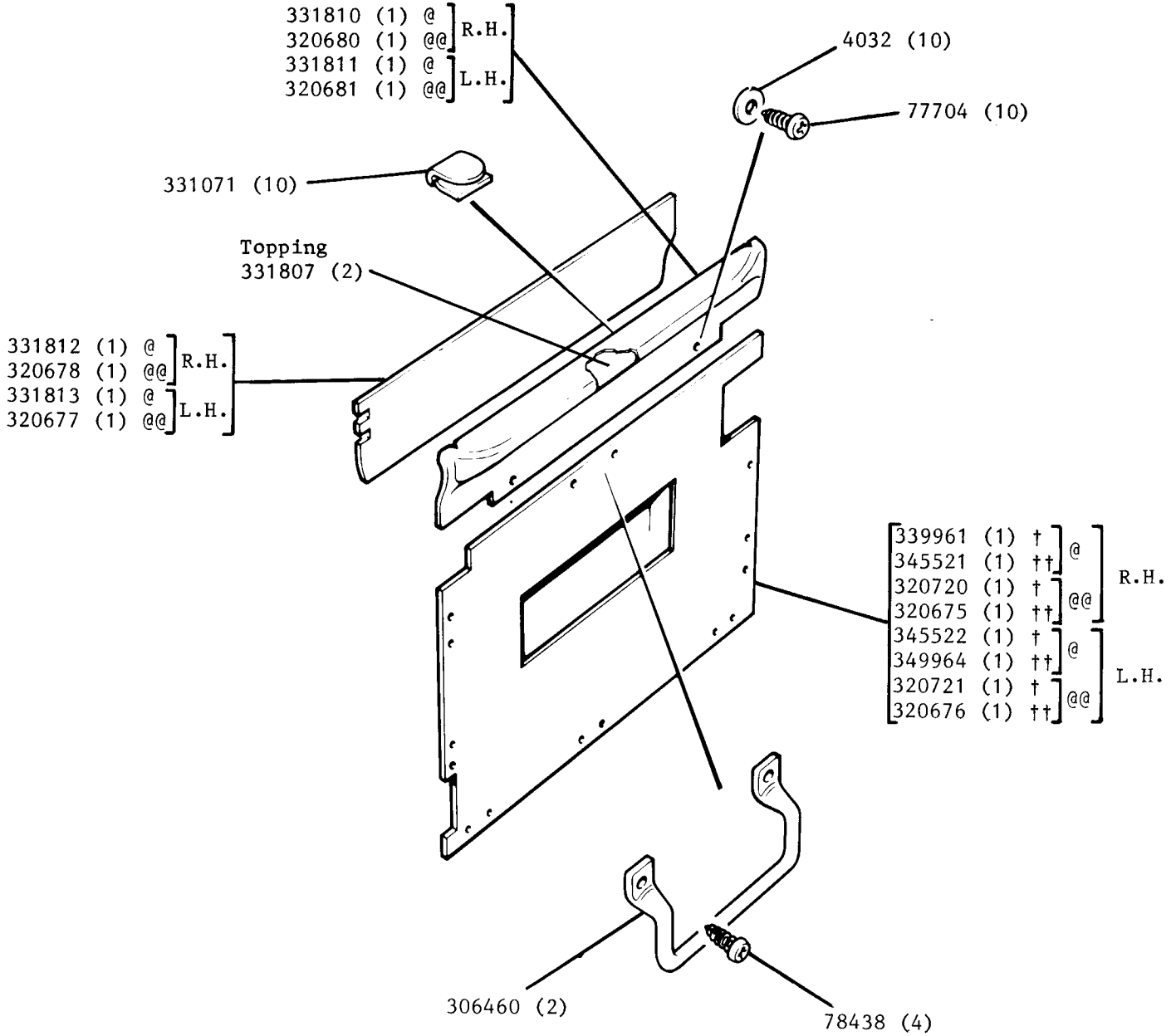

REMARKS

- @ Grey
- @@ Black
- † R.H. Stg
- †† L.H. Stg

Floor and Door Trim Kit 332958	(1)	@	} 2 1/4		
Floor and Door Trim Kit 320731	(1)	@@		†	
Floor and Door Trim Kit 332986	(1)	@			
Floor and Door Trim Kit 320732	(1)	@@		††	
Floor and Door Trim Kit 320660	(1)	@			
Floor and Door Trim Kit 320733	(1)			Up to vehicle suffix F inclusive	
Floor and Door Trim Kit 606281	(1)			From vehicle suffix G onwards	
Floor and Door Trim Kit 320661	(1)	@			
Floor and Door Trim Kit 320734	(1)			Up to vehicle suffix F inclusive	
Floor and Door Trim Kit 606282	(1)			From vehicle suffix G onwards	
					@@ } † } 2.6
					@@ } †† }

DOOR TRIM FOR FLOOR AND DOOR TRIM, SERIES III

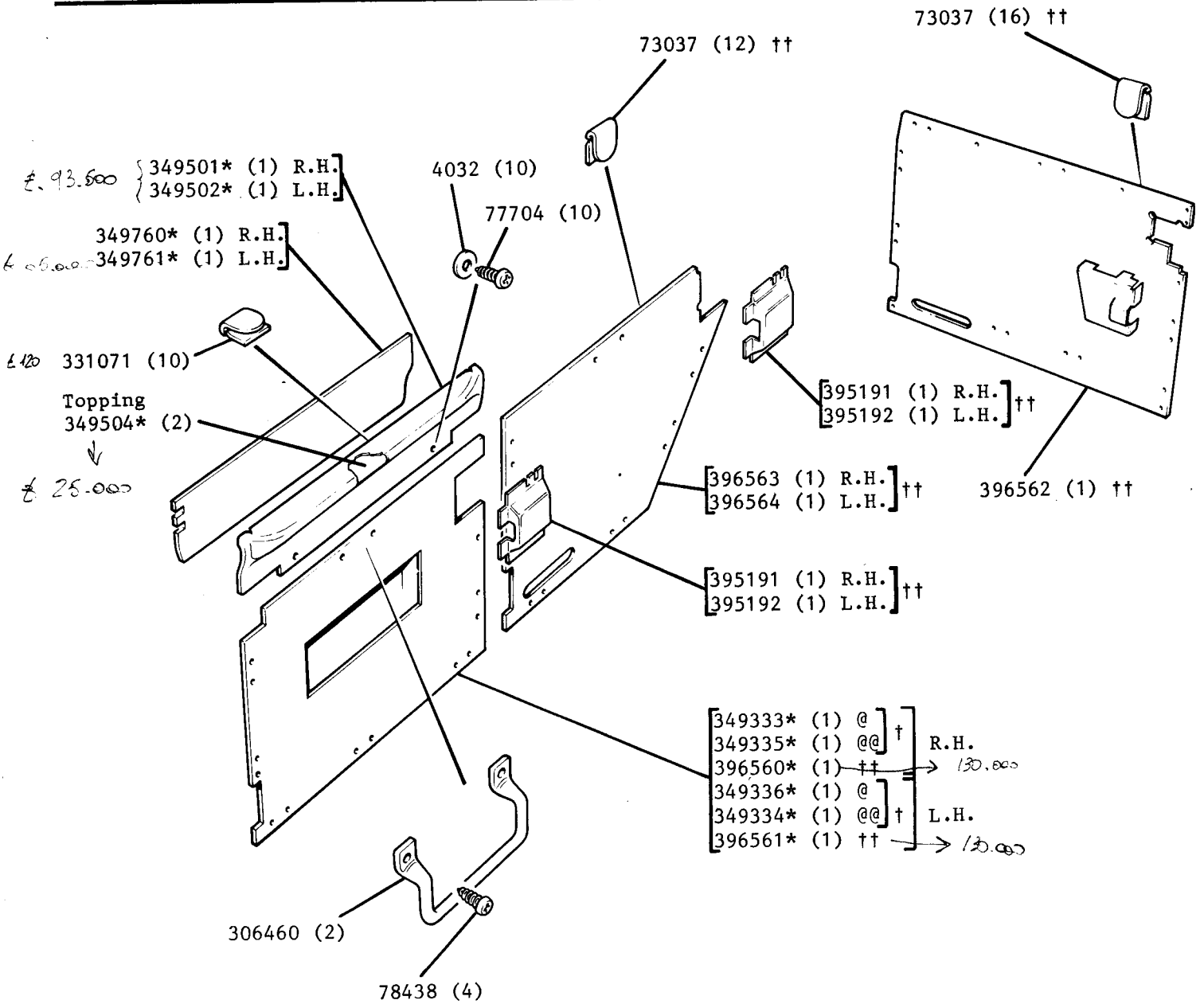

REMARKS

@ R.H. Stg

@@ L.H. Stg

† Series III without anti-burst door locks

†† Series III with anti-burst door locks

Floor and Door Trim Kit 320764 (1) @ ] 2.4  
 Floor and Door Trim Kit 320765 (1) @@ ]  
 Floor and Door Trim Kit 320761 (1) @ ] 2.6  
 Floor and Door Trim Kit 320762 (1) @@ ]

DASH COVERING FOR FLOOR AND DOOR TRIM, SERIES IIA AND III

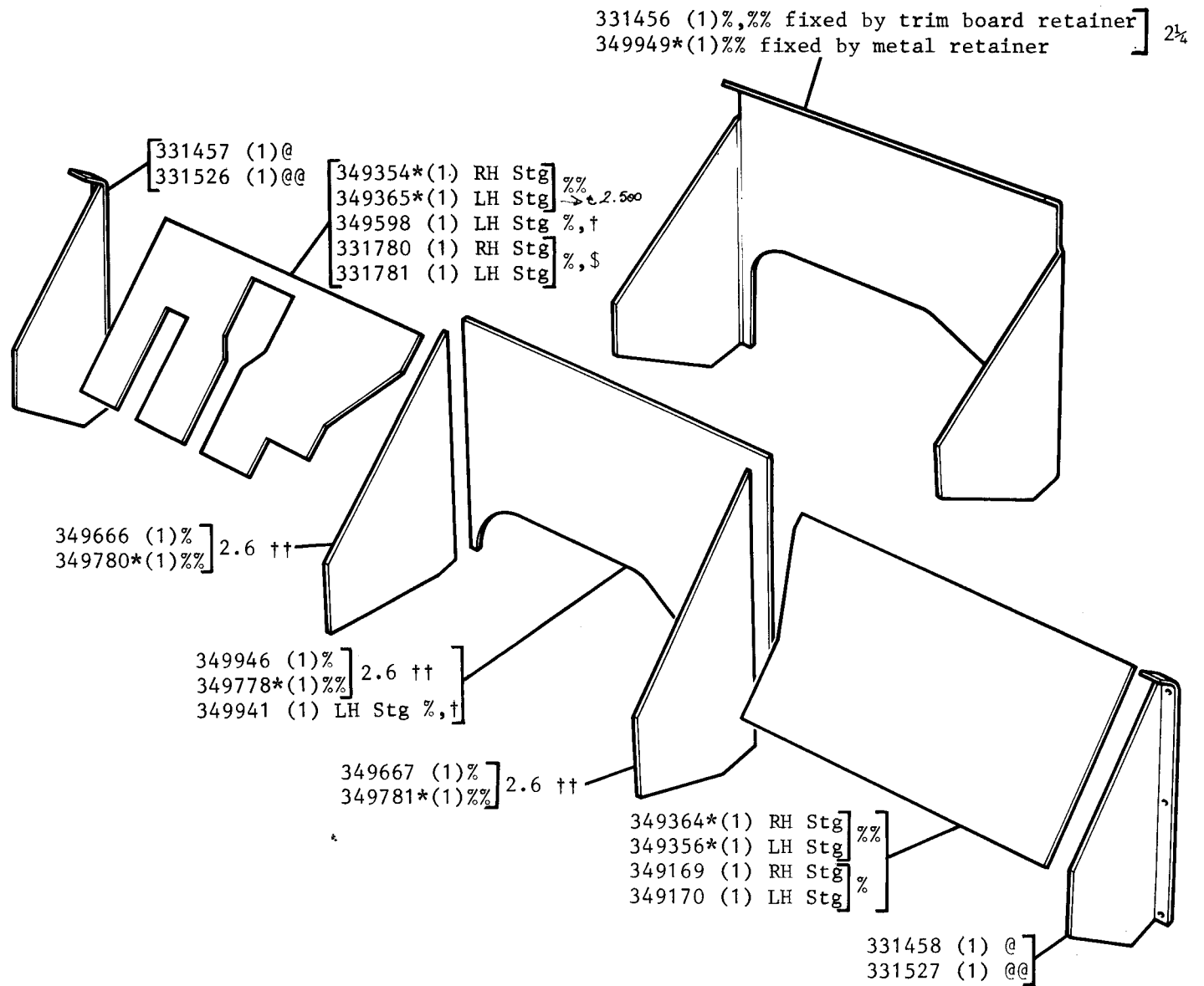

REMARKS

- @ All except Series IIA LH Stg models
- @@ Series IIA LH Stg models
- † With fresh air heater
- †† No fresh air heater
- % Series IIA
- %, % Series III
- \$ 2.6 up to vehicle suffix 'F' inclusive and 2 1/4

GEARBOX COVER AND FRONT FLOOR MATS FOR FLOOR AND DOOR TRIM      SERIES IIA AND III

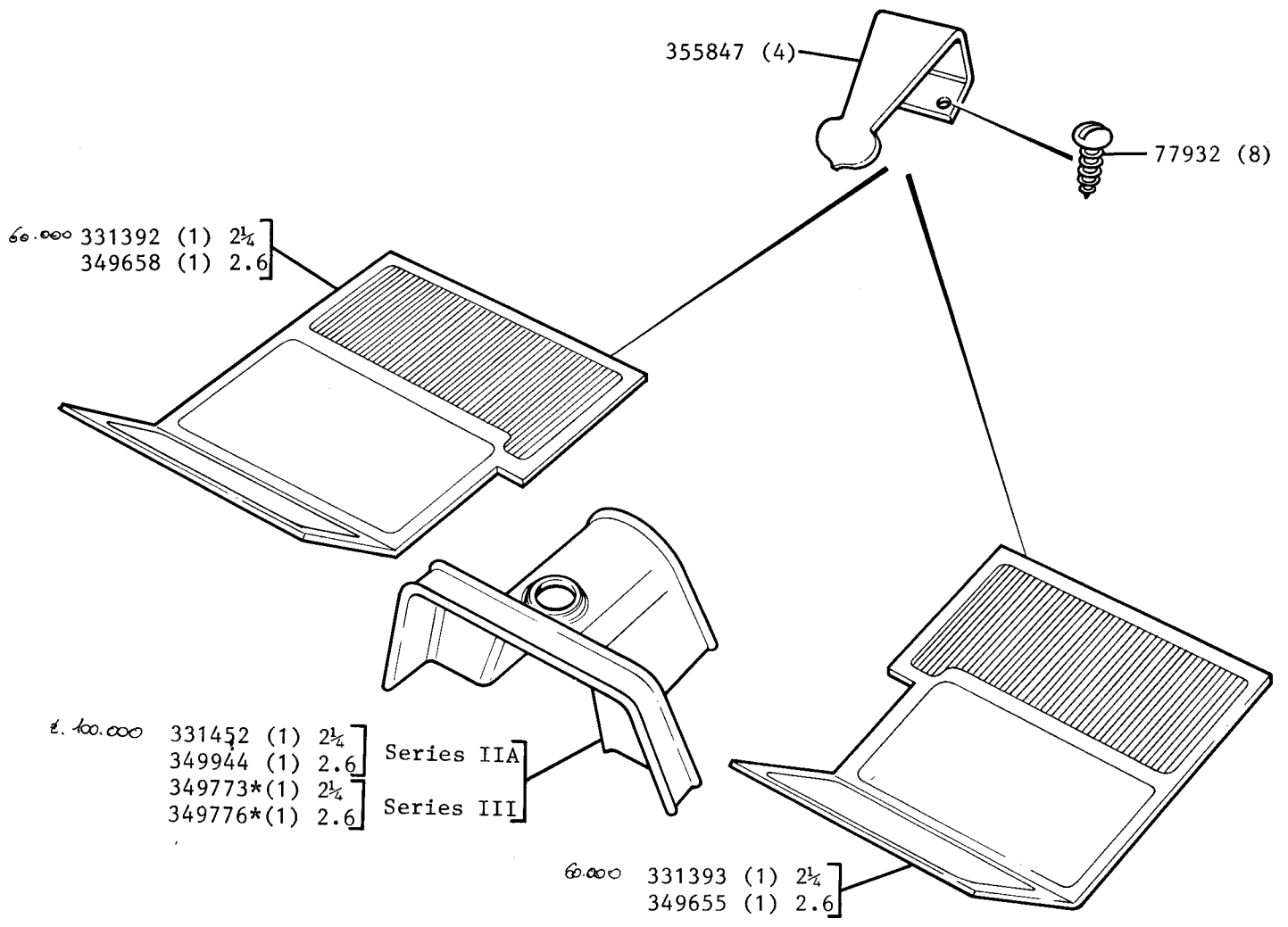

REMARKS

RETAINERS FOR FLOOR AND DOOR TRIM, SERIES IIA AND III

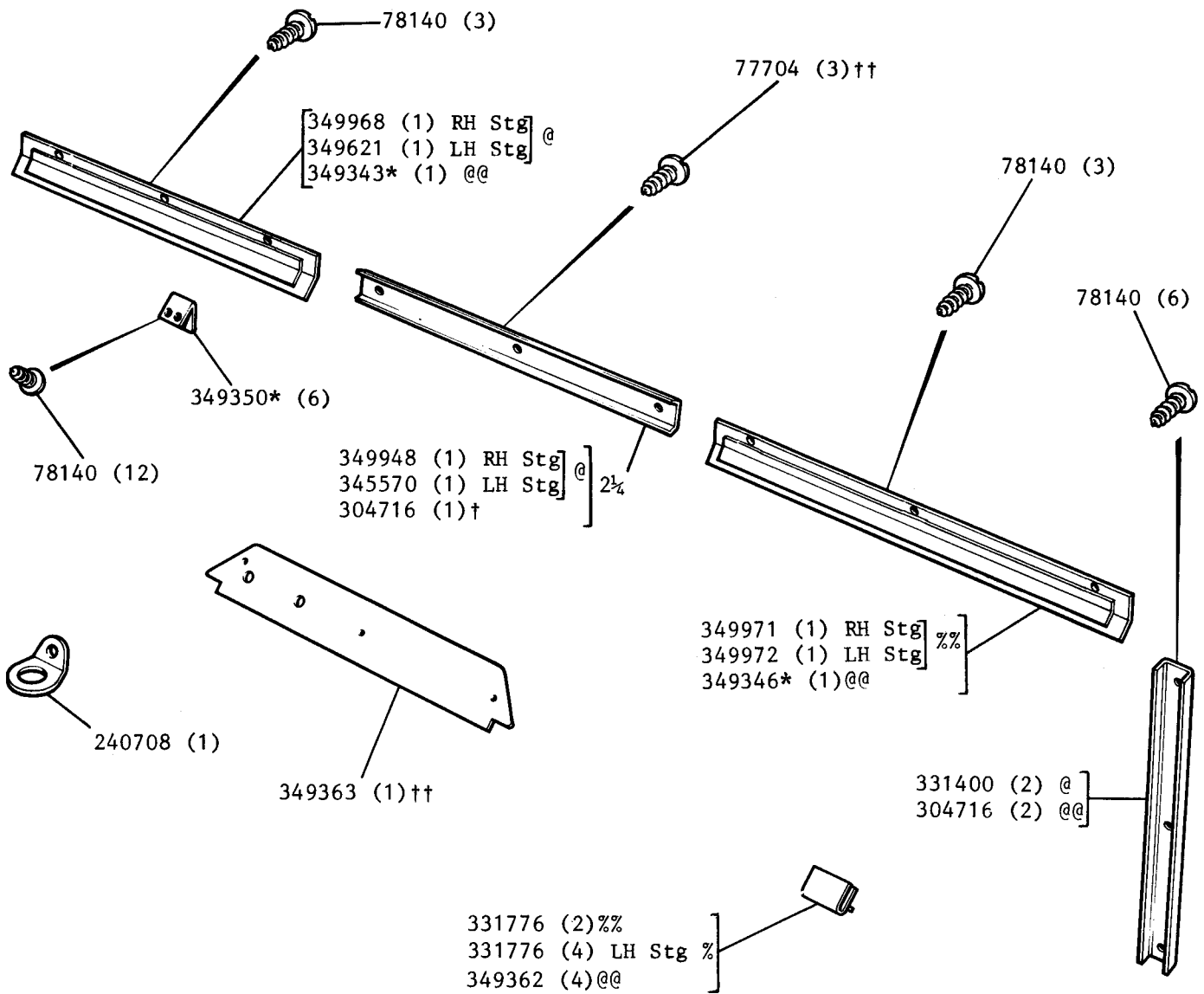

REMARKS

- @ Series IIA
- @@ Series III
- % Series IIA Fitted with fresh air heater
- %% Series IIA no fresh air heater fitted
- † 2½ with metal retainer
- †† 2½ with trim board retainer



INTERIOR SUN VISOR AND INTERIOR DRIVING MIRROR, PLAIN AND SNAP STEM TYPE. SERIES IIA AND III.

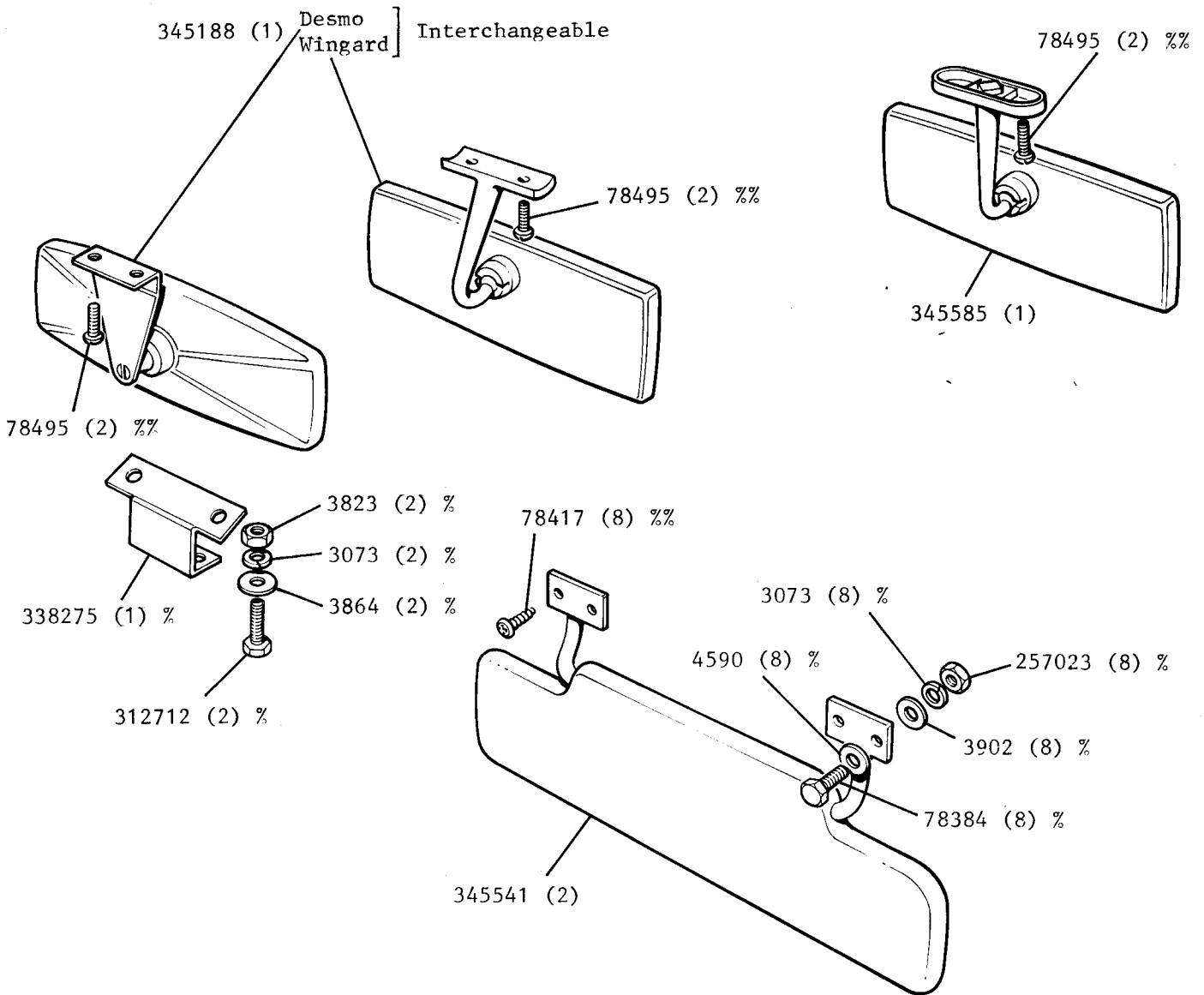

REMARKS

Interior Sun Visor Kit 320849\* (1)  
 Interior Mirror Kit 320833\* (1)  
 Standard fitting for all Station Wagons, Home and Export, all Export Hard Tops and Cabs  
 excluding Holland and Sweden.  
 Interior Mirror, Snap Stem, Kit. 320834\* (1)  
 Standard fitting for French, German and U.S.A. vehicles  
 % Untrimmed vehicles  
 %% De-luxe trimmed vehicles

FRONT SAFETY HARNESS ANCHORAGES, PART I SERIES IIA AND III

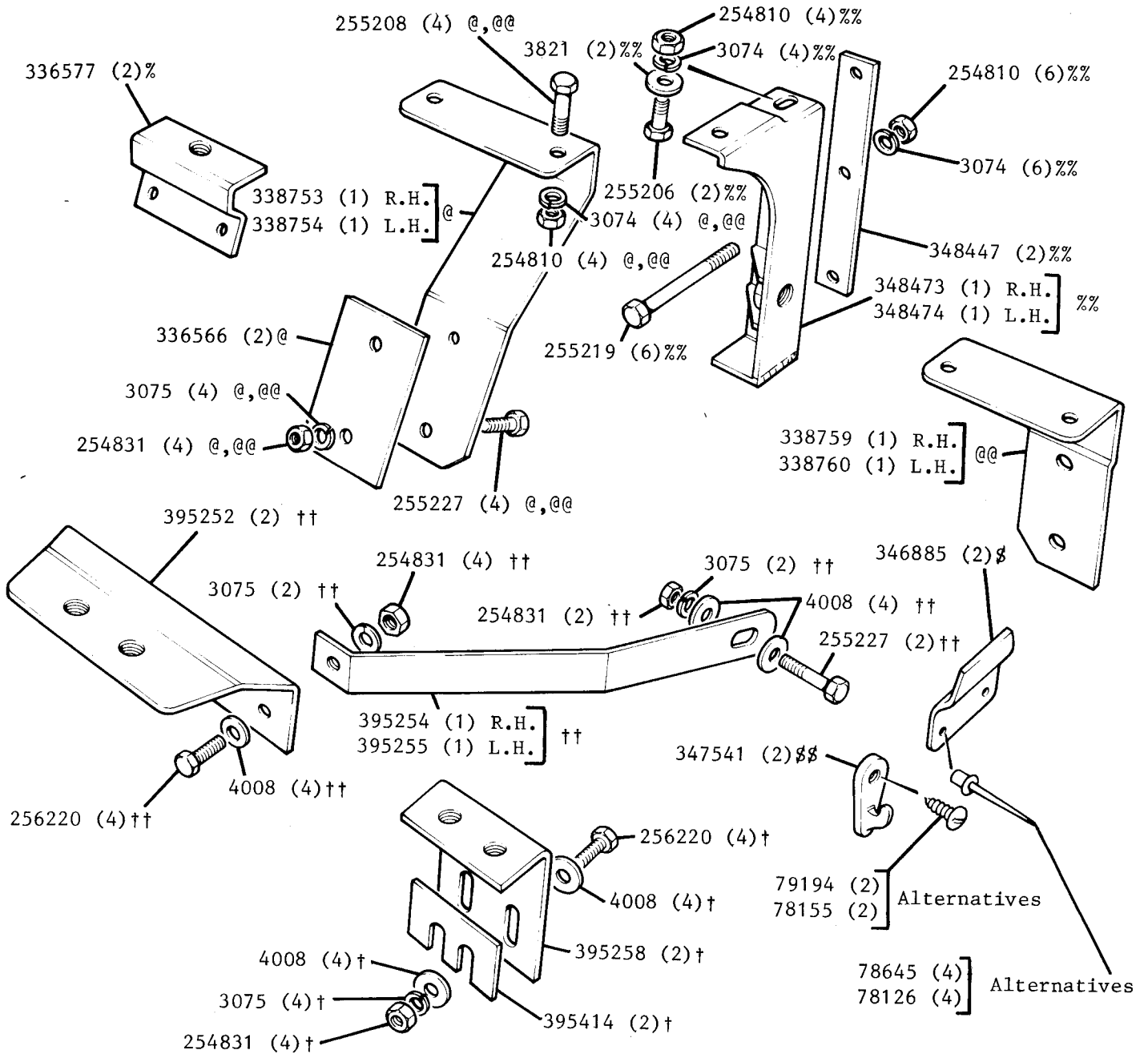

REMARKS

- @ 88" Without Truck Cab
  - @@ 109" With Full Hood or Hard Top } Up to vehicle Suffix 'D'
  - % 109" With Truck Cab
  - %% 109" Station Wagon. Up to July 1972
  - § For Irvin Safety Harness
  - §§ For Britax Safety Harness
  - † 88" } From August 1972
  - †† 109" }
- |  |   |  |  |
|--|---|--|--|
| Anchorage Kit R.H. 320631 (1)<br>Anchorage Kit L.H. 320632 (1) | @ | Anchorage Kit R.H. 320639 (1)<br>Anchorage Kit L.H. 320640 (1) | 109" Station Wagon up to<br>vehicle suffix 'D' |
| Anchorage Kit R.H. 320633 (1)<br>Anchorage Kit L.H. 320634 (1) | @ | and with Truck Cab   |  |

FRONT SAFETY HARNESS ANCHORAGES, PART II SERIES IIA AND III

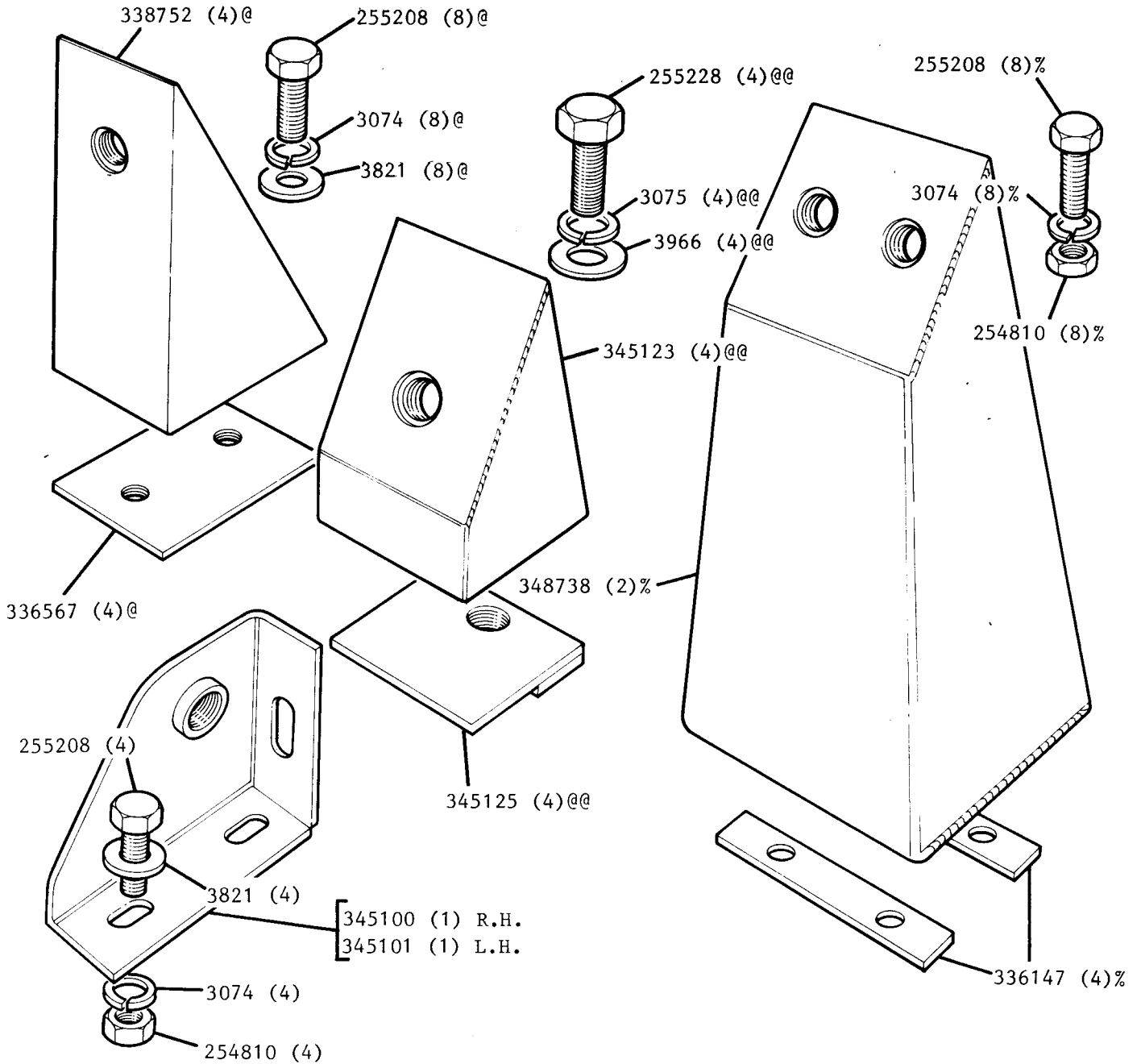

REMARKS

@ 88" )  
 @@ 109" Except Station Wagon ) Up to July 1972  
 % 109" Station Wagon up to vehicle suffix 'D'

EXTERIOR SUN VISOR AND FRONT BUMPERETTES SERIES IIA AND III

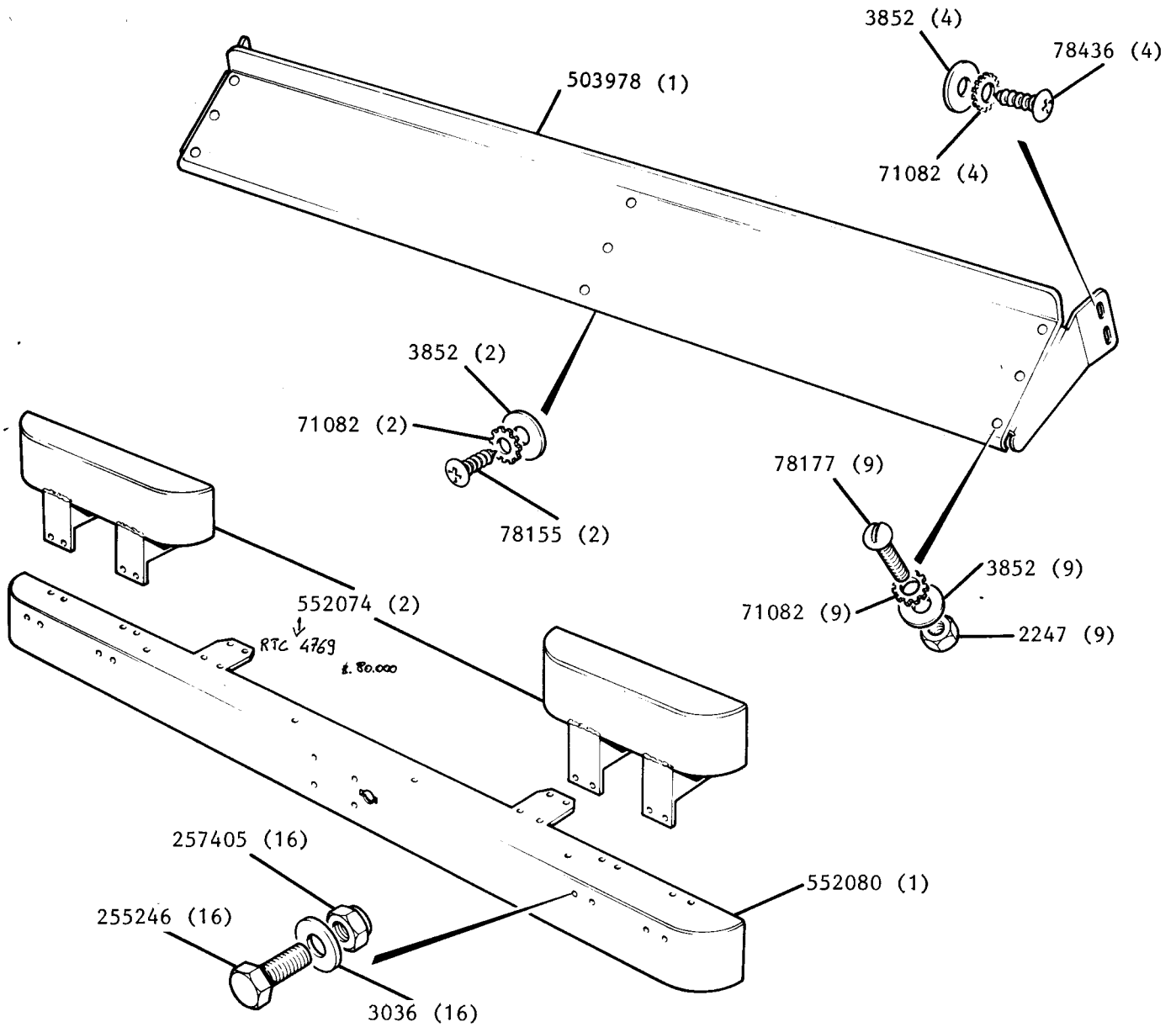

REMARKS

Exterior Sun Visor Kit 503979 (1)

LAMP GUARD, SERIES. IIA AND III.

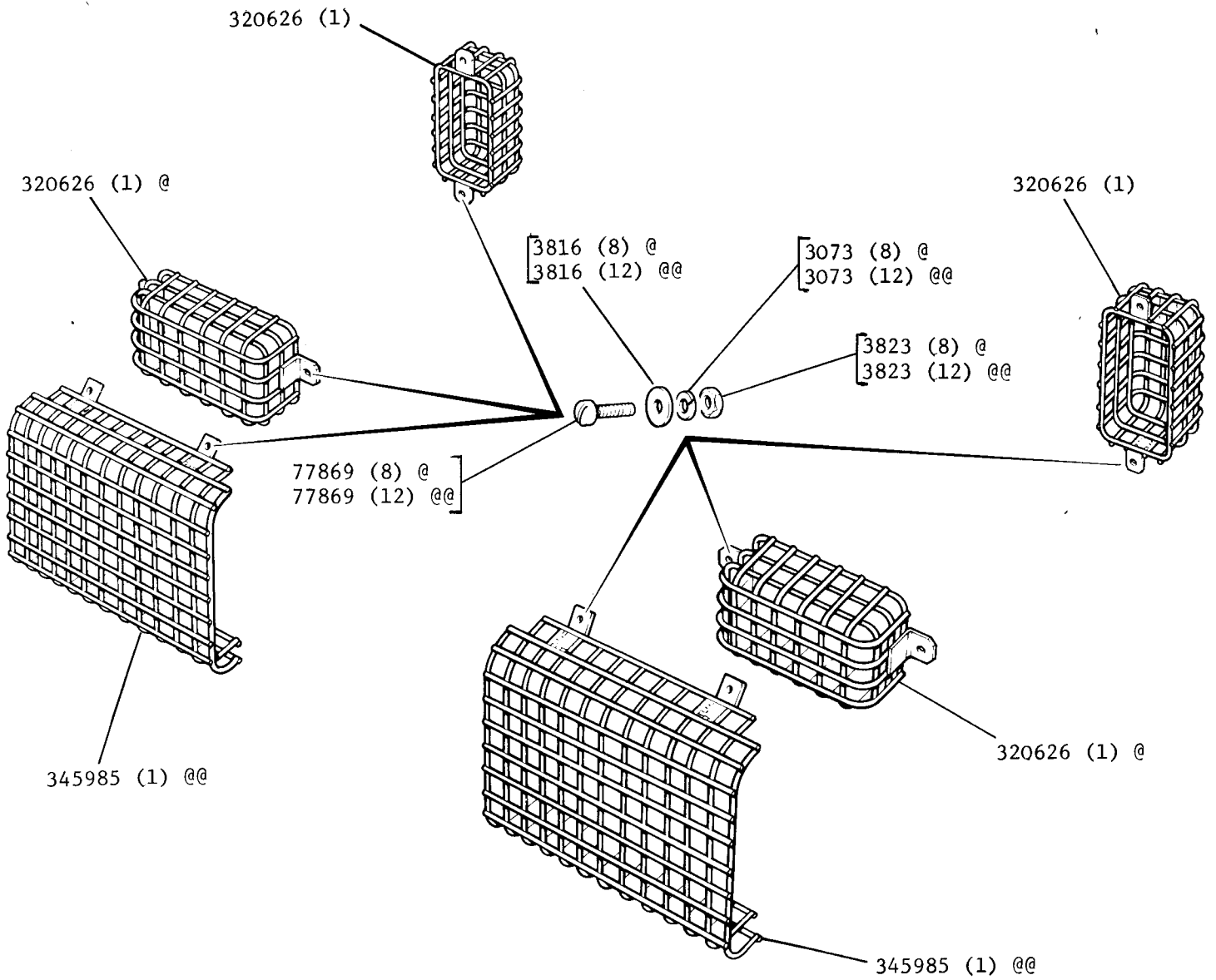

REMARKS

- @ Series IIA up to vehicle suffix F inclusive
- @@ Series IIA from vehicle suffix G onwards and Series III

CHAFF GUARD, SERIES IIA AND III.

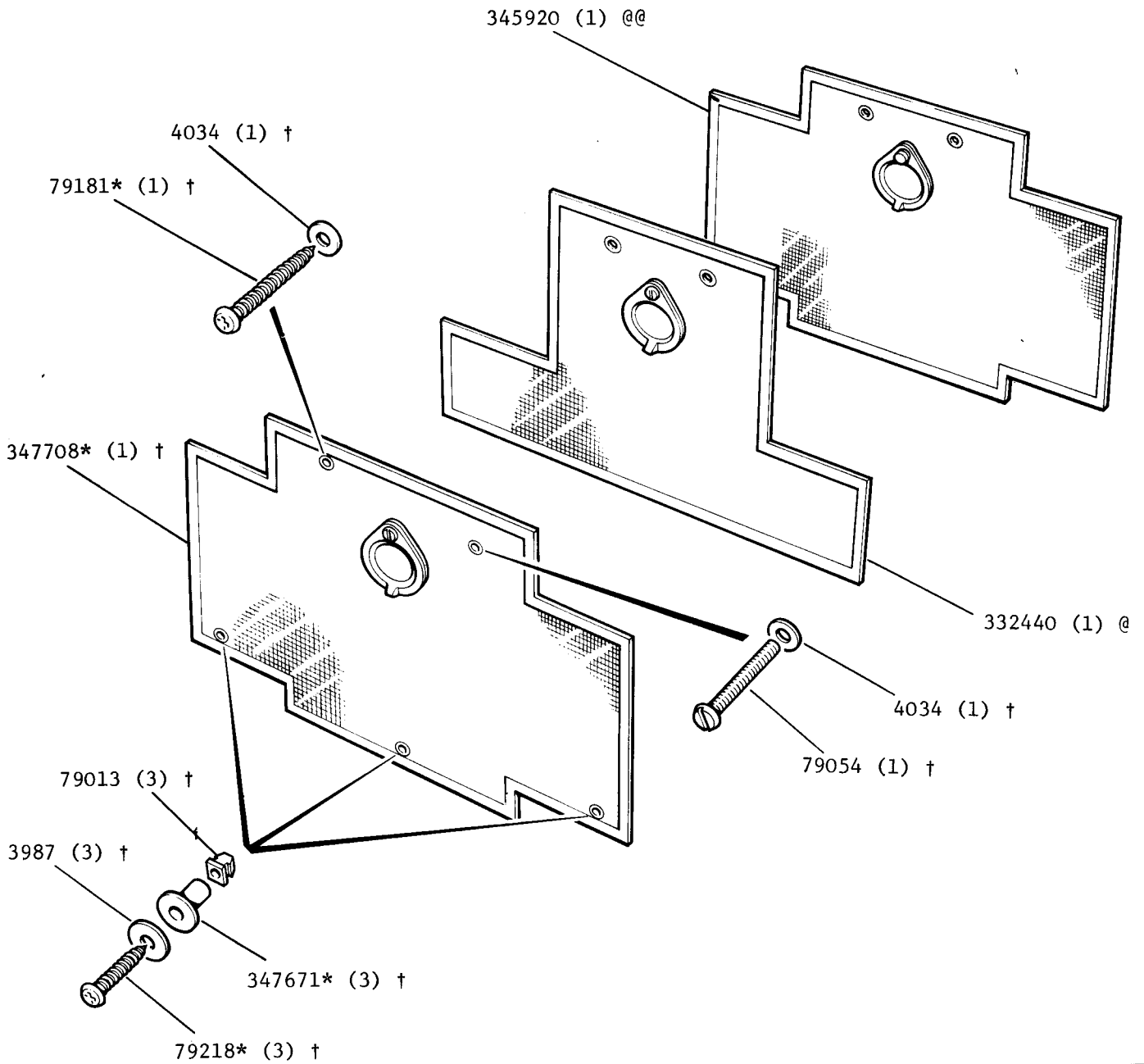

REMARKS

- @ Series IIA up to vehicle suffix F inclusive
- @@ Series IIA from vehicle suffix G onwards
- † Series III

ASHTRAY SERIES IIA AND III

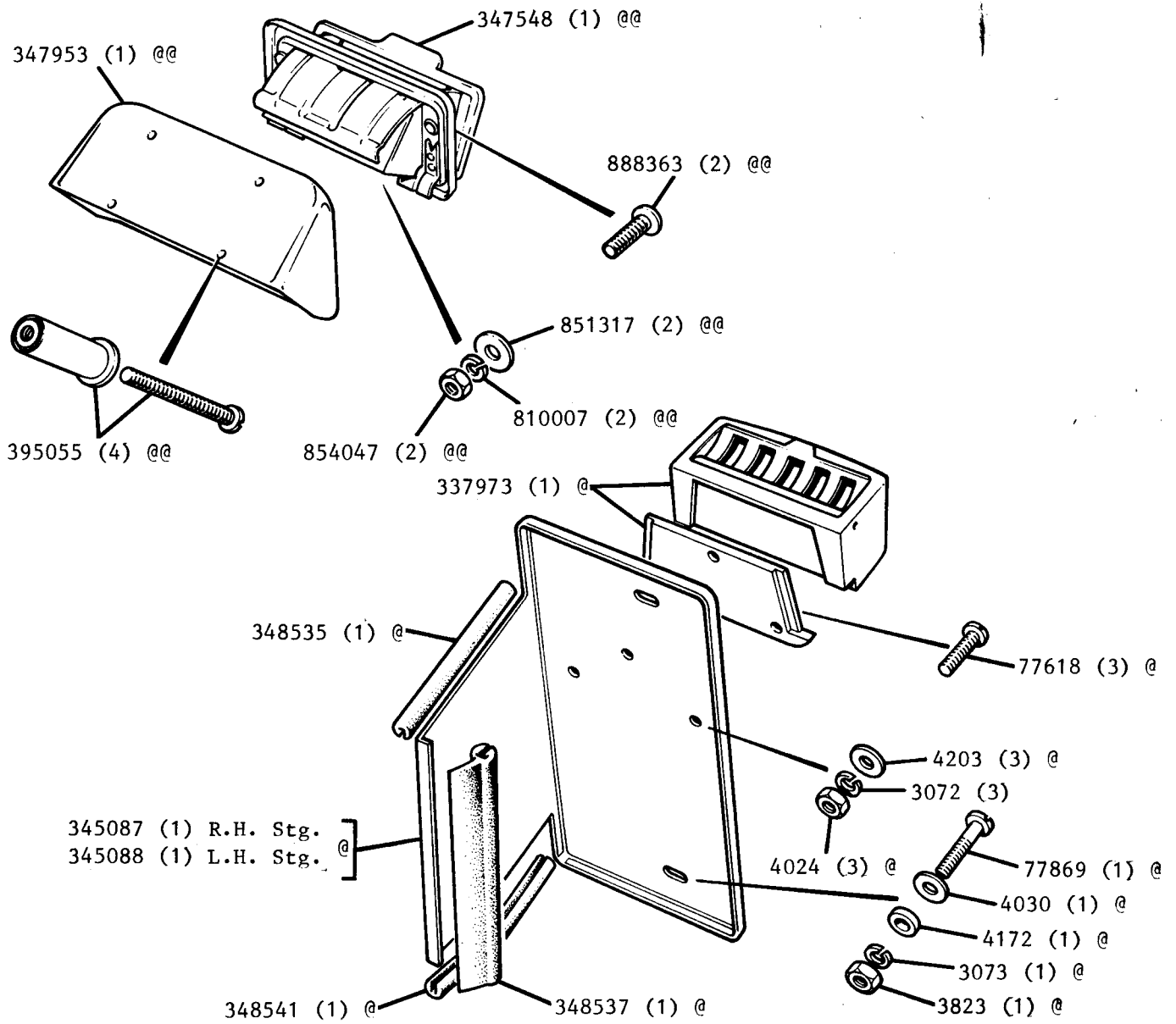

REMARKS

Ashtray Kit 320641 (1) @  
 Ashtray Kit 320831 (1) @@  
 @ Series IIA  
 @@ Series III

WHEELS AND INNER TUBES SERIES IIA AND III

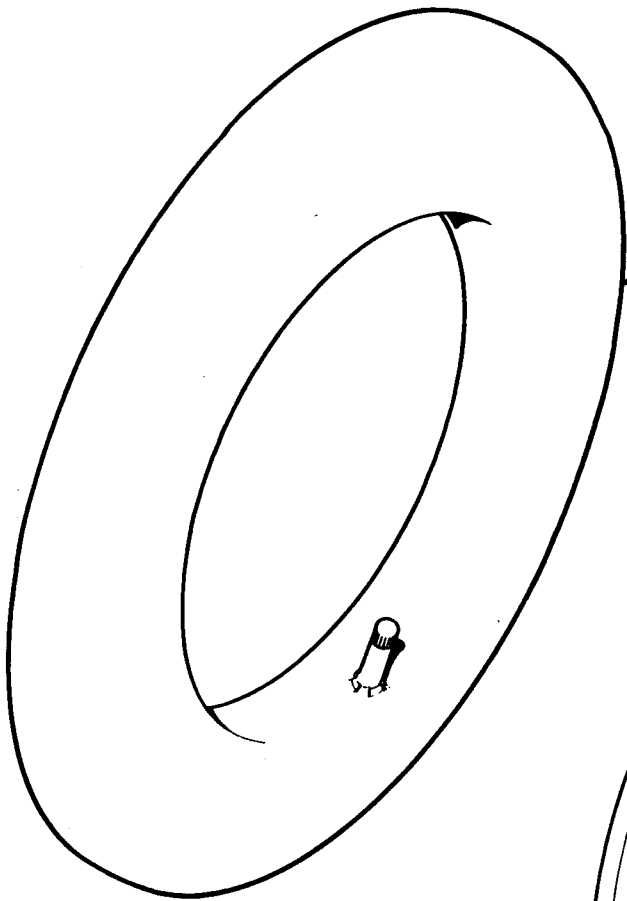

- 232122 (5) 600 x 16 (For tyre 232121)
- 232560 (5) 650 x 16 (For tyre 232559 and 542865)
- 233042 (5) 700 x 16 (For tyre 242861 and 248806)
- 270324 (5) 750 x 16 (For tyre 278434 and 545547)
- 511879 (5) 750 x 16 (For tyre 511878)
- 552232 (5) 750 x 16 (For tyre 552231)
- 526506 (5) 900 x 16 (For tyre 545822)
- 264644 (5) 820 x 15 (For tyre 264643)
- 542864 (5) 900 x 15 (For tyre 542863)

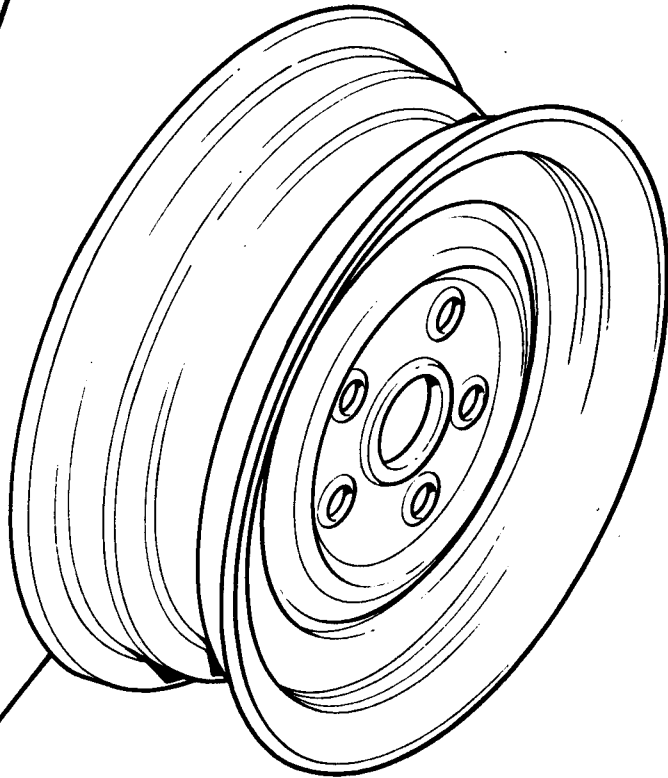

- 526753 (5) All models fitted with 820/900 x 15 Sand tyres
- 272309 (5) 88 in. models fitted with 750 x 16 tyres

REMARKS



TYRES SERIES IIA AND III

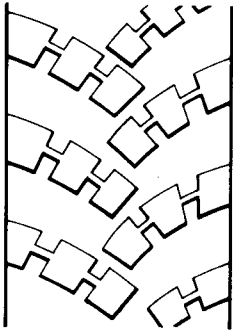

DUNLOP T29A  
232559 (5)  
650 x 16  
DUNLOP T29A  
242861 (5)  
700 x 16  
DUNLOP T29A  
270323 (5)  
750 x 16

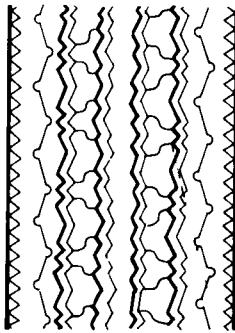

DUNLOP  
"GOLD SEAL"  
502526 (5)  
750 x 16

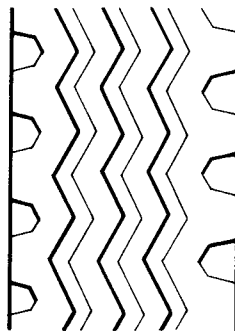

MICHELIN "XY"  
511878 (5)  
750 x 16

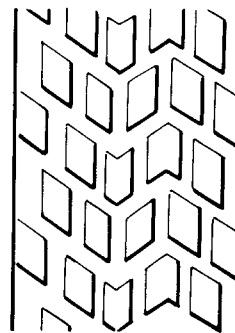

MICHELIN "X"  
SAHARA TYRE  
552231 (5)  
750 x 16

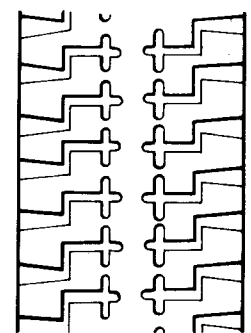

DUNLOP BLOCK TREAD  
542863 (5)  
900 x 15

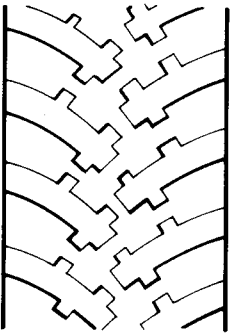

DUNLOP T28  
232121 (5)  
600 x 16

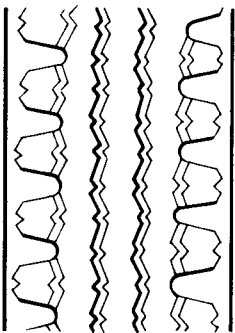

MICHELIN "XS"  
AVON T.M  
DUNLOP R.K.3  
278434 (5)  
750 x 16  
AVON 8 P.R.  
"RANGER"  
545547 (5)  
750x 16

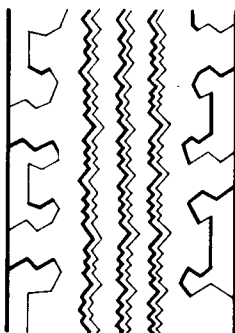

DUNLOP R.K.3  
542865 (5)  
650 x 16  
DUNLOP R.K.3  
AVON T.M  
248806 (5)  
700 x 16

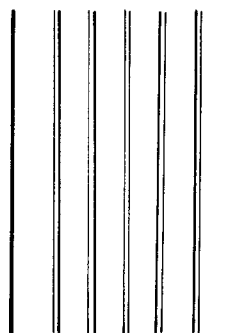

DUNLOP SAND TYRE  
264643 (5)  
820 x 15

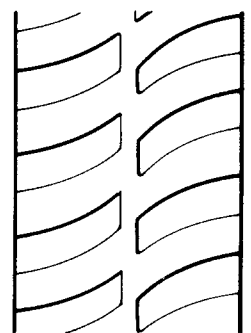

DUNLOP T.24  
545822 (5)  
900 x 16

REMARKS

MUD FLAPS, SERIES IIA AND III

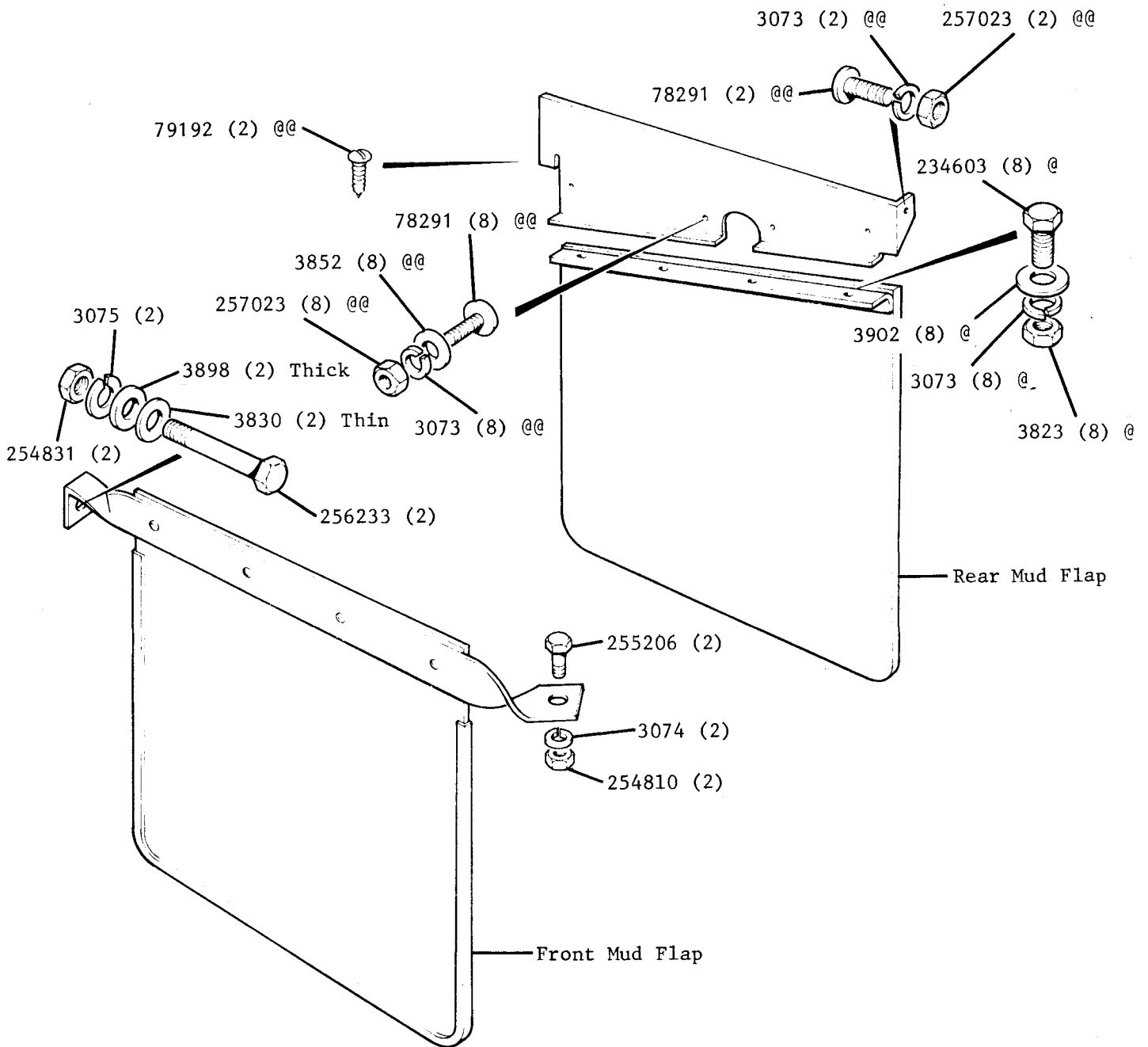

REMARKS

Front Mud Flap Kit 320601 (1)

Rear Mud Flap Kit 320590 (1) @

Rear Mud Flap Kit 607944 (1) @@

@ Series IIA 88" and 109", Series III 88"

@@ Series III 109"

FRONT LIFTING AND TOWING RING ASSEMBLY AND TOWING HOOK SERIES 11A AND 111

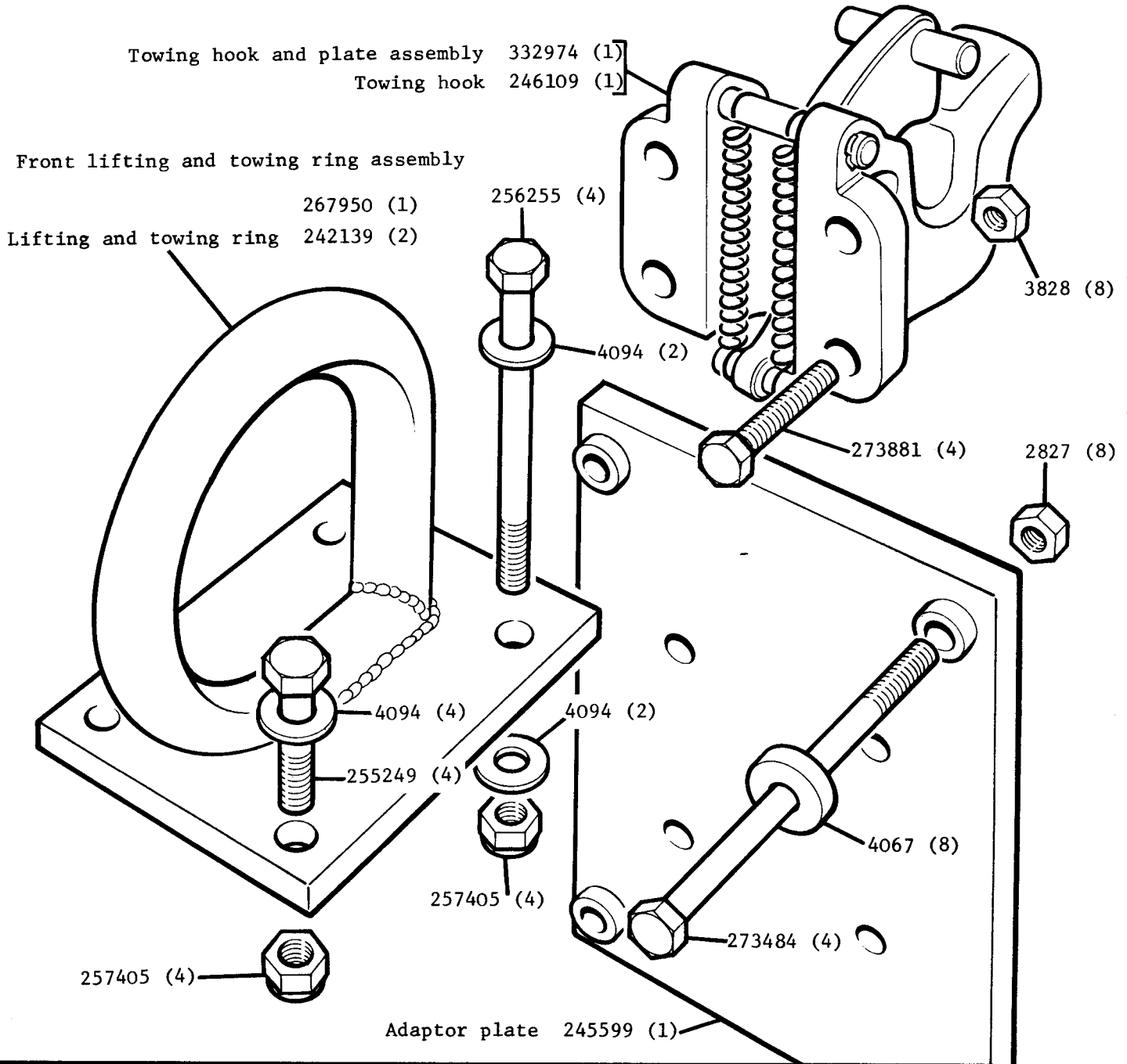

REMARKS

Towing hook not applicable to 109in Station Wagon and cannot be used in conjunction with rear power take-off

TOWING BRACKET ASSEMBLY AND REAR TOWING PLATE SERIES 11A AND 111

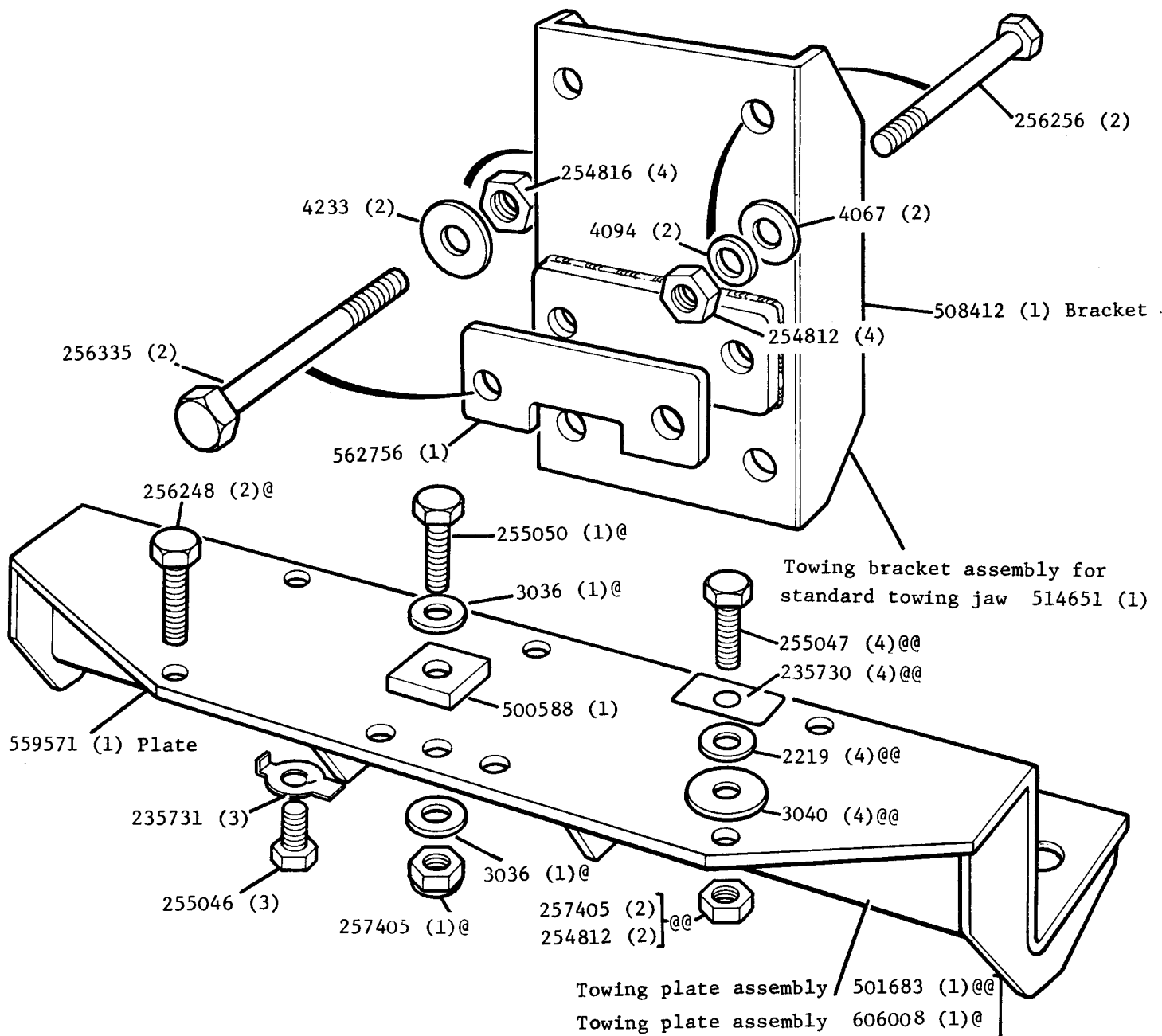

REMARKS

@ 109in long 2.6

@@ 109in long 2¼ and 88in

Towing bracket assembly, fitted as standard to all export models except Swiss vehicles and all home vehicles in conjunction with a trailer

Cannot be used in conjunction with rear towing plates 501683 and 606008

Rear towing plate must be used in conjunction with rear power take-off.

Cannot be used in conjunction with a rear step

TOWING JAW (STANDARD) AND TOWING. PINTLE (HEAVY DUTY) SERIES 11A AND 111

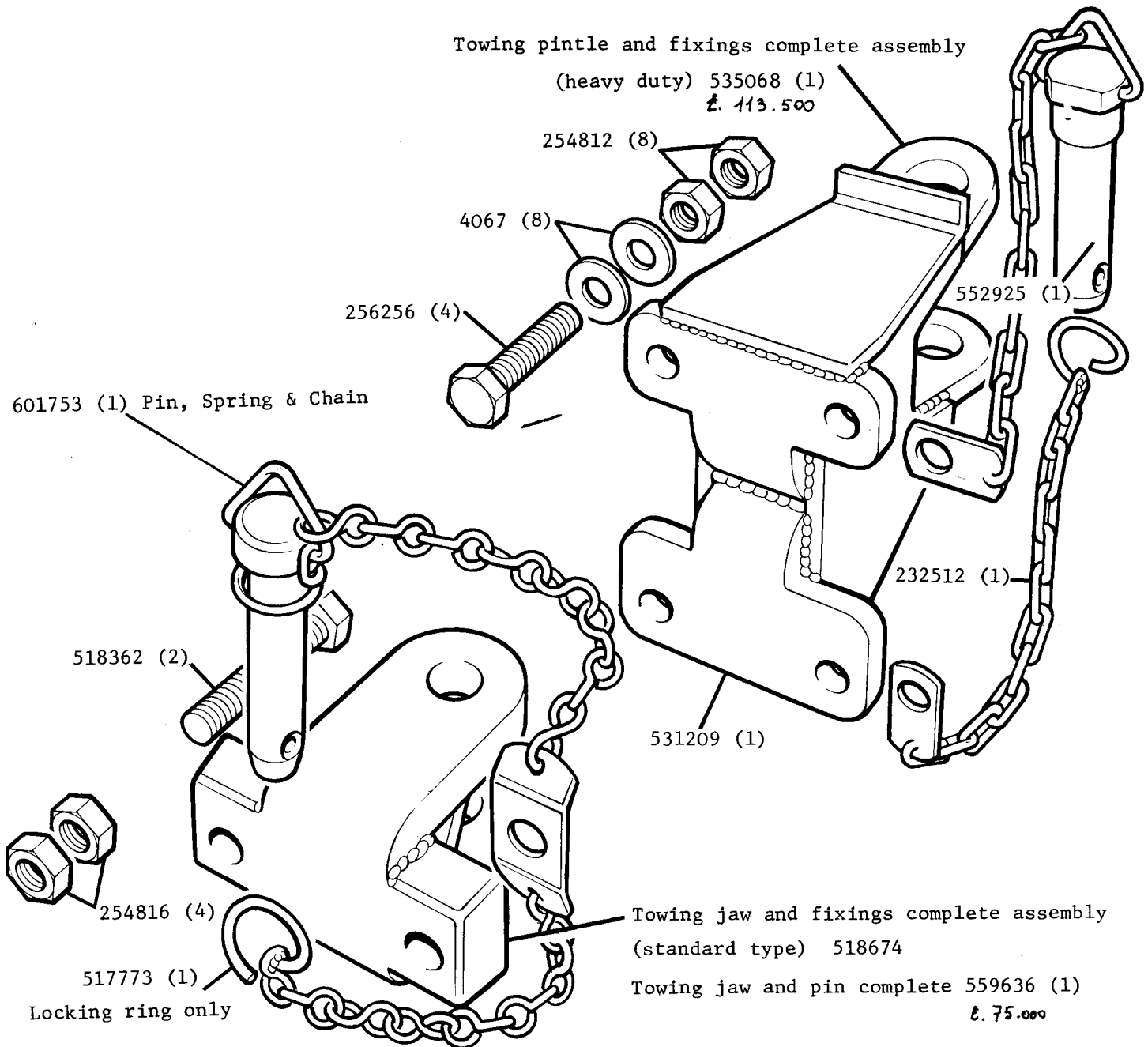

REMARKS

Towing jaw 518674 fitted as standard to all export models except Swiss Vehicles  
Towing jaw and pintle cannot be used in conjunction with rear power take-off